

I CLASSICI

I CLASSICI



OLIVIA

E allora baciami
baciami ancora...





Ricordati vai piano
sentimento confuso
amami ora e ancora







Credevo di cambiare il mondo
e invece sei arrivata tu
tu che scegli me
che cosa voglio di più









HEREND

Con questo vento così caldo
riparo tutti i miei perché
...ah dolce amore ho nel cuore una cometa
ma non aspettare me



Luna che nasce nei tuoi occhi nei tuoi fianchi
che nasce in me







Ah! è un gran dolore
non c'è più rispetto non ho più il contatto





Se solo non amassi
ancora te...





ELIZABETH

É un gioco di parole
in una storia finita
dentro me







Vorrei riuscire ad innamorarti ancora
se tu riuscissi ancora ad innamorare me

















EPOQUE





Sarebbe tutta un'altra storia
sarebbe innamorarsi ancora









BELL





Voglio amare di più
voglio imparare ad essere libera













LAMP









graphic design
Fima Carlo Frattini
photo
davide lovatti

press
grafiche vecchi s.r.l

fima | CARLO FRATTINI®
F U S I O N E S P A

© Fima Carlo Frattini S.p.A.
tutti i diritti riservati / All rights reserved

printed in Italy 04-2015

I CLASSICI F6020



Fima Carlo Frattini S.p.A.
28010 - Briga Novarese (NO)
Via Borgomanero, 105
tel. +39 0322 9549 (r.a.)
fax. +39 0322 956149
e-mail: info@fimacl.com
www.fimacl.com

fima | CARLO FRATTINI®
r u b i n e t t e r i e

FIMANEWS

2021

03

DAVIDE VERCELLI DESIGN

IN o OUT



STILL

DAVIDE VERCELLI DESIGN

UNA NUOVA
DIMENSIONE DI
BENESSERE

A NEW DIMENSION OF WELL-BEING

SWITCH

DAVIDE VERCELLI DESIGN

WWW.FIMACF.COM

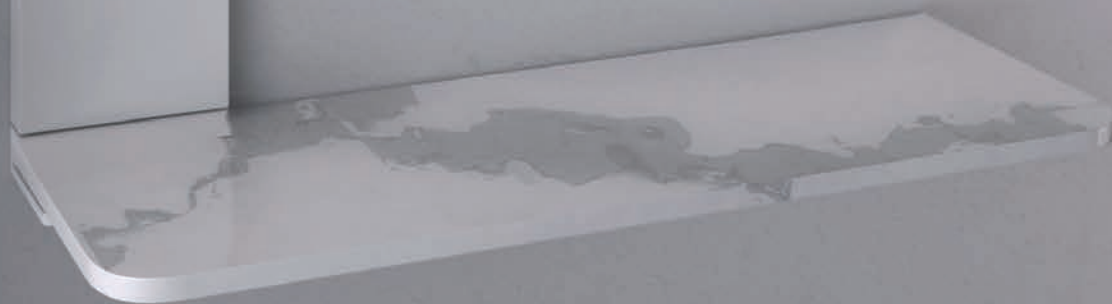

SWITCH

DAVIDE VERCELLI DESIGN

UN SOLO PULSANTE, GRANDI FUNZIONALITÀ

ONE BUTTON, GREAT FEATURES

SWITCH rappresenta un sistema per la doccia ampio e completo, nato dalla costante tensione di migliorare l'esperienza delle azioni quotidiane attraverso gli oggetti, dalla necessità di un uso responsabile di risorse e materiali e dal ruolo centrale della personalizzazione.

Già a partire dal nome, SWITCH racconta uno dei suoi principali plus che lo rende unico nel settore dal punto di vista funzionale e di design: quello di "azionare" con la semplice pressione di un tasto a sfioro rotondo i flussi di acqua in corrispondenza dell'uscita stessa.

Questo innovativo sistema è declinato in tre versioni: a incasso, a mensola e a colonna, così da offrire all'utente finale la possibilità di scelta tra un sistema all in one, facilmente installabile e adatto anche agli interventi di ristrutturazione o un sistema, a incasso, completamente personalizzabile sulla base delle proprie esigenze estetiche e di spazio. La versione a incasso è caratterizzata da una serie di singoli elementi, ciascuno con funzioni differenti, che l'utente può disporre liberamente nello spazio, così da poter azionare i flussi di acqua in corrispondenza della rispettiva uscita.

Al contrario dei sistemi esistenti - in cui solo dalla posizione di regolazione della temperatura e del flusso è possibile azionare le varie utenze attraverso i deviatori - Switch fa corrispondere al tasto premuto la relativa uscita. È quindi possibile costruire il proprio sistema con la massima libertà compositiva e spaziale scegliendo tra diversi elementi, alimentabili indipendentemente o contemporaneamente, ciascuno con una specifica funzione: doccia, bocca a parete, getto laterale, tubo Kneipp e pulsante on/off.

SWITCH represents a wide and complete shower system, resulting from the constant striving to enhance the experience of daily activities through objects, from the need for a responsible way to use resources and materials and from the central role of customization.

Starting from the name, SWITCH points out one of its main pluses which makes it unique in the industry due to both its functionality and design: you can indeed turn on the water flows at the outlet itself by simply pushing a round infinity-edge button.

This innovative system is available in three versions: built-in, shelf and shower column. The end consumer has thus the chance to choose between an all-in-one system, easy to install and even suitable for renovations, or a built-in one, completely customizable to suit any aesthetic and space need.

The built-in version is made up of a series of single items, each one with different functions, that the user can arrange freely in the shower space. Unlike the existing systems - in which the different units can be only turned on by the diverters positioned in the control module - SWITCH matches the pressed button to the corresponding outlet. It is thereby possible to create your own shower system with the greatest design freedom by choosing from different items, supplied independently or simultaneously. Each one with a specific function: hand shower, water spout, side jet, Kneipp hand shower and ON/OFF Switch button.

DOCETTA F5925NS

La doccetta richiama con la sua distintiva texture godronata gli altri elementi della serie Switch. Il design ergonomico permette una presa agevole e il suo utilizzo diventa più naturale grazie all'aeratore posto in posizione verticale e al pulsante di comando integrato nella piastra.

HANSHOWER F5925NS

The handshower reminds the other items of Switch line thanks to its distinctive knurled texture. The ergonomic design offers an easy grip and its comfort is enhanced by the vertical jet and by the proximity of the push button.

BOCCA EROGAZIONE F5926NS

La bocca di erogazione è stata specificatamente sviluppata per essere integrata al sistema Switch. Innovativa è la possibilità di dislocare liberamente la bocca di erogazione in fase di installazione. Il pratico pulsante di comando permette un'immediata apertura dell'acqua.

WATER SPOUT F5926NS

The spout has been specially designed to be part of the Switch system. The unit can be installed in the desired position independently from the location of the control module. The handy push button turns on the water instantly.

PULSANTE ON/OFF F5922NS

L'elemento on/off può essere abbinato a qualsiasi punto di erogazione a parete. E' inoltre disponibile un kit di differenti tasti personalizzati e facilmente intercambiabili che permettono una facile identificazione dell'uscita corrispondente: getto laterale, soffione, doccetta, lama d'acqua.

ON/OFF BUTTON F5922NS

A handy push button turns on the water flow at the corresponding wall mounted outlet. A kit of different customized easily interchangeable buttons are available to identify the corresponding outlet: side jet, head shower, hand shower, water blade.



GETTO LATERALE F5923NS

Il getto laterale ad alta efficienza è orientabile e integrato nella piastra di comando per un facile accesso e una fruizione confortevole. Il pulsante è posto in corrispondenza del getto per permetterne una comoda attivazione. Le specifiche performance consentono di attivare contemporaneamente fino a 4 getti

SIDE JET F5923NS

The high-efficiency adjustable side jet, built in the control plate, is easily accessible and comfortable in use. Switch button and side spray are next to each other. Up to 4 jets can work at once offering the utmost comfort.

TUBO KNEIPP F5924NS

Grazie al suo specifico rompigetto e all'abbondante flusso d'acqua, il tubo kneipp regala una piacevole sensazione di benessere ad ogni utilizzo. Il pratico pulsante on/off integrato nella piastra ne permette l'agevole attivazione e la libera installazione all'interno dell'ambiente doccia.

KNEIPP HANDSHOWER F5924NS

Thanks to its particular aerator and its high water flow, the Kneipp hand shower gives a pleasant feeling of well-being at each use. The infinity-edge handy button enables an easy activation as well as a customized installation inside the shower area.





F5925CR + F5922CR + F5924CR

La versione a incasso di Switch consente due modalità installative: **LIBERA** e **LINEARE**. L'installazione libera offre una straordinaria autonomia progettuale, permettendo di distribuire liberamente all'interno dell'ambiente doccia tutti i componenti scelti per formare una composizione custom-made. L'installazione lineare invece è predefinita e facilitata grazie a un apposito binario, da incassare direttamente nel muro, su cui gli elementi vengono già forniti pre-installati.

The Switch built-in version offers two types of installation: **FREE** or **LINEAR**. The free installation gives you an outstanding design autonomy, enabling all the items to be freely arranged within the shower area in a customized way. The linear installation instead is preset and simplified thanks to a special plate, to be built directly into the wall, on which the items are supplied pre-installed.

“La zigrinatura verticale dei profili, crea un contrasto con le superfici lisce dando vita a un design unico e inconfondibile”

SWITCH INCASSO

Nel caso di installazione multipla la rimozione del tappo di arresto laterale permette l'allacciamento in serie di più elementi garantendo performance di erogazioni inalterate.

In case of multiple installation, the removal of the side sealing plug allows the connection in series of more fixtures guaranteeing unchanged performance of water delivery.

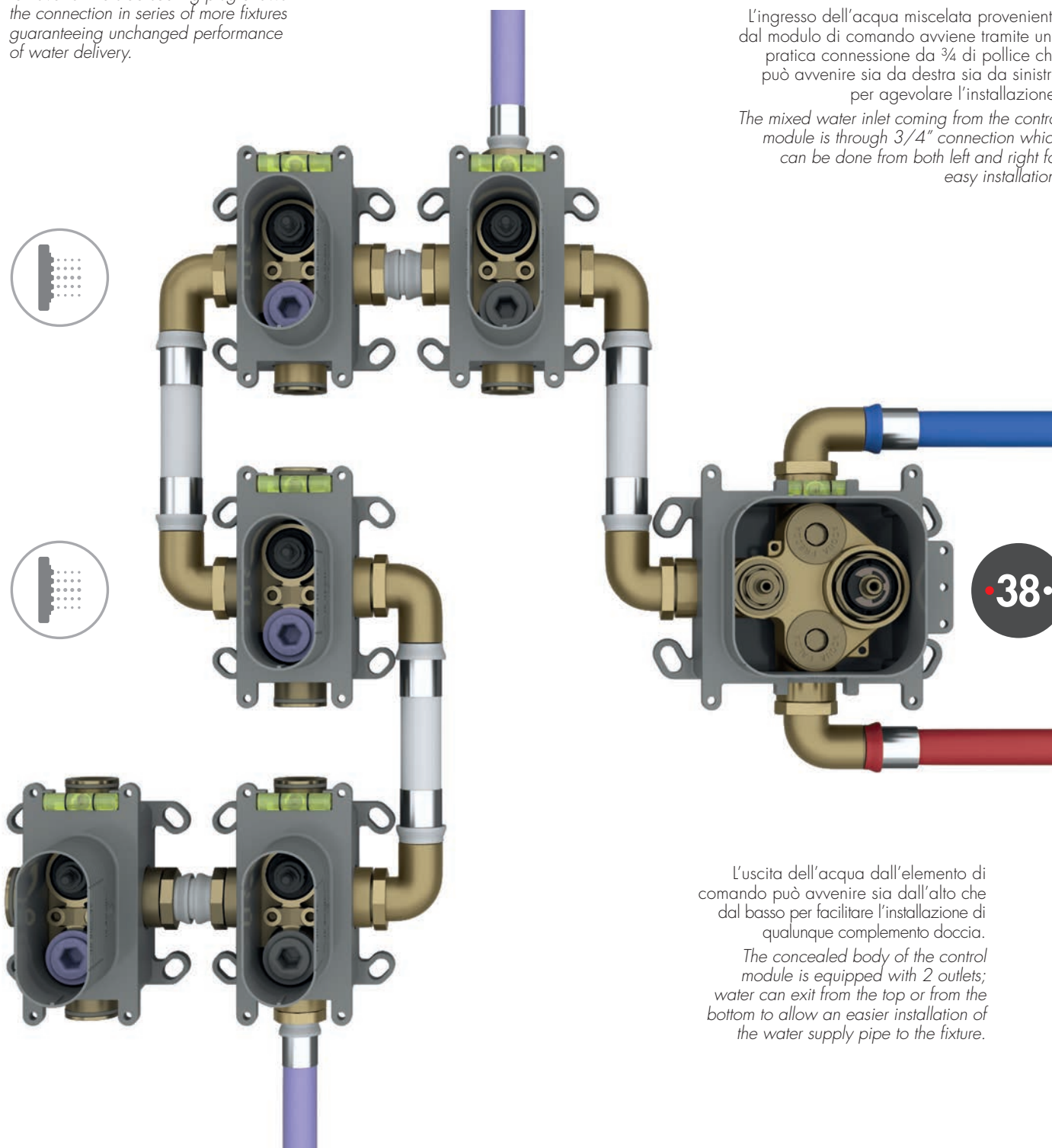
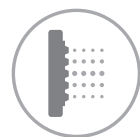

L'ingresso dell'acqua miscelata proveniente dal modulo di comando avviene tramite una pratica connessione da 3/4 di pollice che può avvenire sia da destra sia da sinistra per agevolare l'installazione.

The mixed water inlet coming from the control module is through 3/4" connection which can be done from both left and right for easy installation.

L'uscita dell'acqua dall'elemento di comando può avvenire sia dall'alto che dal basso per facilitare l'installazione di qualunque complemento doccia.

The concealed body of the control module is equipped with 2 outlets; water can exit from the top or from the bottom to allow an easier installation of the water supply pipe to the fixture.



Il caratteristico guscio protettivo garantisce facilità di installazione, protezione contro le infiltrazioni e isolamento acustico oltre a tutte le altre peculiarità comuni a tutta la serie FIMABOXES.

The protective casing allows an easy installation, protection against water infiltration and acoustic isolation in addition to all the other features we find in all FIMABOXES.

38

SWITCH INCASSO





F5923CR

Al centro dell'impianto, il blocco che regola temperatura e portata, anch'esso posizionabile liberamente nello spazio, comanda tutto il sistema e garantisce praticità di utilizzo e comfort. All'attivazione di ciascuna uscita, viene sempre erogato il quantitativo di acqua preimpostato all'ultimo utilizzo, che può andare da un minimo a un massimo di portata regolabile attraverso la rispettiva manopola di comando.

Per rendere le modalità di comando più agevoli, così da semplificare "l'esperienza doccia", il design delle due manopole di regolazione temperatura e portata è generoso e con un rilievo centrale raccordato alla base che ne permette una semplice fruizione. La superficie laterale è lavorata con una godronatura molto ampia che favorisce una facile presa laterale. Particolare attenzione è rivolta anche all'estetica e all'eco-sostenibilità: da un lato, grazie al contenimento dei volumi dei corpi a incasso, le dimensioni esterne e gli ingombri sono più discreti; dall'altro la naturale posizione verticale delle manopole è studiata in modo da "educare" a un uso più responsabile dell'acqua, invitando a utilizzare una portata che soddisfi le esigenze quotidiane e al contempo garantisca risparmio idrico.

At the centre of the system the control module adjusts the temperature and the flow rate. The module can be placed at random inside the shower enclosure and controls all fixtures, guaranteeing high functionality and comfort.

Each fixture connected to the module delivers water based upon the set flow rate that ranges from a minimum to a maximum and can be changed by means of a very practical knob. Both temperature and flow rate knobs are provided with a side knurled pattern to allow a better grip and a more comfortable use.

Special attention has been given to the aesthetics and to the sustainability, so that the small size of the concealed bodies reduces the dimensions of the external parts creating a minimal look and the vertical position of the lever of the flow rate knob wants to help the consumer to be water efficient, in fact in that position the flow rate is perfect to enjoy a shower guaranteeing water saving.

UN GRANDE CUORE CHE COMANDA OGNI COSA

A BIG HEART CONTROLLING EVERYTHING



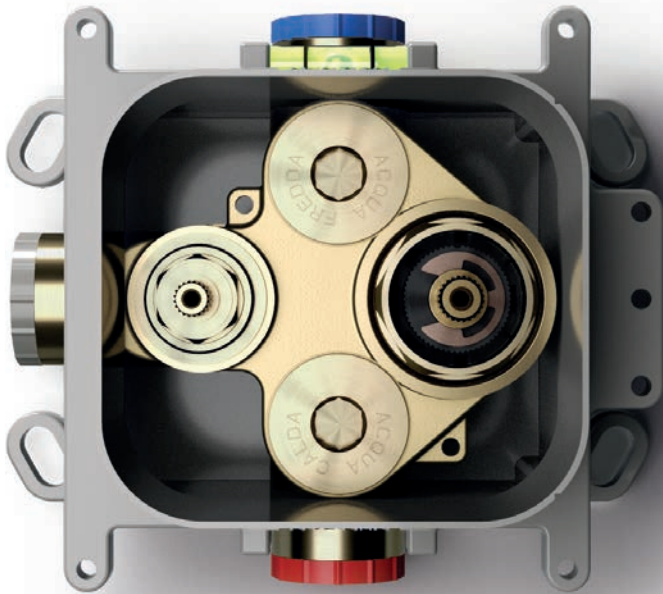

F4010

Il corpo a incasso del blocco di comando cela al suo interno una serie di innovazioni tecnologiche nate dall'approccio di continua ricerca e innovazione, condotto negli anni, nello sviluppo delle serie FIMABOXES. Gli ingressi dell'acqua calda e fredda da 3/4 di pollice, uniti agli elementi di controllo della temperatura e del flusso ad alta portata, garantiscono prestazioni costanti anche nel caso di utilizzo contemporaneo di più elementi di erogazione. I filtri e le valvole di non ritorno sono facilmente ispezionabili permettendo un'agevole manutenzione che garantisce inalterate performance nel tempo. Le scocche protettive e il caratteristico guscio, che assicura isolamento acustico e da infiltrazioni, ne consentono una facile installazione. Icone e colori appositamente studiati agevolano le connessioni di acqua calda e fredda e in caso di problemi, un innovativo sistema espressamente progettato, permette il funzionamento del blocco di comando anche in caso di installazione con acque invertite.

The concealed body of the control module presents several technological innovations, as a result of the ongoing research of Fima R&D Department over the years.

The 3/4" water inlets together with the temperature and the high flow rate knobs guarantee great performance delivering constant water even to multiple fixtures. Filters and non return valves can be easily inspected allowing fast maintenance to ensure a good performance throughout the years. The protective covers and the distinctive casing guarantee water and acoustic isolation and an easy installation. Icons and colours indicate hot and cold water inlets. In case of mistakes, an innovative system lets the control module work even with reversed water connection.



F4020

Un corpo a incasso studiato per il massimo comfort.

L'ingresso dell'acqua miscelata proveniente dal modulo di comando avviene tramite una pratica connessione da 1/2 pollice che può avvenire sia da destra sia da sinistra per agevolare l'installazione. Nel caso di installazione multipla la rimozione del tappo di arresto laterale permette l'allacciamento in serie di più elementi garantendo performance di erogazioni inalterate.

Il caratteristico guscio protettivo garantisce facilità di installazione, protezione contro le infiltrazioni e isolamento acustico oltre a tutte le altre peculiarità comuni a tutta la serie FIMABOXES.

L'uscita dell'acqua può essere configurata in modo frontale, superiore o inferiore in base alla disposizione scelta in fase di installazione. Le cover e i tappi protettivi garantiscono l'integrità del corpo fino all'installazione delle parti esterne.

A built-in body designed for the utmost comfort.

The mixed water inlet coming from the control module can be connected from the right or the left by means of a practical 1/2" entry. In case of multiple installation, the removal of the side sealing plug allows the connection in series of more fixtures guaranteeing unchanged performance of water delivery.

The protective casing allows an easy installation, protection against water infiltration and acoustic isolation in addition to all the other features we find in all FIMABOXES.

The water outlets can be upper, lower and/or frontal based upon the selected fixtures. The protective covers and the plugs guarantee the integrity of the concealed body before the installation of the external parts.

L'INNOVAZIONE DEL SISTEMA DOCCIA IN UNO SWITCH

THE INNOVATION OF THE SHOWER SYSTEM IN A SWITCH



SWITCH MENSOLA

Nell'immagine, SWITCH MENSOLA di FIMA Carlo Frattini proposto nella finitura nero opaco con vetro satinato scuro e doccetta. La tecnologia SWITCH è racchiusa all'interno di un corpo erogatore a due uscite che ha una doppia funzionalità: contenere i comandi nella parte frontale e fungere da pratica superficie di appoggio.

In the picture: FIMA's SWITCH MENSOLA in matt black finish with satined anthracite glass and handshower. SWITCH technology is built in a body with 2 outlets and 2 functions, on front of the body the buttons and knobs to turn on water and adjust flow and temperature and on the top a useful shelf.



La versione MENSOLA amplia le possibilità di installazione della serie e si contraddistingue per il fatto che tutto il sistema Switch è racchiuso in un corpo erogatore ridotto e dagli ingombri minimi.

I comandi di regolazione di temperatura e flusso sono stati integrati insieme ai due pulsanti di attivazione dell'uscita soffione e del doccino, massimizzando la praticità di utilizzo e donando uno stile unico e inconfondibile al sistema doccia.

Il doccino, elemento iconico della serie, richiama con la sua distintiva texture godronata gli elementi di comando. e Il design ergonomico permette una presa agevole e un utilizzo più naturale grazie all'aeratore posto in posizione verticale.

La pratica versione a MENSOLA è disponibile in finitura cromo, nickel spazzolato, nero e bianco opaco, viene abbinata a un ripiano in vetro satinato, di colore antracite nella versione nero opaco e di colore grigio chiaro in tutte le altre versioni, per uno stile distintivo a ogni ambiente doccia.

The MENSOLA (SHELF) version of the Switch series increases the possibilities for installations. For simplification the entire Switch system has been concentrated in a small compact body.

The temperature and waterflow controls have been added to the two on/off buttons of the shower head and handshower to be more functional and to conceive an unique design.

The knurled pattern of the iconic handshower recalls the design of the control module knobs and the ergonomic grip with the vertical aerator enable a natural shower experience.

The practical SHELF is available in the following stylish finishes - chrome, matt black, matt white and brushed nickel and is matched with a satined glass shelf, that is anthracite colour for the matt black version and light grey for all the other finishes, an additional distinctive touch to the shower.



SWITCH COLONNA



UN SISTEMA ALL-IN-ONE ALLA PORTATA DI TUTTI

AN ALL IN ONE SYSTEM

La versione a COLONNA, è un sistema all-in-one che deriva direttamente dalla versione mensola. E' particolarmente indicata per chi desidera rinnovare lo stile del proprio ambiente bagno senza dover affrontare importanti lavori di ristrutturazione, in quanto permette l'installazione sulle tradizionali uscite di acqua calda e fredda con interasse 150 mm. Il sistema Switch abbinato alla nuova colonna doccia è in grado di garantire benessere, funzionalità e un look inconfondibile.

A follow through from the SHELF version is the SHOWER COLUMN version of the SWITCH, which is the perfect answer for the client who wants to update the style of their bathroom with having to undertake renovation work. Designed for installation on traditional hot and cold water outlets with a 150mm wheelbase the Switch combined with the new shower column guarantees style, function and wellbeing.



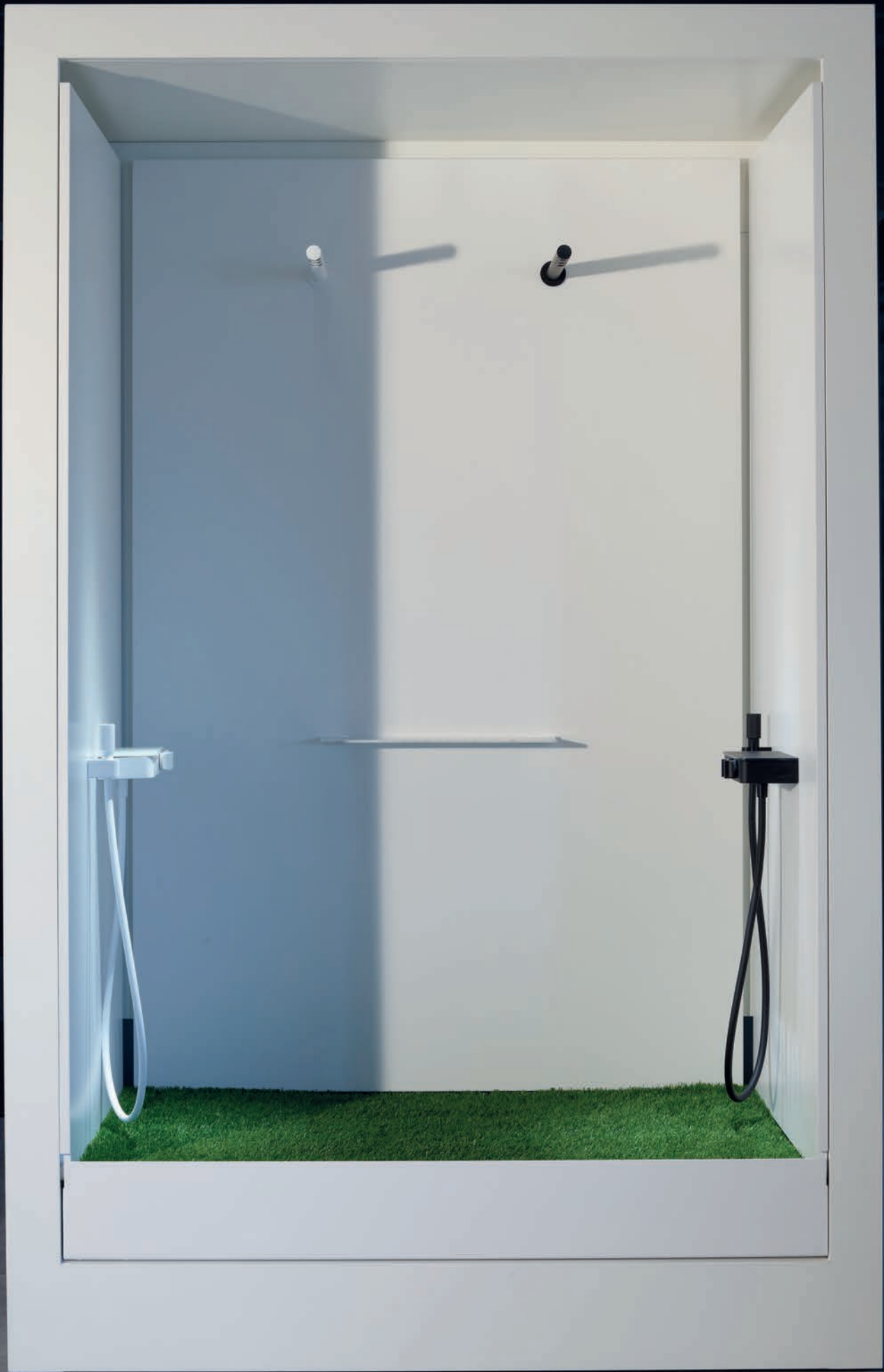

STILL

DAVIDE VERCELLI DESIGN

UN PROGETTO AMBIZIOSO CHE APRE UNA NUOVA DIMENSIONE DI BENESSERE

AN AMBITIOUS PROJECT THAT OPENS A
NEW DIMENSION OF WELL BEING

Ricerca estetica, rigore formale e distintive performance: nasce STILL di Fima Carlo Frattini, un progetto ambizioso che apre a una nuova dimensione di benessere. Il design minimale e all'avanguardia di questo nuovo soffione è l'espressione di un concept semplice e lineare capace di trasformare l'ambiente bagno in un luogo di relax: un unico elemento cilindrico al cui interno sono installati 3 aeratori orientabili singolarmente a piacere.

Le sue linee pulite ed essenziali esaltano il naturale movimento dell'acqua e l'approfondito studio ergonomico consente di vivere un'esperienza doccia memorabile e avvolgente garantendo un ridotto consumo idrico, di soli 8 litri di acqua al minuto.

Le performance di erogazione unite alla pulizia estetica della silhouette offrono un'ampia possibilità di personalizzazione grazie all'abbinamento più soffioni per creare composizioni doccia dal forte impatto estetico. Tutti i corpi FimaBoxes consentono di alimentare

con una sola uscita fino a due soffioni contemporaneamente, mentre quelli a incasso ad alta portata permettono l'utilizzo di più soffioni contemporaneamente dando vita a scenografiche configurazioni. Still rappresenta la soluzione ideale per riscoprire e vivere i benefici dell'acqua incontrando al contempo le esigenze stilistiche dell'abitare contemporaneo.

La palette di finiture oltre al classico cromo o nickel spazzolato si declina in tutte le finiture galvaniche quali il cromo nero, il cromo nero spazzolato, l'oro e l'oro spazzolato. Non mancano poi le finiture nero opaco e bianco opaco che grazie all'effetto soft touch, donano un carattere estremamente contemporaneo, perfetto per giocare con abbinamenti total look o in contrasto.

Il nuovo soffione Still si inserisce perfettamente all'interno della gamma di Fima Carlo Frattini, un progetto wellness integrato in grado di garantire funzionalità, benessere e un look inconfondibile.

STILL



F5912BS



F5912NS

Aesthetic research, formal rigor and distinctive performance: Still is born, an ambitious project that opens up to a new dimension of well-being. The minimal and avant-garde design of this new shower head is the expression of a simple and linear concept capable of transforming the bathroom in a place of relaxation: a single cylindrical element inside which 3 individually adjustable aerators are installed. Its clean and essential lines enhance the natural movement of water and the in-depth ergonomic study allows you to experience a memorable and enveloping shower experience, guaranteeing a reduced water consumption of only 8 liters of water per minute.

The delivery performance combined with the aesthetic cleanliness of the silhouette offer a wide range of customization possibilities thanks to the combination of multiple shower heads to create shower compositions with a strong aesthetic impact. All FimaBoxes bodies allow you to feed up to two shower heads simultaneously with a single outlet, while the high-flow recessed ones allow the use of multiple shower heads at the same time, giving rise to spectacular configurations. Still represents the ideal solution to rediscover and experience the benefits of water while meeting the stylistic needs of contemporary living. In addition to the classic chrome or brushed nickel, the palette of finishes is available in all the galvanic finishes such as black chrome, brushed black chrome, gold and brushed gold. There are also matt black and matt white finishes which, thanks to the soft touch effect, give an extremely contemporary character, perfect for playing with total look or contrasting combinations.

“Il suo design è l'espressione di un concetto semplice e lineare: un singolo elemento cilindrico al cui interno sono installati 3 aeratori orientabili”

Its design is the expression of a simple concept: a single cylindrical element where 3 swiveling aerators are installed





DAVIDE VERCELLI DESIGN

RIFLETTORI PUNTATI SULLA PERSONALIZZAZIONE DEL BENESSERE

SPOTLIGHT ON THE CUSTOMIZATION OF WELLNESS

Un notevole impatto estetico e un design originale e innovativo sono la cifra distintiva del nuovo soffione O3, che gioca sulla possibilità di comporre l'ambiente wellness in modo personale per costruire la propria esperienza benessere grazie a tre diverse erogazioni.

Frutto di un ricercato e approfondito processo creativo strettamente legato allo sviluppo di prodotti incentrati sul design volti a migliorare sensibilmente l'esperienza doccia, a garantire un uso responsabile delle risorse e a esprimere le attuali tendenze, O3 si contraddistingue per il suo stile estremamente riconoscibile. A livello formale le scelte progettuali, votate alla funzionalità e al design, vedono l'abbinamento dinamico di due elementi cardine del soffione: un corpo cilindrico che eroga l'acqua e un particolare elemento di supporto e distribuzione con forma a "L". Questo elemento, a cui il corpo principale cilindrico del soffione è collegato a parete o a soffitto, ha la duplice funzione di portare l'acqua ai getti e di orientare il gruppo di erogazione, attraverso un innovativo sistema di snodo, in base alle esigenze del proprio rituale doccia. Segno peculiare è il suo sottile profilo, realizzato con tecnologie all'avanguardia, che con soli 6 mm di spessore rende l'erogazione dell'acqua quasi un gioco di magia.

A remarkable aesthetic impact and an original and innovative design are the distinctive features of the new O3 shower head, which plays on the possibility of composing the wellness environment in a personal way to build your own wellness experience thanks to three different dispensing options.

The result of a refined and in-depth creative process closely linked to the development of products focused on design aimed at significantly improving the shower experience, ensuring responsible use of resources and expressing current trends, O3 stands out for its extremely recognizable style. On a formal level, the design choices, devoted to functionality and design, see the dynamic combination of two key elements of the shower head: a cylindrical body that delivers water and a particular support and distribution element with an L shape. This element, to which the main cylindrical body of the shower head is connected to the wall or to the ceiling, has the dual function of bringing water to the jets and orienting the delivery unit, through an innovative joint system, according to the needs of the individual. shower ritual. A peculiar sign is its thin profile, made with cutting-edge technologies, which with only 6 mm thickness makes the water supply almost a magic game.

Il soffione O3 è disponibile in due differenti versioni che permettono di dare una precisa identità estetica all'ambiente bagno: IN e OUT. La prima - più tradizionale e dalla silhouette più compatta e pulita - prevede il posizionamento del cilindro erogatore all'interno dell'elemento a L, in allineamento con la connessione di alimentazione dell'acqua. Questa variante garantisce anche un'installazione lineare rispetto agli elementi di comando della doccia. La seconda, dona una connotazione inedita e originale grazie al posizionamento del cilindro erogatore all'esterno rispetto all'elemento distributore a L, che può essere collocato sia a destra sia a sinistra.

The O3 shower head is available in two different versions that allow you to give a precise aesthetic identity to the bathroom: IN and OUT. The first - more traditional and with a more compact and clean silhouette - involves the positioning of the dispensing cylinder inside the L-shaped element, in alignment with the water supply connection. This variant also guarantees a linear installation with respect to the shower control elements. The second gives a new and original connotation thanks to the positioning of the dispensing cylinder outside the L-shaped distributor element, which can be placed both on the right and on the left.



F5919CR

IN o OUT



F5915CR

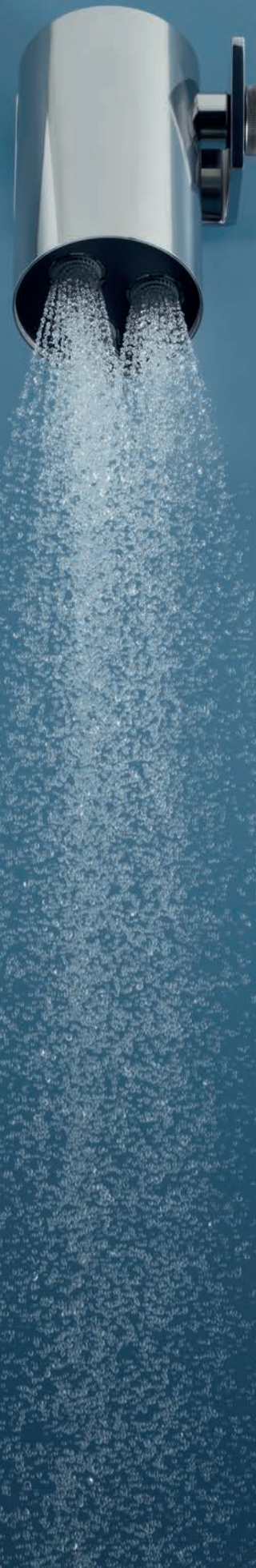



Per rendere l'ambiente bagno una vera oasi di benessere è possibile scegliere tra tre differenti modalità di erogazione: Rain, Laminare e Cascata. I tre innovativi aeratori del getto Rain assicurano un ampio flusso di acqua, morbido e piacevole, garantendo al contempo un consumo idrico di soli 8 litri al minuto. Possono essere orientati singolarmente per modulare a piacimento il flusso così da vivere un autentico momento rilassante. Grazie allo specifico rompigitto e all'abbondante flusso d'acqua, il getto Laminare di O3 trasforma la doccia in una vera coccola sensoriale. L'unicità del getto sta nella trasparenza e nella ridotta velocità del flusso che, a contatto con il corpo, regala una gradevole sensazione rigenerante. Il getto a cascata è studiato per offrire un massaggio energizzante e vigoroso. Il suo flusso veloce e deciso avvolge completamente il corpo e garantisce un perfetto relax anche con basse portate.

Il soffione O3 si declina in un ampio portfolio di finiture, che lo rendono ideale per valorizzare ogni ambiente bagno.

To make the bathroom a true oasis of well-being, you can choose between three different delivery modes: Rain, Laminar and Cascade. The three innovative aerators of the Rain jet ensure a large flow of water, soft and pleasant, while guaranteeing a water consumption of only 8 liters per minute. They can be individually oriented to modulate the flow at will so as to experience an authentic relaxing moment. Thanks to the specific jet breaker and the abundant flow of water, the O3 laminar jet transforms the shower into a real sensory pampering. The uniqueness of the jet lies in the transparency and reduced speed of the flow which, in contact with the body, gives a pleasant regenerating sensation. The waterfall jet is designed to offer an energizing and vigorous massage. Its fast and decisive flow completely envelops the body and guarantees perfect relaxation even with low flow rates. The O3 shower head is available in a wide range of finishes, which make it ideal for enhancing any bathroom environment.

INSTALLALO
DOVE VUOI
COME VUOI

QUASI UN GIOCO DI MAGIA

ALMOST BY MAGIC



GETTO RAIN - RAIN FLOW

TRE INNOVATIVI AERATORI ASSICURANO UN AMPIO GETTO DI ACQUA, CHE PUÒ ESSERE ORIENTATO SINGOLARMENTE E MODULATO SECONDO IL GUSTO PERSONALE. LE SPECIALI TETTARELLE OFFRONO UN GETTO MORBIDO E PIACEVOLE, GARANTENDO UN CONSUMO IDRICO DI SOLI 8 LITRI AL MINUTO.

THREE INNOVATIVE AERATORS ENSURE A WIDE FLOW OF WATER, WITH THE POSSIBILITY OF EACH JET TO BE INDIVIDUALLY ORIENTED AND MODULATED ACCORDING TO PERSONAL TASTE. THE SPECIAL NIPPLES OFFER A SOFT AND PLEASANT JET, GIVING A WATER CONSUMPTION OF ONLY 8 LITERS PER MINUTE.



GETTO LAMINARE - LAMINAR FLOW

GRAZIE ALLO SPECIFICO ROMPIGETTO E ALL'ABBONDANTE FLUSSO D'ACQUA, QUESTA VERSIONE DI O3 TRASFORMA LA DOCCIA IN UN VERO MOMENTO DI BENESSERE E COMFORT. L'UNICITÀ DEL GETTO STA NELLA TRASPARENZA E NELLA RIDOTTA VELOCITÀ DEL FLUSSO CHE, A CONTATTO CON IL CORPO, REGALA UNA GRADEVOLE SENSAZIONE RIGENERANTE.

THANKS TO THE SPECIAL AERATOR AND TO THE FULL WATER FLOW, THIS VERSION OF O3 TRANSFORMS THE SHOWER EXPERIENCE INTO A TRUE MOMENT OF WELL-BEING AND RELAX. THE DISTINCTIVE FEATURE LIES IN THE TRANSPARENCY AND REDUCED SPEEDNESS OF THE FLOW, LEAVING YOUR BODY FEELING REPLENISHED AND REVITALIZED.



GETTO CASCATA - WATERFALL JET

IL GETTO A CASCATA È STUDIATO PER OFFRIRE UN MASSAGGIO ENERGIZZANTE E VIGOROSO. IL SUO FLUSSO VELOCE E DECISO, AVVOLGE COMPLETAMENTE IL CORPO E GARANTISCE UN PERFETTO RELAX ANCHE CON BASSE PORTATE.

THE WATERFALL IS DESIGNED TO OFFER AN ENERGIZING AND VIGOROUS MASSAGE. ITS FAST AND DECISIVE FLOW COMPLETELY WRAPS THE BODY AND GUARANTEES PERFECT RELAXATION EVEN WITH LOW FLOW RATES.



fima | CARLO FRATTINI®
rubinetterie

follow me



WWW.FIMACF.COM



FIMANEWS

2021

03

DAVIDE VERCELLI DESIGN

IN o OUT



STILL

DAVIDE VERCELLI DESIGN

UNA NUOVA
DIMENSIONE DI
BENESSERE

A NEW DIMENSION OF WELL-BEING

SWITCH

DAVIDE VERCELLI DESIGN

WWW.FIMACF.COM



SWITCH

DAVIDE VERCELLI DESIGN

UN SOLO PULSANTE, GRANDI FUNZIONALITÀ

ONE BUTTON, GREAT FEATURES

SWITCH rappresenta un sistema per la doccia ampio e completo, nato dalla costante tensione di migliorare l'esperienza delle azioni quotidiane attraverso gli oggetti, dalla necessità di un uso responsabile di risorse e materiali e dal ruolo centrale della personalizzazione.

Già a partire dal nome, SWITCH racconta uno dei suoi principali plus che lo rende unico nel settore dal punto di vista funzionale e di design: quello di "azionare" con la semplice pressione di un tasto a sfioro rotondo i flussi di acqua in corrispondenza dell'uscita stessa.

Questo innovativo sistema è declinato in tre versioni: a incasso, a mensola e a colonna, così da offrire all'utente finale la possibilità di scelta tra un sistema all in one, facilmente installabile e adatto anche agli interventi di ristrutturazione o un sistema, a incasso, completamente personalizzabile sulla base delle proprie esigenze estetiche e di spazio. La versione a incasso è caratterizzata da una serie di singoli elementi, ciascuno con funzioni differenti, che l'utente può disporre liberamente nello spazio, così da poter azionare i flussi di acqua in corrispondenza della rispettiva uscita.

Al contrario dei sistemi esistenti - in cui solo dalla posizione di regolazione della temperatura e del flusso è possibile azionare le varie utenze attraverso i deviatori - Switch fa corrispondere al tasto premuto la relativa uscita. È quindi possibile costruire il proprio sistema con la massima libertà compositiva e spaziale scegliendo tra diversi elementi, alimentabili indipendentemente o contemporaneamente, ciascuno con una specifica funzione: doccia, bocca a parete, getto laterale, tubo Kneipp e pulsante on/off.

SWITCH represents a wide and complete shower system, resulting from the constant striving to enhance the experience of daily activities through objects, from the need for a responsible way to use resources and materials and from the central role of customization.

Starting from the name, SWITCH points out one of its main pluses which makes it unique in the industry due to both its functionality and design: you can indeed turn on the water flows at the outlet itself by simply pushing a round infinity-edge button.

This innovative system is available in three versions: built-in, shelf and shower column. The end consumer has thus the chance to choose between an all-in-one system, easy to install and even suitable for renovations, or a built-in one, completely customizable to suit any aesthetic and space need.

The built-in version is made up of a series of single items, each one with different functions, that the user can arrange freely in the shower space. Unlike the existing systems - in which the different units can be only turned on by the diverters positioned in the control module - SWITCH matches the pressed button to the corresponding outlet. It is thereby possible to create your own shower system with the greatest design freedom by choosing from different items, supplied independently or simultaneously. Each one with a specific function: hand shower, water spout, side jet, Kneipp hand shower and ON/OFF Switch button.

DOCETTA F5925NS

La doccetta richiama con la sua distintiva texture godronata gli altri elementi della serie Switch. Il design ergonomico permette una presa agevole e il suo utilizzo diventa più naturale grazie all'aeratore posto in posizione verticale e al pulsante di comando integrato nella piastra.

HANSHOWER F5925NS

The handshower reminds the other items of Switch line thanks to its distinctive knurled texture. The ergonomic design offers an easy grip and its comfort is enhanced by the vertical jet and by the proximity of the push button.

BOCCA EROGAZIONE F5926NS

La bocca di erogazione è stata specificatamente sviluppata per essere integrata al sistema Switch. Innovativa è la possibilità di dislocare liberamente la bocca di erogazione in fase di installazione. Il pratico pulsante di comando permette un'immediata apertura dell'acqua.

WATER SPOUT F5926NS

The spout has been specially designed to be part of the Switch system. The unit can be installed in the desired position independently from the location of the control module. The handy push button turns on the water instantly.

PULSANTE ON/OFF F5922NS

L'elemento on/off può essere abbinato a qualsiasi punto di erogazione a parete. E' inoltre disponibile un kit di differenti tasti personalizzati e facilmente intercambiabili che permettono una facile identificazione dell'uscita corrispondente: getto laterale, soffione, doccetta, lama d'acqua.

ON/OFF BUTTON F5922NS

A handy push button turns on the water flow at the corresponding wall mounted outlet. A kit of different customized easily interchangeable buttons are available to identify the corresponding outlet: side jet, head shower, hand shower, water blade.



GETTO LATERALE F5923NS

Il getto laterale ad alta efficienza è orientabile e integrato nella piastra di comando per un facile accesso e una fruizione confortevole. Il pulsante è posto in corrispondenza del getto per permetterne una comoda attivazione. Le specifiche performance consentono di attivare contemporaneamente fino a 4 getti

SIDE JET F5923NS

The high-efficiency adjustable side jet, built in the control plate, is easily accessible and comfortable in use. Switch button and side spray are next to each other. Up to 4 jets can work at once offering the utmost comfort.

TUBO KNEIPP F5924NS

Grazie al suo specifico rompigetto e all'abbondante flusso d'acqua, il tubo kneipp regala una piacevole sensazione di benessere ad ogni utilizzo. Il pratico pulsante on/off integrato nella piastra ne permette l'agevole attivazione e la libera installazione all'interno dell'ambiente doccia.

KNEIPP HANDSHOWER F5924NS

Thanks to its particular aerator and its high water flow, the Kneipp hand shower gives a pleasant feeling of well-being at each use. The infinity-edge handy button enables an easy activation as well as a customized installation inside the shower area.





F5925CR + F5922CR + F5924CR

La versione a incasso di Switch consente due modalità installative: **LIBERA** e **LINEARE**. L'installazione libera offre una straordinaria autonomia progettuale, permettendo di distribuire liberamente all'interno dell'ambiente doccia tutti i componenti scelti per formare una composizione custom-made. L'installazione lineare invece è predefinita e facilitata grazie a un apposito binario, da incassare direttamente nel muro, su cui gli elementi vengono già forniti pre-installati.

The Switch built-in version offers two types of installation: **FREE** or **LINEAR**. The free installation gives you an outstanding design autonomy, enabling all the items to be freely arranged within the shower area in a customized way. The linear installation instead is preset and simplified thanks to a special plate, to be built directly into the wall, on which the items are supplied pre-installed.

“La zigrinatura verticale dei profili, crea un contrasto con le superfici lisce dando vita a un design unico e inconfondibile”

SWITCH INCASSO

Nel caso di installazione multipla la rimozione del tappo di arresto laterale permette l'allacciamento in serie di più elementi garantendo performance di erogazioni inalterate.

In case of multiple installation, the removal of the side sealing plug allows the connection in series of more fixtures guaranteeing unchanged performance of water delivery.

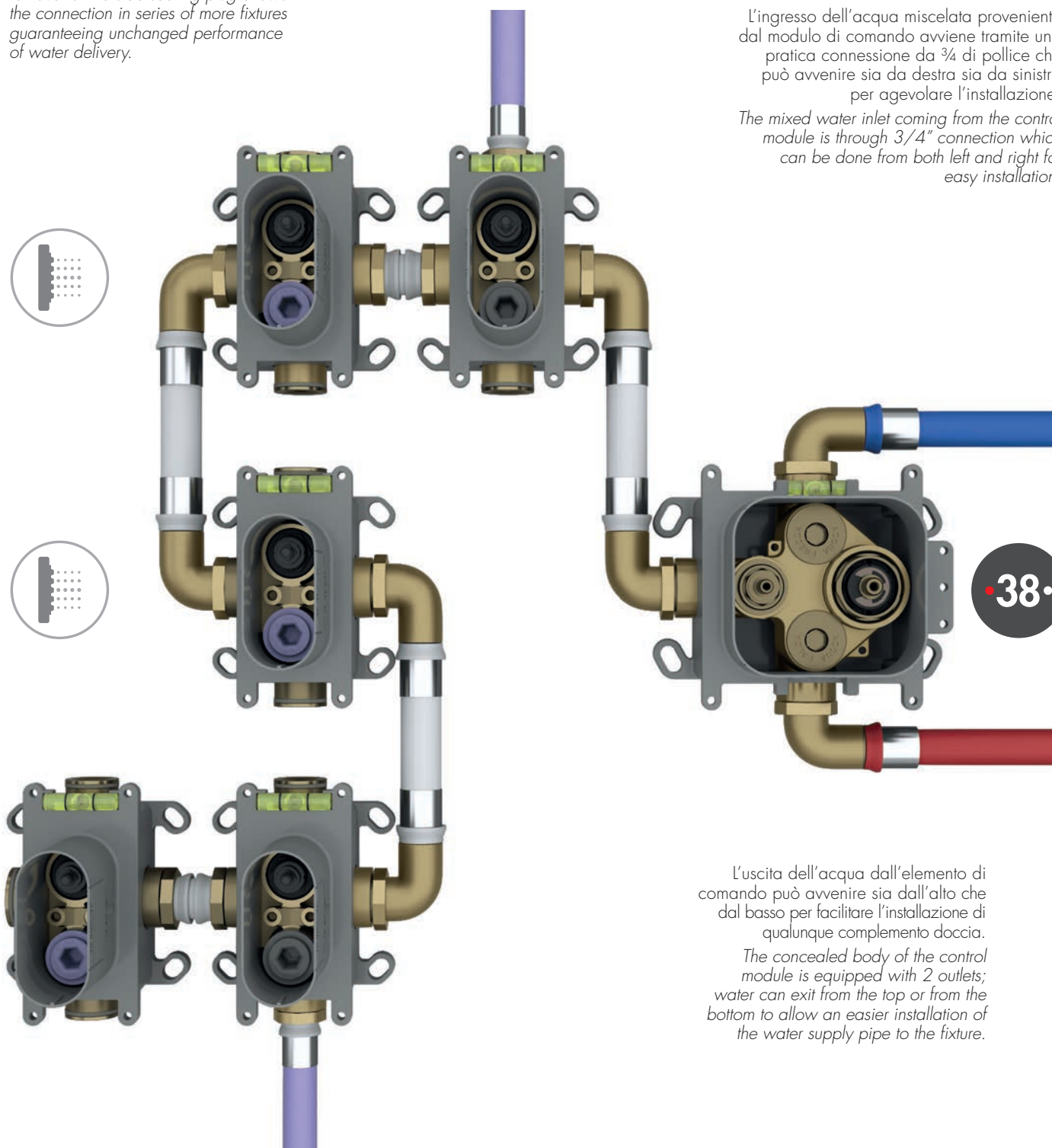
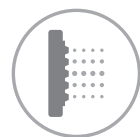

L'ingresso dell'acqua miscelata proveniente dal modulo di comando avviene tramite una pratica connessione da 3/4 di pollice che può avvenire sia da destra sia da sinistra per agevolare l'installazione.

The mixed water inlet coming from the control module is through 3/4" connection which can be done from both left and right for easy installation.

38

L'uscita dell'acqua dall'elemento di comando può avvenire sia dall'alto che dal basso per facilitare l'installazione di qualunque complemento doccia.

The concealed body of the control module is equipped with 2 outlets; water can exit from the top or from the bottom to allow an easier installation of the water supply pipe to the fixture.



Il caratteristico guscio protettivo garantisce facilità di installazione, protezione contro le infiltrazioni e isolamento acustico oltre a tutte le altre peculiarità comuni a tutta la serie FIMABOXES.

The protective casing allows an easy installation, protection against water infiltration and acoustic isolation in addition to all the other features we find in all FIMABOXES.

SWITCH INCASSO





F5923CR

Al centro dell'impianto, il blocco che regola temperatura e portata, anch'esso posizionabile liberamente nello spazio, comanda tutto il sistema e garantisce praticità di utilizzo e comfort. All'attivazione di ciascuna uscita, viene sempre erogato il quantitativo di acqua preimpostato all'ultimo utilizzo, che può andare da un minimo a un massimo di portata regolabile attraverso la rispettiva manopola di comando.

Per rendere le modalità di comando più agevoli, così da semplificare "l'esperienza doccia", il design delle due manopole di regolazione temperatura e portata è generoso e con un rilievo centrale raccordato alla base che ne permette una semplice fruizione. La superficie laterale è lavorata con una godronatura molto ampia che favorisce una facile presa laterale. Particolare attenzione è rivolta anche all'estetica e all'eco-sostenibilità: da un lato, grazie al contenimento dei volumi dei corpi a incasso, le dimensioni esterne e gli ingombri sono più discreti; dall'altro la naturale posizione verticale delle manopole è studiata in modo da "educare" a un uso più responsabile dell'acqua, invitando a utilizzare una portata che soddisfi le esigenze quotidiane e al contempo garantisca risparmio idrico.

At the centre of the system the control module adjusts the temperature and the flow rate. The module can be placed at random inside the shower enclosure and controls all fixtures, guaranteeing high functionality and comfort.

Each fixture connected to the module delivers water based upon the set flow rate that ranges from a minimum to a maximum and can be changed by means of a very practical knob. Both temperature and flow rate knobs are provided with a side knurled pattern to allow a better grip and a more comfortable use.

Special attention has been given to the aesthetics and to the sustainability, so that the small size of the concealed bodies reduces the dimensions of the external parts creating a minimal look and the vertical position of the lever of the flow rate knob wants to help the consumer to be water efficient, in fact in that position the flow rate is perfect to enjoy a shower guaranteeing water saving.

UN GRANDE CUORE CHE COMANDA OGNI COSA

A BIG HEART CONTROLLING EVERYTHING



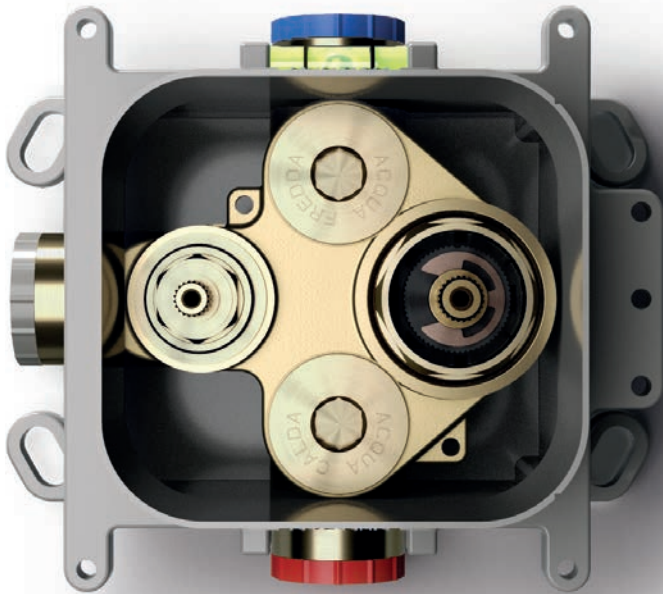

F4010

Il corpo a incasso del blocco di comando cela al suo interno una serie di innovazioni tecnologiche nate dall'approccio di continua ricerca e innovazione, condotto negli anni, nello sviluppo delle serie FIMABOXES. Gli ingressi dell'acqua calda e fredda da 3/4 di pollice, uniti agli elementi di controllo della temperatura e del flusso ad alta portata, garantiscono prestazioni costanti anche nel caso di utilizzo contemporaneo di più elementi di erogazione. I filtri e le valvole di non ritorno sono facilmente ispezionabili permettendo un'agevole manutenzione che garantisce inalterate performance nel tempo. Le scocche protettive e il caratteristico guscio, che assicura isolamento acustico e da infiltrazioni, ne consentono una facile installazione. Icone e colori appositamente studiati agevolano le connessioni di acqua calda e fredda e in caso di problemi, un innovativo sistema espressamente progettato, permette il funzionamento del blocco di comando anche in caso di installazione con acque invertite.

The concealed body of the control module presents several technological innovations, as a result of the ongoing research of Fima R&D Department over the years.

The 3/4" water inlets together with the temperature and the high flow rate knobs guarantee great performance delivering constant water even to multiple fixtures. Filters and non return valves can be easily inspected allowing fast maintenance to ensure a good performance throughout the years. The protective covers and the distinctive casing guarantee water and acoustic isolation and an easy installation. Icons and colours indicate hot and cold water inlets. In case of mistakes, an innovative system lets the control module work even with reversed water connection.



F4020

Un corpo a incasso studiato per il massimo comfort.

L'ingresso dell'acqua miscelata proveniente dal modulo di comando avviene tramite una pratica connessione da 1/2 pollice che può avvenire sia da destra sia da sinistra per agevolare l'installazione. Nel caso di installazione multipla la rimozione del tappo di arresto laterale permette l'allacciamento in serie di più elementi garantendo performance di erogazioni inalterate.

Il caratteristico guscio protettivo garantisce facilità di installazione, protezione contro le infiltrazioni e isolamento acustico oltre a tutte le altre peculiarità comuni a tutta la serie FIMABOXES.

L'uscita dell'acqua può essere configurata in modo frontale, superiore o inferiore in base alla disposizione scelta in fase di installazione. Le cover e i tappi protettivi garantiscono l'integrità del corpo fino all'installazione delle parti esterne.

A built-in body designed for the utmost comfort.

The mixed water inlet coming from the control module can be connected from the right or the left by means of a practical 1/2" entry. In case of multiple installation, the removal of the side sealing plug allows the connection in series of more fixtures guaranteeing unchanged performance of water delivery.

The protective casing allows an easy installation, protection against water infiltration and acoustic isolation in addition to all the other features we find in all FIMABOXES.

The water outlets can be upper, lower and/or frontal based upon the selected fixtures. The protective covers and the plugs guarantee the integrity of the concealed body before the installation of the external parts.

L'INNOVAZIONE DEL SISTEMA DOCCIA IN UNO SWITCH

THE INNOVATION OF THE SHOWER SYSTEM IN A SWITCH



SWITCH MENSOLA

Nell'immagine, SWITCH MENSOLA di FIMA Carlo Frattini proposto nella finitura nero opaco con vetro satinato scuro e doccetta. La tecnologia SWITCH è racchiusa all'interno di un corpo erogatore a due uscite che ha una doppia funzionalità: contenere i comandi nella parte frontale e fungere da pratica superficie di appoggio.

In the picture: FIMA's SWITCH MENSOLA in matt black finish with satined anthracite glass and handshower. SWITCH technology is built in a body with 2 outlets and 2 functions, on front of the body the buttons and knobs to turn on water and adjust flow and temperature and on the top a useful shelf.



La versione MENSOLA amplia le possibilità di installazione della serie e si contraddistingue per il fatto che tutto il sistema Switch è racchiuso in un corpo erogatore ridotto e dagli ingombri minimi.

I comandi di regolazione di temperatura e flusso sono stati integrati insieme ai due pulsanti di attivazione dell'uscita soffione e del doccino, massimizzando la praticità di utilizzo e donando uno stile unico e inconfondibile al sistema doccia.

Il doccino, elemento iconico della serie, richiama con la sua distintiva texture godronata gli elementi di comando. e Il design ergonomico permette una presa agevole e un utilizzo più naturale grazie all'aeratore posto in posizione verticale.

La pratica versione a MENSOLA è disponibile in finitura cromo, nickel spazzolato, nero e bianco opaco, viene abbinata a un ripiano in vetro satinato, di colore antracite nella versione nero opaco e di colore grigio chiaro in tutte le altre versioni, per uno stile distintivo a ogni ambiente doccia.

The MENSOLA (SHELF) version of the Switch series increases the possibilities for installations. For simplification the entire Switch system has been concentrated in a small compact body.

The temperature and waterflow controls have been added to the two on/off buttons of the shower head and handshower to be more functional and to conceive an unique design.

The knurled pattern of the iconic handshower recalls the design of the control module knobs and the ergonomic grip with the vertical aerator enable a natural shower experience.

The practical SHELF is available in the following stylish finishes - chrome, matt black, matt white and brushed nickel and is matched with a satined glass shelf, that is anthracite colour for the matt black version and light grey for all the other finishes, an additional distinctive touch to the shower.



SWITCH COLONNA



UN SISTEMA ALL-IN-ONE ALLA PORTATA DI TUTTI

AN ALL IN ONE SYSTEM

La versione a COLONNA, è un sistema all-in-one che deriva direttamente dalla versione mensola. E' particolarmente indicata per chi desidera rinnovare lo stile del proprio ambiente bagno senza dover affrontare importanti lavori di ristrutturazione, in quanto permette l'installazione sulle tradizionali uscite di acqua calda e fredda con interasse 150 mm. Il sistema Switch abbinato alla nuova colonna doccia è in grado di garantire benessere, funzionalità e un look inconfondibile.

A follow through from the SHELF version is the SHOWER COLUMN version of the SWITCH, which is the perfect answer for the client who wants to update the style of their bathroom with having to undertake renovation work. Designed for installation on traditional hot and cold water outlets with a 150mm wheelbase the Switch combined with the new shower column guarantees style, function and wellbeing.



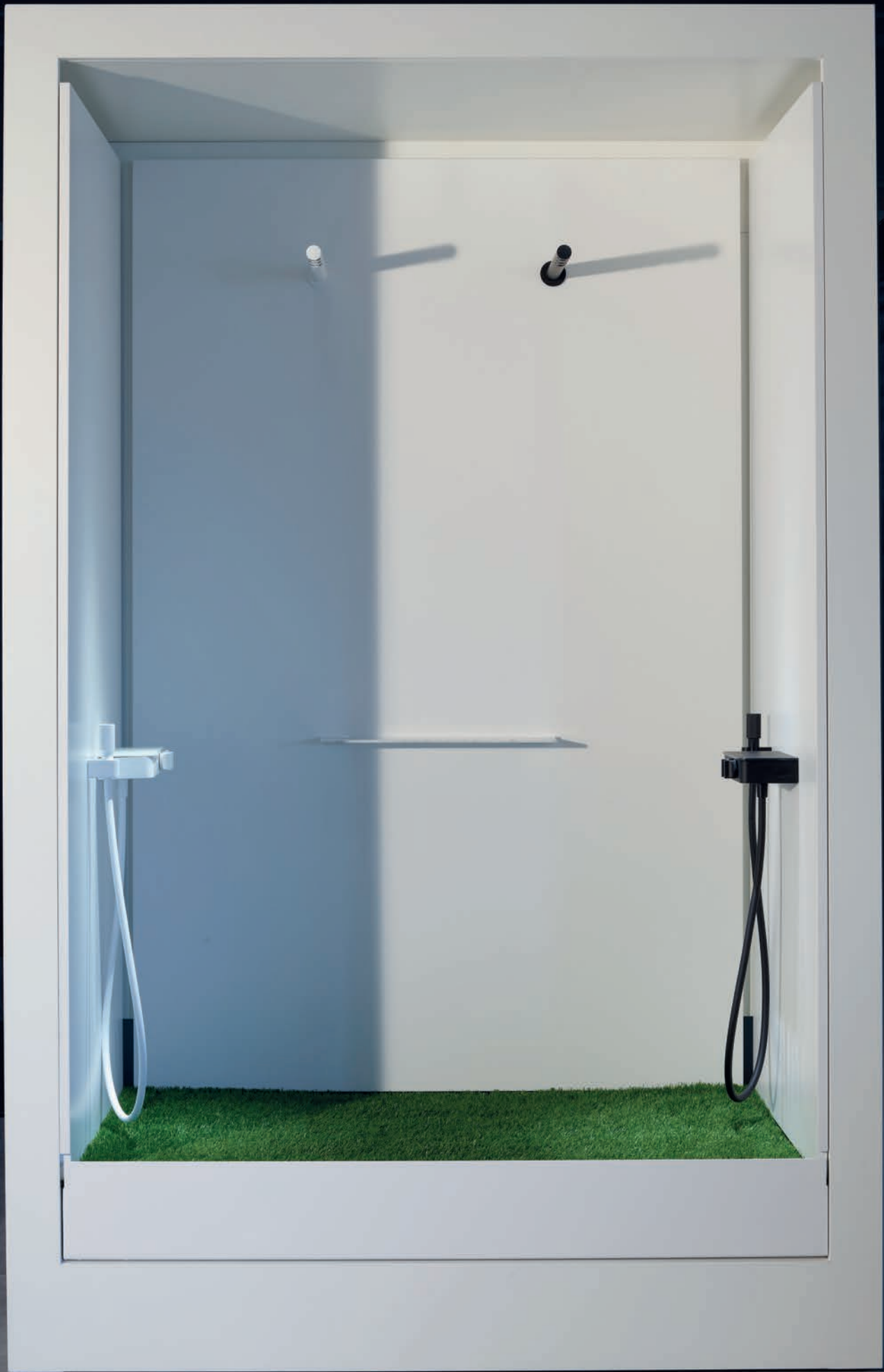

STILL

DAVIDE VERCELLI DESIGN

UN PROGETTO AMBIZIOSO CHE APRE UNA NUOVA DIMENSIONE DI BENESSERE

AN AMBITIOUS PROJECT THAT OPENS A
NEW DIMENSION OF WELL BEING

Ricerca estetica, rigore formale e distintive performance: nasce STILL di Fima Carlo Frattini, un progetto ambizioso che apre a una nuova dimensione di benessere. Il design minimale e all'avanguardia di questo nuovo soffione è l'espressione di un concept semplice e lineare capace di trasformare l'ambiente bagno in un luogo di relax: un unico elemento cilindrico al cui interno sono installati 3 aeratori orientabili singolarmente a piacere.

Le sue linee pulite ed essenziali esaltano il naturale movimento dell'acqua e l'approfondito studio ergonomico consente di vivere un'esperienza doccia memorabile e avvolgente garantendo un ridotto consumo idrico, di soli 8 litri di acqua al minuto.

Le performance di erogazione unite alla pulizia estetica della silhouette offrono un'ampia possibilità di personalizzazione grazie all'abbinamento più soffioni per creare composizioni doccia dal forte impatto estetico. Tutti i corpi FimaBoxes consentono di alimentare

con una sola uscita fino a due soffioni contemporaneamente, mentre quelli a incasso ad alta portata permettono l'utilizzo di più soffioni contemporaneamente dando vita a scenografiche configurazioni. Still rappresenta la soluzione ideale per riscoprire e vivere i benefici dell'acqua incontrando al contempo le esigenze stilistiche dell'abitare contemporaneo.

La palette di finiture oltre al classico cromo o nickel spazzolato si declina in tutte le finiture galvaniche quali il cromo nero, il cromo nero spazzolato, l'oro e l'oro spazzolato. Non mancano poi le finiture nero opaco e bianco opaco che grazie all'effetto soft touch, donano un carattere estremamente contemporaneo, perfetto per giocare con abbinamenti total look o in contrasto.

Il nuovo soffione Still si inserisce perfettamente all'interno della gamma di Fima Carlo Frattini, un progetto wellness integrato in grado di garantire funzionalità, benessere e un look inconfondibile.

STILL



F5912BS



F5912NS

Aesthetic research, formal rigor and distinctive performance: Still is born, an ambitious project that opens up to a new dimension of well-being. The minimal and avant-garde design of this new shower head is the expression of a simple and linear concept capable of transforming the bathroom in a place of relaxation: a single cylindrical element inside which 3 individually adjustable aerators are installed. Its clean and essential lines enhance the natural movement of water and the in-depth ergonomic study allows you to experience a memorable and enveloping shower experience, guaranteeing a reduced water consumption of only 8 liters of water per minute.

The delivery performance combined with the aesthetic cleanliness of the silhouette offer a wide range of customization possibilities thanks to the combination of multiple shower heads to create shower compositions with a strong aesthetic impact. All FimaBoxes bodies allow you to feed up to two shower heads simultaneously with a single outlet, while the high-flow recessed ones allow the use of multiple shower heads at the same time, giving rise to spectacular configurations. Still represents the ideal solution to rediscover and experience the benefits of water while meeting the stylistic needs of contemporary living. In addition to the classic chrome or brushed nickel, the palette of finishes is available in all the galvanic finishes such as black chrome, brushed black chrome, gold and brushed gold. There are also matt black and matt white finishes which, thanks to the soft touch effect, give an extremely contemporary character, perfect for playing with total look or contrasting combinations.

“Il suo design è l'espressione di un concept semplice e lineare: un singolo elemento cilindrico al cui interno sono installati 3 aeratori orientabili”

Its design is the expression of a simple concept: a single cylindrical element where 3 swiveling aerators are installed





DAVIDE VERCELLI DESIGN

RIFLETTORI PUNTATI SULLA PERSONALIZZAZIONE DEL BENESSERE

SPOTLIGHT ON THE CUSTOMIZATION OF WELLNESS

Un notevole impatto estetico e un design originale e innovativo sono la cifra distintiva del nuovo soffione O3, che gioca sulla possibilità di comporre l'ambiente wellness in modo personale per costruire la propria esperienza benessere grazie a tre diverse erogazioni.

Frutto di un ricercato e approfondito processo creativo strettamente legato allo sviluppo di prodotti incentrati sul design volti a migliorare sensibilmente l'esperienza doccia, a garantire un uso responsabile delle risorse e a esprimere le attuali tendenze, O3 si contraddistingue per il suo stile estremamente riconoscibile. A livello formale le scelte progettuali, votate alla funzionalità e al design, vedono l'abbinamento dinamico di due elementi cardine del soffione: un corpo cilindrico che eroga l'acqua e un particolare elemento di supporto e distribuzione con forma a "L". Questo elemento, a cui il corpo principale cilindrico del soffione è collegato a parete o a soffitto, ha la duplice funzione di portare l'acqua ai getti e di orientare il gruppo di erogazione, attraverso un innovativo sistema di snodo, in base alle esigenze del proprio rituale doccia. Segno peculiare è il suo sottile profilo, realizzato con tecnologie all'avanguardia, che con soli 6 mm di spessore rende l'erogazione dell'acqua quasi un gioco di magia.

A remarkable aesthetic impact and an original and innovative design are the distinctive features of the new O3 shower head, which plays on the possibility of composing the wellness environment in a personal way to build your own wellness experience thanks to three different dispensing options.

The result of a refined and in-depth creative process closely linked to the development of products focused on design aimed at significantly improving the shower experience, ensuring responsible use of resources and expressing current trends, O3 stands out for its extremely recognizable style. On a formal level, the design choices, devoted to functionality and design, see the dynamic combination of two key elements of the shower head: a cylindrical body that delivers water and a particular support and distribution element with an L shape. This element, to which the main cylindrical body of the shower head is connected to the wall or to the ceiling, has the dual function of bringing water to the jets and orienting the delivery unit, through an innovative joint system, according to the needs of the individual. shower ritual. A peculiar sign is its thin profile, made with cutting-edge technologies, which with only 6 mm thickness makes the water supply almost a magic game.

Il soffione O3 è disponibile in due differenti versioni che permettono di dare una precisa identità estetica all'ambiente bagno: IN e OUT. La prima - più tradizionale e dalla silhouette più compatta e pulita - prevede il posizionamento del cilindro erogatore all'interno dell'elemento a L, in allineamento con la connessione di alimentazione dell'acqua. Questa variante garantisce anche un'installazione lineare rispetto agli elementi di comando della doccia. La seconda, dona una connotazione inedita e originale grazie al posizionamento del cilindro erogatore all'esterno rispetto all'elemento distributore a L, che può essere collocato sia a destra sia a sinistra.

The O3 shower head is available in two different versions that allow you to give a precise aesthetic identity to the bathroom: IN and OUT. The first - more traditional and with a more compact and clean silhouette - involves the positioning of the dispensing cylinder inside the L-shaped element, in alignment with the water supply connection. This variant also guarantees a linear installation with respect to the shower control elements. The second gives a new and original connotation thanks to the positioning of the dispensing cylinder outside the L-shaped distributor element, which can be placed both on the right and on the left.



F5919CR

IN o OUT



F5915CR

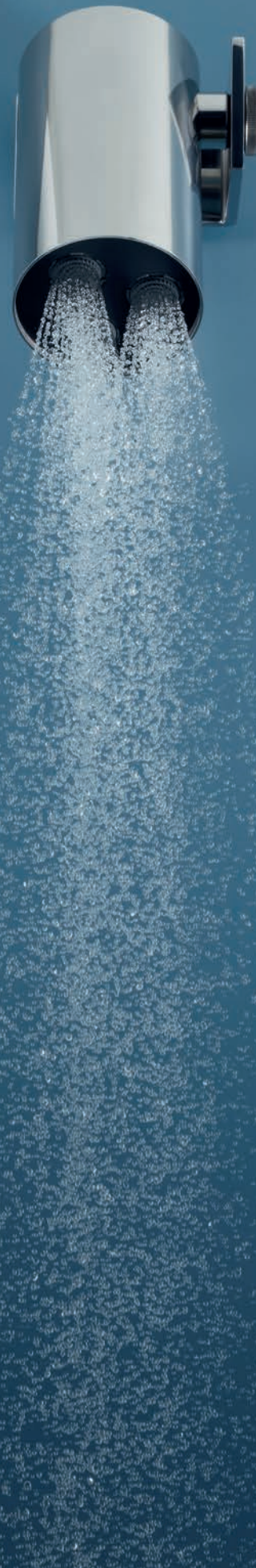



Per rendere l'ambiente bagno una vera oasi di benessere è possibile scegliere tra tre differenti modalità di erogazione: Rain, Laminare e Cascata. I tre innovativi aeratori del getto Rain assicurano un ampio flusso di acqua, morbido e piacevole, garantendo al contempo un consumo idrico di soli 8 litri al minuto. Possono essere orientati singolarmente per modulare a piacimento il flusso così da vivere un autentico momento rilassante. Grazie allo specifico rompigitto e all'abbondante flusso d'acqua, il getto Laminare di O3 trasforma la doccia in una vera coccola sensoriale. L'unicità del getto sta nella trasparenza e nella ridotta velocità del flusso che, a contatto con il corpo, regala una gradevole sensazione rigenerante. Il getto a cascata è studiato per offrire un massaggio energizzante e vigoroso. Il suo flusso veloce e deciso avvolge completamente il corpo e garantisce un perfetto relax anche con basse portate.

Il soffione O3 si declina in un ampio portfolio di finiture, che lo rendono ideale per valorizzare ogni ambiente bagno.

To make the bathroom a true oasis of well-being, you can choose between three different delivery modes: Rain, Laminar and Cascade. The three innovative aerators of the Rain jet ensure a large flow of water, soft and pleasant, while guaranteeing a water consumption of only 8 liters per minute. They can be individually oriented to modulate the flow at will so as to experience an authentic relaxing moment. Thanks to the specific jet breaker and the abundant flow of water, the O3 laminar jet transforms the shower into a real sensory pampering. The uniqueness of the jet lies in the transparency and reduced speed of the flow which, in contact with the body, gives a pleasant regenerating sensation. The waterfall jet is designed to offer an energizing and vigorous massage. Its fast and decisive flow completely envelops the body and guarantees perfect relaxation even with low flow rates. The O3 shower head is available in a wide range of finishes, which make it ideal for enhancing any bathroom environment.

INSTALLALO
DOVE VUOI
COME VUOI

QUASI UN GIOCO DI MAGIA

ALMOST BY MAGIC



GETTO RAIN - RAIN FLOW

TRE INNOVATIVI AERATORI ASSICURANO UN AMPIO GETTO DI ACQUA, CHE PUÒ ESSERE ORIENTATO SINGOLARMENTE E MODULATO SECONDO IL GUSTO PERSONALE. LE SPECIALI TETTARELLE OFFRONO UN GETTO MORBIDO E PIACEVOLE, GARANTENDO UN CONSUMO IDRICO DI SOLI 8 LITRI AL MINUTO.

THREE INNOVATIVE AERATORS ENSURE A WIDE FLOW OF WATER, WITH THE POSSIBILITY OF EACH JET TO BE INDIVIDUALLY ORIENTED AND MODULATED ACCORDING TO PERSONAL TASTE. THE SPECIAL NIPPLES OFFER A SOFT AND PLEASANT JET, GIVING A WATER CONSUMPTION OF ONLY 8 LITERS PER MINUTE.



GETTO LAMINARE - LAMINAR FLOW

GRAZIE ALLO SPECIFICO ROMPIGETTO E ALL'ABBONDANTE FLUSSO D'ACQUA, QUESTA VERSIONE DI O3 TRASFORMA LA DOCCIA IN UN VERO MOMENTO DI BENESSERE E COMFORT. L'UNICITÀ DEL GETTO STA NELLA TRASPARENZA E NELLA RIDOTTA VELOCITÀ DEL FLUSSO CHE, A CONTATTO CON IL CORPO, REGALA UNA GRADEVOLE SENSAZIONE RIGENERANTE.

THANKS TO THE SPECIAL AERATOR AND TO THE FULL WATER FLOW, THIS VERSION OF O3 TRANSFORMS THE SHOWER EXPERIENCE INTO A TRUE MOMENT OF WELL-BEING AND RELAX. THE DISTINCTIVE FEATURE LIES IN THE TRANSPARENCY AND REDUCED SPEEDNESS OF THE FLOW, LEAVING YOUR BODY FEELING REPLENISHED AND REVITALIZED.



GETTO CASCATA - WATERFALL JET

IL GETTO A CASCATA È STUDIATO PER OFFRIRE UN MASSAGGIO ENERGIZZANTE E VIGOROSO. IL SUO FLUSSO VELOCE E DECISO, AVVOLGE COMPLETAMENTE IL CORPO E GARANTISCE UN PERFETTO RELAX ANCHE CON BASSE PORTATE.

THE WATERFALL IS DESIGNED TO OFFER AN ENERGIZING AND VIGOROUS MASSAGE. ITS FAST AND DECISIVE FLOW COMPLETELY WRAPS THE BODY AND GUARANTEES PERFECT RELAXATION EVEN WITH LOW FLOW RATES.



fima | CARLO FRATTINI®
rubinetterie

follow me



WWW.FIMACF.COM





FIT



F3381/HBS





F3391LX8NS



FIT is all about minimalism, harmoniously combining square and round silhouettes and once again reflecting the engineering proficiency and innovation flair of the firm. FIT was born from a search for formal simplicity and, as suggested by the name itself, it is designed as a true multivalent and versatile product fit for every bathroom looking for a modern touch. Its lines are essential and pure, traced by flat and bold surfaces of matt black, polished chrome or glamorous matt white. Its sleek yet powerful look is enhanced by the slim spout.

Ein minimalistischer Ton und eine perfekte Kombination aus quadratischen und abgerundeten Linien zeichnen FIT aus, das aus der Suche nach formaler Einfachheit hervorgegangen ist und, wie der Name schon sagt, als echtes Passepartout-Produkt konzipiert wurde, das vielseitig und übergreifend für jedes Bad Ambiente ist und ein Gefühl der Modernität vermittelt. Reinheit und Wesentlichkeit der Geometrien sind die charakteristischen Merkmale dieses Modells, das sich durch flache Oberflächen auszeichnet und in der schwarz matt Version, in der glänzenden Chromoberfläche oder in der eleganten weiss matt Version verfügbar sind. Eine klare Ästhetik, aber mit einer starken Ausdruckskraft, die durch einen Auslauf mit einer sehr dünnen Silhouette verstärkt wird.

Un ton minimaliste et une combinaison parfaite de lignes carrées et arrondies caractérisent FIT, né de la recherche de la simplicité formelle et, comme son nom l'indique, conçu pour être un véritable produit passe-partout, polyvalent et transversal capable de dialoguer avec n'importe quel ambiente de bain donnant un sentiment de contemporanéité. La pureté et l'essentialité des géométries sont les traits distinctifs de ce modèle, définis par des surfaces planes, déclinées dans la version graveleuse noir mat, dans la finition chrome brillant ou dans l'élégant blanc mat. Une esthétique épurée mais avec un fort pouvoir expressif, sublimé par un bec avec une silhouette très fine.

FIT



F3399X2CR



F3381/H
Sleeve basin mixer
Waschtischbatterie hoch
Mitigeur lavabo rehaussé



F3381L
Wash basin mixer
Waschtischbatterie
Mitigeur lavabo



F3381
Wash basin mixer
Waschtischbatterie
Mitigeur lavabo



F3382
Bidet mixer
Bidetbatterie
Mitigeur bidet



F3391LX5
Wall mounted basin mixer
UP-Waschtischbatterie
Mitigeur lavabo encastré
spout - Auslauf - bec **200 mm**



F3391X8
Wall mounted basin mixer
UP-Waschtischbatterie
Mitigeur lavabo encastré
spout - Auslauf - bec **150 mm**



F3391LX8
Wall mounted basin mixer
UP-Waschtischbatterie
Mitigeur lavabo encastré
spout - Auslauf - bec **200 mm**



F3394
Deck mounted bath mixer
Wannenrandbatterie
Mitigeur baignoire sur gorge



F3384
Exposed bath mixer
with shower set
AP Wannenbatterie
mit Brauseset
Mitigeur baignoire
avec complet douche



F3385
Exposed shower mixer
with shower set
AP Brausebatterie
mit Brauseset
Mitigeur douche
avec complet douche



F3399X2
Single lever shower mixer for concealed
installation 2 outlet with shower set
UP Brausemischer 2 Ausgänge
mit Brauseset
Mitigeur douche encastré 2 sorties
avec ensemble de douche



F3383/1
Concealed shower mixer
UP Brausemischer
Mitigeur douche encastré



F3389X1
Concealed bath and shower mixer
UP Brausemischer
Mitigeur douche encastré



F3389X2
Concealed bath and shower mixer
with 2 outlets diverter
UP Brausemischer mit 2
Wege-Umsteller
Mitigeur bain/douche encastré
avec inverseur à 2 sorties



F3389X6
Concealed bath and shower mixer
with 2/3 outlets diverter
UP Brausemischer mit 2/3
Wege-Umsteller
Mitigeur bain/douche encastré
avec inverseur à 2/3 sorties



WASH BASIN AND BIDET MIXERS - WASCHTISCH- UND BIDETBATTERIEN - MITIGEURS LAVABO ET BIDET

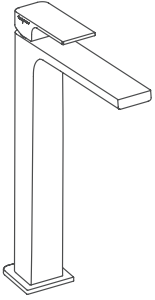

Sleeve basin mixer with click clack pop-up waste
Waschtischbatterie hoch mit Push-open Ablaufgarnitur
Mitigeur lavabo rehaussé avec vidage à pression

WATER SAVING 5 LT/min

F3381/HCR
F3381/HBS
F3381/HNS



F3381/HCR.ES
F3381/HBS.ES
F3381/HNS.ES

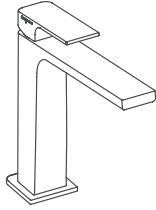

Wash basin mixer with pop-up waste
Waschtischbatterie mit Ablaufgarnitur
Mitigeur lavabo avec vidage

WATER SAVING 5 LT/min

F3381LCR
F3381LBS
F3381LNS



F3381LCR.ES
F3381LBS.ES
F3381LNS.ES

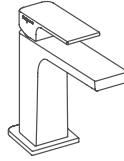

Wash basin mixer with pop-up waste
Waschtischbatterie mit Ablaufgarnitur
Mitigeur lavabo avec vidage

WATER SAVING 5 LT/min

F3381CR
F3381BS
F3381NS



F3381CR.ES
F3381BS.ES
F3381NS.ES

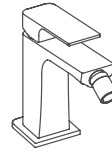

Bidet mixer with pop-up waste
Bidetbatterie mit Ablaufgarnitur
Mitigeur bidet avec vidage

WATER SAVING 5 LT/min

F3382CR
F3382BS
F3382NS



F3382CR.ES
F3382BS.ES
F3382NS.ES

WALL MOUNTED WASH BASIN MIXERS - UP-WASCHTISCHBATTERIEN - MITIGEURS LAVABO ENCASTRÉ

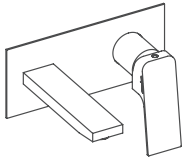

Wall mounted basin mixer with click clack pop-up waste. Spout 150 mm (**F3500** built-in part to be ordered separately)

UP-Waschtischbatterie mit Push-open Ablaufgarnitur. Auslauf 150 mm. (UP-Körper **F3500** separat zu bestellen)

Mitigeur lavabo encastré avec vidage à pression - bec 150mm (corps encastrable **F3500** à commander séparément)

WATER SAVING 5 LT/min

F3391X5CR
F3391X5BS
F3391X5NS

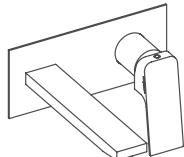

Wall mounted basin mixer with click clack pop-up waste. Spout 200 mm (**F3500** built-in part to be ordered separately)

UP-Waschtischbatterie mit Push-open Ablaufgarnitur. Auslauf 200 mm. (UP-Körper **F3500** separat zu bestellen)

Mitigeur lavabo encastré avec vidage à pression - bec 200mm (corps encastrable **F3500** à commander séparément)

WATER SAVING 5 LT/min

F3391LX5CR
F3391LX5BS
F3391LX5NS

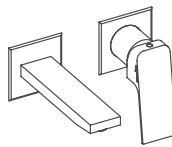

Wall mounted basin mixer with click clack pop-up waste. Spout 150 mm (**F3520** built-in part to be ordered separately)

UP-Waschtischbatterie mit Push-open Ablaufgarnitur. Auslauf 150 mm. (UP-Körper **F3520** separat zu bestellen)

Mitigeur lavabo encastré avec vidage à pression - bec 150mm (corps encastrable **F3520** à commander séparément)

WATER SAVING 5 LT/min

F3391X8CR
F3391X8BS
F3391X8NS

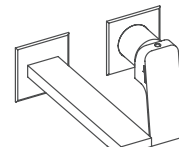

Wall mounted basin mixer with click clack pop-up waste. Spout 200 mm (**F3520** built-in part to be ordered separately)

UP-Waschtischbatterie mit Push-open Ablaufgarnitur. Auslauf 200 mm. (UP-Körper **F3520** separat zu bestellen)

Mitigeur lavabo encastré avec vidage à pression - bec 200mm (corps encastrable **F3520** à commander séparément)

WATER SAVING 5 LT/min

F3391LX8CR
F3391LX8BS
F3391LX8NS

BATH MIXERS - AP WANNENBATTERIEN - MITIGEURS BAIGNOIRE

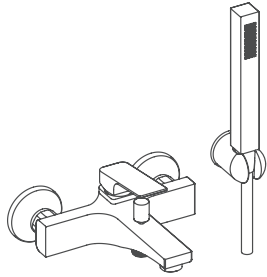

Exposed bath mixer
with shower set
AP Wannebatterie
mit Brauseset
Mitigeur baignoire
avec complet douche

F3384CR
F3384BS
F3384NS

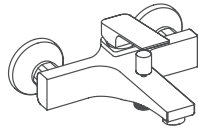

Exposed bath mixer
without shower set
AP Wannebatterie
ohne Brauseset
Mitigeur baignoire
sans complet douche

F3384/1CR
F3384/1BS
F3384/1NS

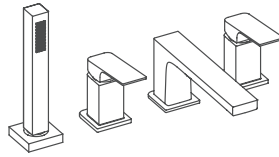

Deck mounted bath mixer
with spout
Wannenrandbatterie
mit Auslauf
Mitigeur baignoire sur gorge
avec bec

F3394CR
F3394BS
F3394NS

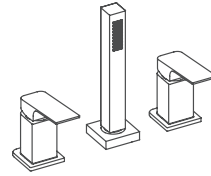

Deck mounted bath mixer
without spout
Wannenrandbatterie
ohne Auslauf
Mitigeur baignoire sur gorge
sans bec

F3394/1CR
F3394/1BS
F3394/1NS

SHOWER MIXERS - AP BRAUSEBATTERIEN - MITIGEURS DOUCHE

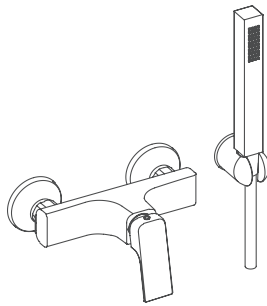

Exposed shower mixer
with shower set
AP Brausebatterie
mit Brauseset
Mitigeur douche
avec complet douche

F3385CR
F3385BS
F3385NS

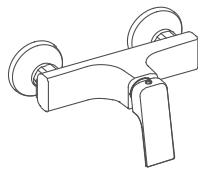

Exposed shower mixer
without shower set
AP Brausebatterie
ohne Brauseset
Mitigeur douche
sans complet douche

F3385/1CR
F3385/1BS
F3385/1NS

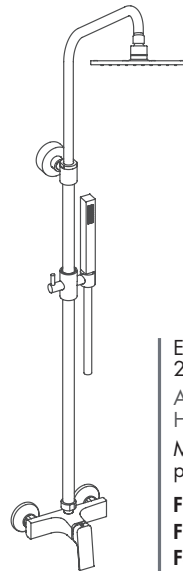

Exposed shower mixer with shower column, showerhead
250x250 mm, shower set and flexible cromalux 1500 mm
AP Brausebatterie mit Duschstange, Kopfbrause 250x250 mm,
Handbrause und Chromalux Schlauch 1500mm
Mitigeur douche mécanique avec colonne réglable en hauteur,
pomme de tête 250x250 mm, douchette, flexible cromalux 1500mm

F3385/2CR
F3385/2BS
F3385/2NS

SINGLE LEVER BATH AND SHOWER MIXERS - UP BRAUSEMISCHERN - MITIGEURS DOUCHE ENCASTRÉ

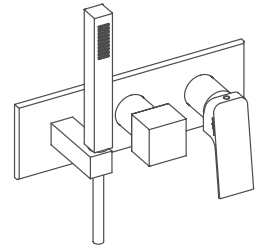
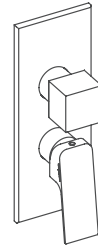
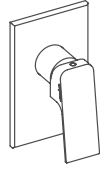

Single lever bath and shower mixer for concealed installation (**F2535** built-in part to be ordered separately)

UP Brausemischer (UP-Körper **F2535** separat zu bestellen)

Mitigeur douche encastré (corps encastrable **F2535** à commander séparément)

F3383/1CR
F3383/1BS
F3383/1NS

Single lever bath and shower mixer for concealed installation (**F3000** built-in part to be ordered separately)

UP Brausemischer (UP-Körper **F3000** separat zu bestellen)

Mitigeur douche encastré (corps encastrable **F3000** à commander séparément)

F3389X1CR
F3389X1BS
F3389X1NS

Single lever bath and shower mixer for concealed installation with 2 outlet diverter (**F3000** built-in part to be ordered separately)

UP Brausemischer mit 2 Wege -Umsteller (UP-Körper **F3000** separat zu bestellen)

Mitigeur bain/douche encastré avec inverseur à 2 sorties (corps encastrable **F3000** à commander séparément)

F3389X2CR
F3389X2BS
F3389X2NS

Single lever bath and shower mixer for concealed installation with 2/3 outlet diverter (**F4000** built-in part to be ordered separately)

UP Brausemischer mit 2/3 Wege -Umsteller (UP-Körper **F4000** separat zu bestellen)

Mitigeur bain/douche encastré avec inverseur à 2/3 sorties (corps encastrable **F4000** à commander séparément)

F3389X6CR
F3389X6BS
F3389X6NS

Single lever bath and shower mixer for concealed installation 2 outlet with shower set (**F3300** built-in part to be ordered separately)

UP Brausemischer 2 Ausgänge mit Brauseset (UP-Körper **F3300** separat zu bestellen)

Mitigeur douche encastré 2 sorties avec ensemble de douche (corps encastrable **F3300** à commander séparément)

F3399X2CR
F3399X2BS
F3399X2NS

BUILT-IN PARTS - UP KÖRPER - CORPS ENCASTRABLE

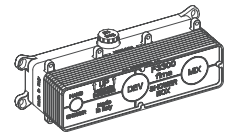
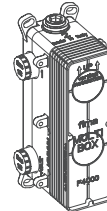
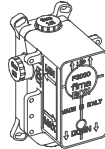
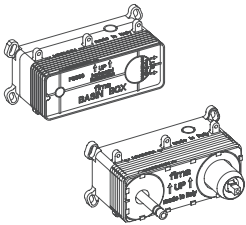

Built-in part to be ordered separately

UP-Körper separat zu bestellen

Corps encastrable à commander séparément

F3500
F3520CR
F3520BS
F3520NS

Built-in part to be ordered separately

UP-Körper separat zu bestellen

Corps encastrable à commander séparément

F2535CR
F2535BS
F2535NS

Built-in part to be ordered separately

UP-Körper separat zu bestellen

Corps encastrable à commander séparément

F3000

Built-in part to be ordered separately

UP-Körper separat zu bestellen

Corps encastrable à commander séparément

F4000

Built-in part to be ordered separately

UP-Körper separat zu bestellen

Corps encastrable à commander séparément

F3300

VISIT OUR WEBSITE WWW.FIMACF.COM FOR TECHNICAL DRAWINGS

BESUCHEN SIE UNSERE WEBSEITE WWW.FIMACF.COM FÜR DIE TECHNISCHEN MAß-SKIZZEN

VEUILLEZ CONSULTER NOTRE SITE INTERNET POUR LES FICHES TECHNIQUES WWW.FIMACF.COM



LIVE. LOVE.

FIT

Fima Carlo Frattini S.p.A.
28010 - Briga Novarese (NO)
Via Borgomanero, 105
tel. +39 0322 9549 (r.a.)
fax. +39 0322 956149
info@fimacl.com
www.fimacl.com

fima | CARLO FRATTINI®
r u b i n e t t e r i e

EN DE CH



GALILEO

M A G A Z I N E



UNA
RIVOLUZIONE
NELLA
RUBINETTERIA
DA CUCINA

A REVOLUTION
IN THE KITCHEN

WWW.FIMACF.COM

fima | CARLO FRATTINI®
r u b i n e t t e r i e



BERTONE DESIGN GALILEO

BERTONE DESIGN RAPPRESENTA CON LA SUA STORIA
L'ECCELLENZA ITALIANA IN TUTTO IL MONDO:
DAL CONCEPT DESIGN ALLA REALIZZAZIONE DEL PROGETTO,
OGNI LAVORO DI BERTONE È FRUTTO DI UN PENSIERO
INNOVATIVO LEGATO AD UNA SOLIDA ESPERIENZA
MATURATA NEL SETTORE AUTOMOTIVE.

La Bertone, fondata nel 1912, è una delle più antiche e prestigiose firme del "made in Italy" nel settore dell'automobile e ne ha accompagnato l'evoluzione tecnologica e stilistica attraverso il suo primo secolo di vita.

Con le grandi fuoriserie, dagli esordi dell'azienda agli anni Trenta, hanno entusiasmato il pubblico dei più esigenti collezionisti e "gentleman-driver". Sotto la guida di Nuccio, figlio del fondatore, la Bertone entra a vele spiegate negli anni Sessanta, cavalcando il "boom" economico con vetture destinate ad entrare nella storia, ancora una volta sintesi di alta sartoria e tecnologia d'avanguardia.

L'evoluzione del settore automotive porta ad una ristrutturazione del gruppo. La Bertone design riparte dal valore del marchio, sotto la guida di Aldo Cingolani, e opera nei settori di architettura e design, industrial design e trasporti, con un team di grande esperienza realizzando progetti in tutto il mondo.

Bertone Design, with its history, represents the Italian strength all over the world: from the concept design to the project realization, each Bertone's work is a result of innovative thinking combined with solid experience, developed in the automotive sector.

Founded in 1912, Bertone is one of the oldest and most prestigious «made in Italy» firms in the sector of automobiles, and it has accompanied the automotive industry's technological and stylistic evolution during the first century of its existence.

From its creation to the 1930s, Bertone aroused the enthusiasm of a demanding public of collectors and gentleman drivers with its "Fuori Serie" cars. Under the guidance of Nuccio, the founder's son, Bertone entered the 1960s with great success, riding the wave of the Italian economic boom and developing cars that would enter history as a result of highly skilled tailoring and leading edge technology.

The evolution of automotive sector led to the restructuring of the group. Bertone Design relaunched the value of the brand, combined with a highly experienced team of professionals under the leadership of Aldo Cingolani. Bertone Design now operates in the sector of architecture, design, industrial design and transportation, carrying out high quality projects all over the world.





LINEE AERODINAMICHE E SFIDANTI
CHE RICHIAMANO IL MONDO AUTOMOTIVE,
TRATTO DISTINTIVO DELLO STUDIO.

Aerodynamic and bold lines inspired by automotive
sector, a distinctive trait of the Studio.







GALILEO

BERTONE DESIGN

UNA RIVOLUZIONE NELLA RUBINETTERIA DA CUCINA

A REVOLUTION IN THE KITCHEN

Fima Carlo Frattini presenta Galileo, il nuovo rubinetto da cucina della divisione FIMA Kitchen disegnato da Bertone Design, che si caratterizza per le linee aerodinamiche e sfidanti che richiamano il mondo automotive, tratto distintivo dello Studio.

Dal carattere originale e minimal, Galileo trae ispirazione dalla forma del telescopio di Galileo Galilei, del quale ne eredita il nome, reinterpretandolo in chiave futuristica.

Un concept che nasce dall'obiettivo di creare un rubinetto che concilia un design unico e riconoscibile nel suo genere con un'elevata funzionalità ed ergonomia, fil-rouge dei progetti di Bertone Design e di Fima Carlo Frattini.

Galileo si struttura in tre componenti principali studiate per rendere più semplice l'interazione e accrescere la qualità della vita in cucina: la base, il blocco di comando e il doccino basculante.

Fima Carlo Frattini Kitchen Division unveils Galileo, the new kitchen mixer with an innovative swivelling spout, designed by Bertone Design. It features aerodynamic and bold lines typical of the automotive sector, a distinctive trait of the Studio.

Galileo takes inspiration from the shape of Galileo Galilei's telescope, hence the name, with a futuristic interpretation that creates an original and minimal design.

The result is a kitchen mixer that combines an unique and distinctive design with high functionality and ergonomics, fil-rouge of Bertone Design and Fima Carlo Frattini's projects.

Galileo has three main components, engineered to make the movement easier and to improve the performance in the kitchen: the base, the core and the swivelling removable spout.



GALILEO



CORPO PROTRATTO IN
AVANTI PER MIGLIORARE
LE PRESTAZIONI.
THE BODY IS INCLINED
FORWARD TO IMPROVE
THE PERFORMANCE.



Il corpo protratto in avanti, è studiato per agevolare le operazioni in cucina e rende Galileo adatto a ogni tipo di installazione e tipologia di lavello.

Inoltre l'ampia basetta, integrata nella parte bassa, contribuisce non solo all'estetica del prodotto, slanciandolo e donando eleganza, ma ne facilita il montaggio su qualsiasi piano.

The body is inclined forward to improve the performance and to allow Galileo to fit perfectly to every kind of installation and sink. The wider base enhances its elegance and allows for easier installation on all worktops.

GALILEO

UNA SOLUZIONE
SMART DAL FORTE
APPEAL ESTETICO
A SMART SOLUTION WITH A
STRONG AESTHETIC APPEAL





Cuore del miscelatore è il blocco di comando. Posizionato sulla parte alta della base, garantisce comodità di utilizzo in qualsiasi situazione quotidiana e conferisce leggerezza e pulizia formale.

Al suo interno alloggia la manopola: semplificata all'estremo, si contraddistingue per lo stile raffinato e il look minimale e contemporaneo. In fase di installazione l'utente può decidere se configurarla con o senza il caratteristico pin in contrasto che permette - con un semplice gesto - di regolare il flusso e la temperatura dell'acqua, agevolando l'utente e minimizzando al contempo i consumi.

Grazie alla rotazione dell'intero blocco di comando sulla base è possibile modificare non solo la direzione del getto ma anche l'orientamento della manopola, facilitando così la vista dei comandi da ogni angolazione e rendendo più confortevole l'uso quotidiano.

The core is the control center of the mixer. Positioned at the top of the base for easier use in everyday situations, it has a clean and elegant design.

The handle, extremely simplified, gives a minimal and contemporary look with the option of a distinctive pin lever that is included in the packaging and can be easily added if consumers opt for it.

The pin lever has the same finish as the flexible hose, a unique touch to every detail.

The core swivels to allow consumers to change the direction of the flow and the position of the handle.

GALILEO





Tutte queste peculiarità rendono Galileo un prodotto funzionale alla vita di tutti i giorni che si inserisce perfettamente all'interno della scena domestica. Non solo, con Galileo l'efficienza si allea con la ricerca stilistica, valorizzando lo spazio cucina con le sue forme avveniristiche e la varietà di configurazioni.

Galileo è, infatti, disponibile in diverse finiture galvaniche – cromo, cromo nero, cromo nero spazzolato – e nelle tonalità bianco opaco e nero opaco. In base alla finitura scelta il flessibile crea un total look nelle versioni bianco e nero oppure un effetto di contrasto materico giocato nei toni del nero se abbinato alle finiture galvaniche. In quest'ultima versione si aggiunge anche un originale rimando cromatico tra il pin di contrasto e il flessibile che ne amplifica il mood sofisticato.

Galileo è inoltre proposto nella versione FIMA Edition One, prodotta in esemplari limitati, che si contraddistingue per il colore nero mat abbinato al distintivo flessibile rosso. La scelta di questa palette oltre a esprimere e richiamare l'univocità del brand Fima Carlo Frattini, evoca e crea una stretta connessione con le tonalità tipiche del mondo delle auto da corsa. Il risultato è un prodotto dal carattere unico ed estremamente accattivante, protagonista indiscusso di ogni ambiente. L'esclusività di FIMA Edition One risiede nel numero di serie univoco che la identifica e nell'elegante packaging dedicato.

All these distinctive features make Galileo an extremely functional product to everyday use that fits perfectly to the domestic setting. Not only, efficiency allies with stylistic research and Galileo enhances the kitchen space thanks to its futuristic look and many configurations.

The rich variety of options is given by the multiple combinations of finishes between body spout and flexible hose.

Galileo is available in several galvanic finishes, chrome, black chrome, brushed black chrome, and in matt white and matt black colours. The color of the flexible hose changes based upon the finishes of the body. In matt white and matt black it creates a total look while with all galvanic finishes it is black to create a materic contrast, in combination with the pin lever.

Galileo is offered in FIMA Edition One a limited edition of pieces in the version matt black colour with the unique red hose, a strong detail that reminds to Fima's brand identity and suggests to the automotive trait of luxury sportive cars.

It gives a memorable experience and creates a new interesting scenario in the evolution of kitchen tapware. Fima Edition One is offered to a selective number of customers, it's identified by a unique serial number and an elegant packaging expressly.



Il doccino basculante è innestato lateralmente al blocco di comando attraverso un innovativo sistema magnetico, che consente anche di personalizzare in ogni momento l'inclinazione del getto. L'utente può così selezionare l'esatta posizione del doccino in ogni situazione adattando il prodotto all'esigenza contingente.

The swivelling spout is attached to the side of the core by means of an innovative magnetic system that allows a comfortable and safe inclination of the spout. Depending on the size of the sink and on its depth, the spout can be positioned to the best inclination for the best performance. The flexible hose gives an extended mobility to the removable spout. Its length is fixed but it can vary and be set based upon the wishes and the needs of the consumer during installation, improving once again the performance and the comfort.



UN INNOVATIVO
SISTEMA MAGNETICO,
CHE CONSENTE
DI PERSONALIZZARE
L'INCLINAZIONE
DEL GETTO.

AN INNOVATIVE
MAGNETIC SYSTEM
THAT ALLOWS A
COMFORTABLE AND
SAFE INCLINATION
OF THE SPOUT
AND WATER FLOW.





#GALILEOCOLORS



CROMO
CHROME
F7050CR



CROMO NERO
BLACK CHROME
F7050CN



CROMO NERO SPAZZOLATO
BRUSHED BLACK CHROME
F7050CS



BIANCO OPACO
WHITE MATT
F7050BS



NERO OPACO
BLACK MATT
F7050NS



NERO OPACO/ROSSO
BLACK MATT/RED
F7050RNS

fima | CARLO FRATTINI®
r u b i n e t t e r i e

follow me



WWW.FIMACF.COM



KITCHEN

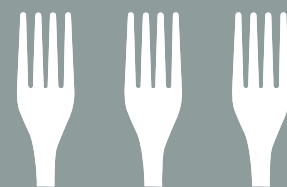

EVOLUTION

#KITCHEN

KITCHEN

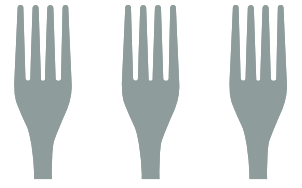

EVOLUTION

#KITCHEN

#INDICE

INDEX

COMPANY	06
GREEN QUALITY DESIGN	08
KITCHEN COLLECTION	10
GALILEO	12
SKINNY	16
FLEXI	20
STEEL	28
NOMOS	32
FLUID	34
SWING	38
GHOST	40
SETTANTA29	42
MAST	46
SPILLO	50
CLASSICI	52
GAMMA COMPLETA	59

#COMPANY

Tecnologia, estetica ed elevate prestazioni: FIMA Carlo Frattini propone da oltre 50 anni rubinetteria di altissima qualità destinata a durare nel tempo e capace di dare valore aggiunto ad ogni progetto. L'Azienda ha assunto negli anni un taglio innovativo ed in continua evoluzione, grazie alla creatività, al design e alle nuove tecnologie, che differenziano le sue collezioni. FIMA, infatti, si rinnova costantemente, come dimostrano l'alto livello progettuale e qualitativo della produzione, i continui investimenti in ricerca, la forte espansione nazionale e internazionale, la professionalità del team aziendale. Questo atteggiamento ha portato l'Azienda ad interpretare e anticipare le esigenze contemporanee e future del mercato, proponendo prodotti all'avanguardia per design e tecnologia, curati singolarmente in ogni dettaglio.

Technology, aesthetics and performance: FIMA Carlo Frattini has been offering for more than 50 years high quality faucets designed to last over time and able to give added value to each project. Over the years the Company has taken an innovative and evolving feature, thanks to its creativity, design and new technologies, which differentiate its collections from others. FIMA, in fact, is being continually upgraded by way of its high level of design, quality of production, continuous investments in research, the strong national and international expansion and the professionalism of the corporate team. This attitude has led the company to understand and anticipate the contemporary and future market needs by offering technically and esthetically advanced products, which are treated individually in every detail.



fima | CARLO FRATTINI
CONSTRUTTORE





#GREEN

FIMA CARLO FRATTINI da anni evolve i propri processi produttivi finalizzandoli ad una costante riduzione di risorse, materiali ed energia ed operando un controllo costante sulle materie prime, sui consumi e sull'impatto ambientale di tutte le fasi di produzione e commercializzazione dei propri prodotti.

Un'azienda eco sostenibile, alimentata da energia auto-prodotta e in grado di realizzare prodotti sicuri per la salute e per l'ambiente con un basso impatto ambientale.

FIMA CARLO FRATTINI has been for many years constantly developing its production processes in order to reduce the use of resources, materials and energy. Furthermore, all FIMA Carlo Frattini projects are developed considering all the steps of a product's life, from its manufacturing to the shipment till its dismantlement.

An environmentally friendly company, powered by self-produced electricity and able to produce products safe for human health and the environment with a very low environmental impact.

#QUALITY

I migliori materiali e tecnologie all'avanguardia per garantire un utilizzo quotidiano impassibile al trascorrere del tempo. Fima Carlo Frattini sposa un approccio globale alla qualità che deriva da un'attenzione all'innovazione tecnologica, adottando processi industriali all'avanguardia, scegliendo le migliori materie prime. Tutti i prodotti vengono sottoposti a minuziosi e severi controlli in ogni fase di lavorazione e sono progettati in modo da rispettare tutte le più rigide normative internazionali. Ulteriore testimonianza di questa filosofia improntata alla qualità totale è la garanzia che si estende per ben 7 anni su tutta la produzione.

Best materials and cutting-edge technologies as a guarantee for an everyday use unchanging over time. FIMA Carlo Frattini follows a global approach to quality coming from a particular attention to technology innovation, by adopting cutting-edge industrial processes, choosing the best raw materials. Detailed strict controls are carried out on all the products in every production phase and all the items are designed in order to respect the most stringent international regulations. Its seven-year extended warranty on all the product is a further evidence of this philosophy based on total quality.

#DESIGN

Prodotti unici nel loro genere, studiati per massimizzare il comfort di utilizzo e con un inconfondibile tocco Made in Italy. Convinta del potere della creatività, del design e delle nuove tecnologie, l'Azienda ha assunto negli anni un taglio innovativo e in continua evoluzione. Questo atteggiamento l'ha portata a interpretare e anticipare le esigenze presenti e future del mercato, proponendo prodotti all'avanguardia per design e tecnologia. Studiati per massimizzare il comfort di utilizzo e caratterizzati da uno stile unico sono progettati da nomi noti del design.

One-of-a-kind products, designed to maximize the comfort in use with an unmistakable hint of Made in Italy. The Company, firmly confident of the power of creativity, design, and new technologies, has developed over the years innovative and ever-changing traits. This approach has led it to interpret and anticipate the current and future market needs, by proposing state-of-the-art products in terms of design and technology. Designed to maximize the comfort in use and characterised by a unique style, all the items are designed by well-known designers.



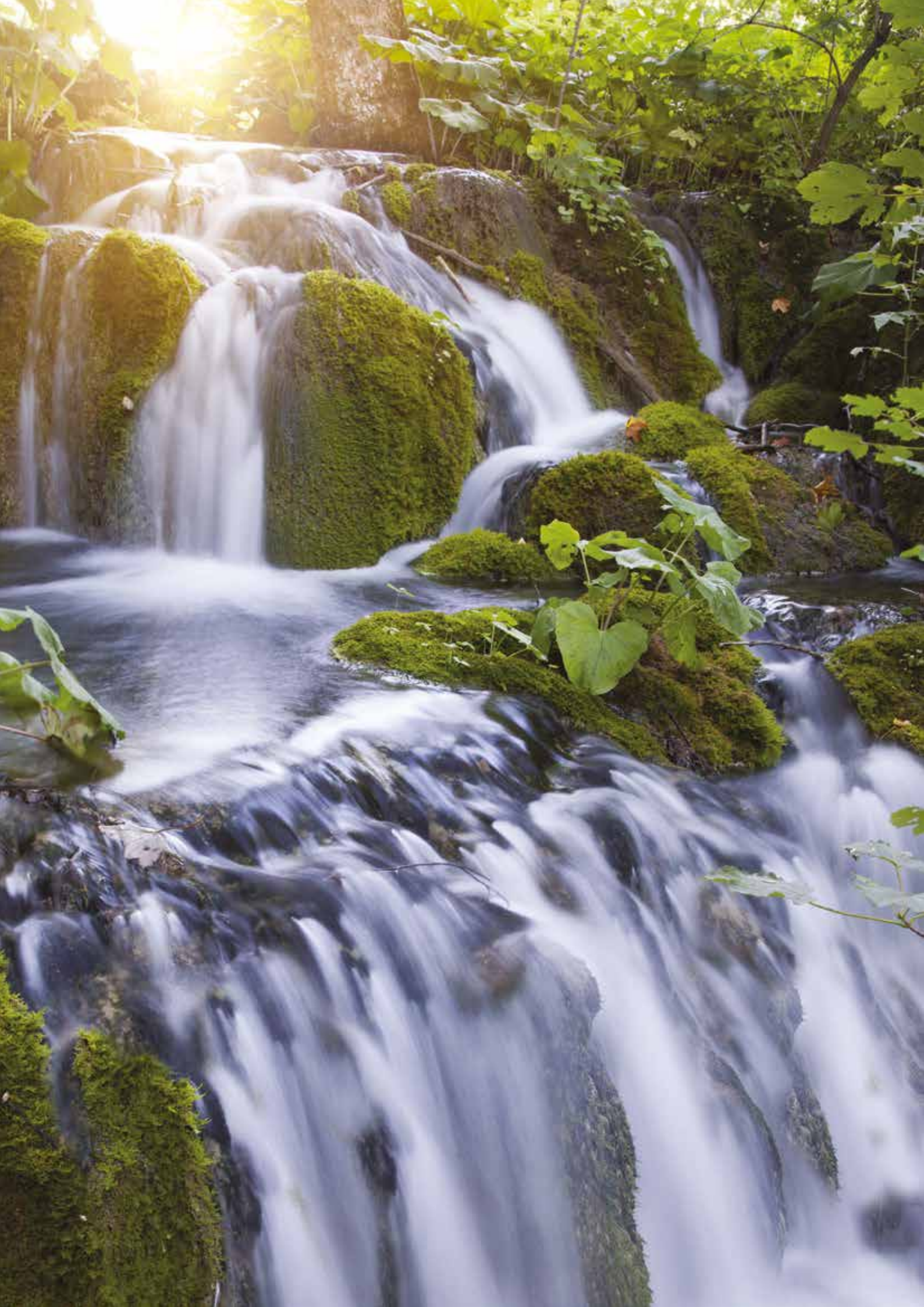



BENVENUTI IN CUCINA: UN LUOGO DI RELAZIONE DA VIVERE A 360°

welcome to the kitchen:
a place of relationship
to be, experienced at 360°

Uno spazio abitativo in continua evoluzione, fulcro della casa moderna. Un luogo non più solamente riservato alla preparazione dei piatti, ma multifunzionale, iperconnesso. Un punto di incontro, condivisione, convivialità, sperimentazione e in alcuni casi anche di lavoro. Uno spazio versatile all'insegna del comfort, della funzionalità e dell'estetica. Protagonista della vita quotidiana, è una delle stanze più inclini a riflettere i cambiamenti sociali a livello globale. Un ambiente per sua natura estremamente dinamico che si plasma sulle esigenze del vivere contemporaneo con la conseguente trasformazione degli elementi architettonici e degli arredi che la compongono in funzione della destinazione d'uso.

A continuously evolving living space, heart of the modern house. A multifunctional, hyperconnected place that is not only used for the preparation of meals. A meeting point, a sharing space of conviviality, experimentation and in some instances of work.

A versatile space dedicated to comfort, functionality and aesthetics. Protagonist of daily life, It is one of the rooms most prone to reflect social changes globally. A highly dynamic environment that is moulded to the needs of contemporary life, with the consequent transformation of the architectural elements and furnishings according to the intended use.

LIVING
KITCHEN



CROMO NEROBLACK CHROME
F7050CN

GALILEO

UNA RIVOLUZIONE
NELLA RUBINETTERIA
DA CUCINA

a revolution in the kitchen





F7050CS

GALILEOCOLORS



CROMO
CHROME
F7050CR



CROMO NERO
BLACK CHROME
F7050CN



CROMO NERO SPAZZOLATO
BRUSHED BLACK CHROME
F7050CS



BIANCO OPACO
WHITE MATT
F7050BS



NERO OPACO
BLACK MATT
F7050NS

Linee aerodinamiche e sfidanti il cui design si struttura in tre componenti principali che ne rendono funzionale l'uso quotidiano. Il corpo proiettato in avanti, è studiato per agevolare le operazioni in cucina e si adatta a ogni tipo di installazione e tipologia di lavello. L'ampia base, integrata nella parte bassa, contribuisce non solo all'estetica del prodotto, slanciandolo e donando eleganza, ma ne facilita il montaggio su qualsiasi piano. Cuore del miscelatore è il blocco di comando. Posizionato sulla parte alta della base, garantisce comodità di utilizzo in qualsiasi situazione quotidiana e conferisce leggerezza e pulizia formale. Al suo interno alloggia la manopola: semplificata all'estremo, si contraddistingue per lo stile raffinato e il look minimal e contemporaneo. In fase di installazione l'utente può decidere se configurarla con o senza il caratteristico pin in contrasto che permette, con un semplice gesto, di regolare il flusso e la temperatura dell'acqua, agevolando l'utente e minimizzando al contempo i consumi. Il doccino basculante è innestato lateralmente al blocco di comando attraverso un innovativo sistema magnetico, che consente anche di personalizzare in ogni momento l'inclinazione del getto. L'utente può così selezionare l'esatta posizione del doccino in ogni situazione adattando il prodotto all'esigenza contingente.

Aerodynamic and challenging lines whose design is structured in three main parts that make the daily use very functional the body is inclined forward to improve the performance and to allow Galileo to fit perfectly to every kind of installation and sink. The wider base enhances its elegance and allows for easier installation on all worktops. The core is the control center of the mixer. Positioned at the top of the base for easier use in everyday situations, it has a clean and elegant design. The handle, extremely simplified, gives a minimal and contemporary look with the option of a distinctive pin lever that is included in the packaging and can be easily added if consumers opt for it. The pin lever has the same finish as the flexible hose, a unique touch to every detail. The swivelling spout is attached to the side of the core by means of an innovative magnetic system that allows a comfortable and safe inclination of the spout. Depending on the size of the sink and on its depth, the spout can be positioned to the best inclination for the best performance. The flexible hose gives an extended mobility to the removable spout. Its length is fixed but it can vary and be set based upon the wishes and the needs of the consumer during installation, improving once again the performance and the comfort.

FIMA EDITION ONE



NERO OPACO/ROSSO
BLACK MATT/RED
F7050RNS



SKINNY

PERFETTA SINTESI
DI DESIGN,
INNOVAZIONE
E FUNZIONALITÀ

a perfect synthesis of design,
innovation and functionality



CROMOCHROME
F7026CR





EQUILIBRIO DI ESTETICHE MODERNE ED ERGONOMICHE ECCELLENTI

a perfect balance of modern
and ergonomic beauty

CROMO NEROBLACK CHROME
F7026CN

Espressione di un linguaggio progettuale evoluto Skinny è in grado di valorizzare qualsiasi cucina e integrarsi perfettamente con ogni stile, offrendo un equilibrio di estetiche moderne ed ergonomiche eccellenti. Il miscelatore si caratterizza per il suo corpo affusolato che si slancia elegantemente, collegando dolcemente il diametro della canna con la basetta integrata. Il morphing della superficie avviene così in modo asimmetrico delineando un profilo appiattito che permette l'innesto fluido del cilindro e conferisce al rubinetto un aspetto molto sottile e costante per tutta la sua altezza. Altro segno distintivo è la leva, reinterpretazione non convenzionale di una leva "forata" che si caratterizza per una maggiore ergonomia, che unisce una grande funzionalità di presa a un design elegante e pulito. Skinny monta una doccetta doppio getto per una massima funzionalità al servizio del quotidiano.

Expression of an advanced engineering development, Skinny is able to add value to any kitchen and to entirely fit in with every style, giving a perfect balance of modern and ergonomic beauty. The mixer is characterized by a slim body that gracefully soars, connecting smoothly the diameter of the spout with the integrated base. The morphing of its surface is asymmetrical, designing a flat shape that allows the fluid insertion of the cylinder and makes the mixer look thin and constant for its whole height. Another special feature is the lever, a new unconventional interpretation of a "perforated" lever that joins a greater functionality of an ergonomic grip to a clean and elegant design. Skinny integrates also a double jet handshower for maximum functionality in the daily use.



NERO OPACO
BLACK MATT
F7026NS

BIANCO OPACO
WHITE MATT
F7026BS

CROMO NERO SPAZZOLATO
BRUSHED BLACK CHROME
F7026CS

CROMO
CHROME
F7026CR



FLEXI

SCENOGRAFICHE ARCHITETTURE IN CUCINA

scenographic architectures in the kitchen



CROMO NEROBLACK CHROME
F7047CN





CROMO
CHROME
F7047CR



NICKEL SPAZZOLATO
BRUSHED NICKEL
F7047SN



CROMO NERO
BLACK CHROME
F7047CN



CROMO NERO SPAZZOLATO
BRUSHED BLACK CHROME
F7047CS

L'estetica pulita delle forme, che richiama architetture moderne, esaltata dalla sottigliezza della leva: questo il tratto distintivo della serie Flexi che si declina in 3 differenti modelli perfetti sia per agevolare le operazioni in zona lavello sia per valorizzare l'ambiente in cui sono inseriti.

Il modello F7047 si contraddistingue per la doccetta estraibile con molla di ritorno e per la canna girevole, che consentono di operare con facilità a 360 gradi. Grazie al flessibile in silicone disponibile in diversi colori e abbinabile al corpo del miscelatore, la doccetta si coordina perfettamente creando così un accattivante total look: grigio per le finiture cromo e nickel spazzolato, bianco per la finitura bianco opaco e nero per le finiture cromo nero, cromo nero spazzolato e nero opaco.

The clean aesthetics of the lines recalls modern architectures and it is enhanced by the thinness of the lever. This is the distinctive feature of Flexi. Flexi is available in 3 different versions, all of them perfect for facilitating the activities in the sink area and to enhance the design of the setting that they are integrated into.

F7047 is characterised by the pull down handshower with return spring and by the swivelling spout that allow an easy use at 360 degrees. The silicone flexible hose is available in different finishes with the purpose of matching with the body mixer and the handshower: grey for the body finishes chrome and brushed nickel, white for matt white body, black for matt black, black chrome, brushed black chrome bodies, creating in this way an eye catching total look.



BIANCO OPACO
WHITE MATT
F7047BS



NERO OPACO
BLACK MATT
F7047NS

FLEXI



CROMO NERO SPAZZOLATO BRUSHED BLACK CHROME
F7047/1SN



DESIGN ELEGANTE
ED ERGONOMICO,
STUDIATO PER
INCONTRARE
MOLTEPLICI ESIGENZE
FUNZIONALI E
SODDISFARE I GUSTI
DEL CONSUMATORE
CONTEMPORANEO

elegant and ergonomic design,
conceived to meet many functional
needs and to satisfy the expectations
of the contemporary consumer

A livello estetico Flexi F7047/1 si caratterizza per linee più dinamiche sia per il design del braccio del miscelatore che per il tubo a molla, mentre Flexi F7047/2 rompe la linearità di Flexi F7047 con un'inclinazione del braccio del miscelatore. ed è disponibile con tubo in silicone nero. Il plus di entrambi risiede nei due differenti getti - aeratore e spray - della doccetta estraibile, che permettono di scegliere con facilità e rapidità il tipo di flusso, in base alle esigenze del momento in cucina. Entrambi sono disponibili in quattro finiture: cromo, nickel spazzolato, bianco opaco e nero opaco.

Flexi F7047/1 features more dynamic lines, thanks to the design of the handshower bracket and of the sprung tube. While Flexi F7047/2 breaks the linearity of Flexi F7047 with an inclination of the handshower bracket and it is available with black silicone hose. Their plus lies in the two different jets function of the pull-down handshower - aerator and spray -, which allow to easily and quickly choose the type of flow, based upon the needs. Both are available in four finishes: chrome, brushed nickel, matt white and matt black.

FLEXI



CROMO NERO SPAZZOLATO BRUSHED BLACK CHROME
F7047/2SN

L'ESTETICA
PULITA
DELLE FORME
VIENE ESALTATA
DALLA
SOTTIGLIEZZA
DELLA LEVA

The clean aesthetics of
the shapes is enhanced
by the minimal lever



BIANCO OPACO
WHITE MATT
F7047/2BS



NERO OPACO
BLACK MATT
F7047/2NS



CROMO
CHROME
F7047/2CR

AISI 304

STEEL



F7057INOX

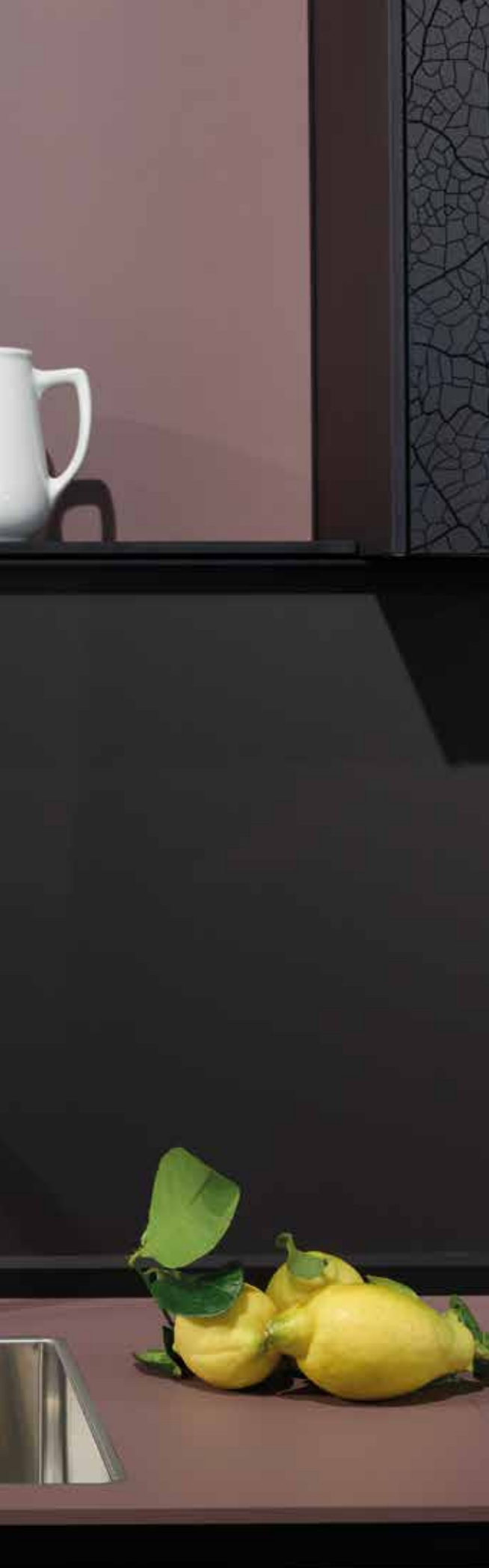

STILE SENZA TEMPO E UN MATERIALE DALL'ANIMA GREEN: IN UNA PAROLA STEEL

a product that combines a timeless style with essential green materials

Steel è realizzato interamente in acciaio inox, un materiale che ha conquistato una propria identità nel settore grazie alle sue proprietà intrinseche di inalterabilità nel tempo, igienicità ed eco-sostenibilità. La resistenza alla corrosione e la durezza del materiale rappresentano la garanzia di qualità della serie e ne assicurano la durata nel tempo grazie a un'inerzia nei confronti degli agenti esterni e alla resistenza all'azione di detersivi e solventi, rendendola anche igienica e facile da pulire. Oltre a una naturale inalterabilità alle sollecitazioni, l'acciaio inox non contiene metalli nocivi, non necessita di verniciature o rivestimenti superficiali dannosi per l'ambiente, è atossico e riciclabile. Per tutte queste peculiarità è ideale per la realizzazione di rubinetti che sposano le esigenze di design con le normative vigenti in tema di sicurezza per la salute e l'ambiente.



The perfect combination between design and environmental sustainability, a product that combines a timeless style with essential green materials. The stainless steel has acquired its own identity in the industry thanks to its intrinsic features of inalterability over time, cleanliness and environmental friendliness. Corrosion resistance and material hardness represent the guarantee of quality of the series and ensure it is long-lasting, thanks to its endurance towards external agents and its resistance to detergents and solvents, making it hygienic and easy to clean. In addition to its natural inalterability to stresses, stainless steel does not contain toxic metals, does not need any environmentally harmful surface coatings and it is recyclable. Thanks to all these unique qualities it is suitable for manufacturing taps that combine in a perfect balance the need for design with the existing safety legislation for health and environment.



L'ECCELLENZA
DELL'ACCIAIO
INOX E
UN DESIGN
ESSENZIALE

the supremacy of stainless
steel and an essential design

F7057INOX



F7024INOX



F7025INOX

NOMOS



CROMO
CHROME
F7107CR



CROMO
CHROME
F7117CR

MIRABILE SINTESI TRA FORMA E FUNZIONE PER LA CUCINA

An admirable combination
of function and style for the kitchen

Dalla passione per l'innovazione e la sperimentazione nasce un miscelatore dalle linee eleganti e raffinate improntate ai canoni del minimalismo, capace di adattarsi perfettamente alla cucina contemporanea. Con Nomos, lavorando su estetica e funzionalità, si compiono evoluzioni stilistiche e tecnologiche in cui il design dei componenti è sempre più ricercato ed è ben visibile la particolare incisività delle forme quasi scultoree. Numerose le versioni disponibili per garantire la massima personalizzazione stilistica e formale nell'ambiente cucina: con doccetta e flessibile estraibile, con bocca piatta, con bocca cilindrica. Una soluzione che garantisce massima praticità nella gestione quotidiana del lavoro in cucina.

Born from the passion for innovation and for experimentation Nomos is a mixer with elegant and refined lines based on minimalistic concepts that fits perfectly into the contemporary kitchen. Working on aesthetics and functionality, stylistic and technological evolutions are carried out, the design of the components is more refined and the incisiveness of the almost sculptural forms is clearly visible. There is a wide choice available to ensure maximum stylistic and formal customization in the kitchen environment: with pull down handshower, with flat or cylindrical spout. A solution that guarantees great functionality in the daily use.



F7097CR



BIANCO WHITE
F7028BS

FLUID

DINAMISMO
E CONTINUITÀ DI
FORME IN CUCINA

the harmony of flowing
shapes in motion in the kitchen





NERO BLACK
F7028NS



BIANCO WHITE
F7028BS

UN DESIGN CINETICO E PLASTICO, LINEE FLUIDE IN ARMONIA CON LO SPAZIO

a kinetic and plastic
design, fluid lines in
harmony with space

Continuità di forme dinamiche in totale armonia con lo spazio: ecco i plus di Fluid, emblema perfetto della fusione di linee sinuose che si allungano e si disegnano in un continuum progettuale di grande fluidità. Una soluzione unica che combina design, funzionalità ed estetica innovativa, premiata con il prestigioso riconoscimento Design Plus 2011.

Gli elementi di Fluid emergono in maniera plastica dalla base, punto nevralgico da cui si sviluppa un dinamismo sinuoso che accarezza l'intero profilo del miscelatore. Tutte le sue componenti sono progettate per esprimere visivamente il concetto di movimento. Canna e mixer cilindrici si elevano dalla base verso l'alto e si collocano nello spazio con grazia ed equilibrio. Un design cinetico sul layout permette di alloggiare la cartuccia sopra il livello del piano lavabo, e di allineare così la canna del miscelatore sul foro del lavello. Fluid è dotato di bocca con doccetta estraibile per assicurare la massima praticità in cucina.

The harmony of shapes in motion that create sleek lines in the setting: this is the unique feature of Fluid, whose graceful design where supple flowing lines mix and match is a perfect example of harmony. This product was awarded the renowned Design Plus 2011 prize in recognition of its uniqueness, combining design, innovative look and functional effectiveness.

All Fluid components plastically arise from the base, which is the starting point for the development of supple flowing lines gracefully stroking the mixer tap profile. Their design is based on the concept of movement, which the product perfectly embodies. The cylinder-shaped spout and mixer tap gracefully arise from the base in perfect balance with the setting. A dynamic layout design allows housing the cartridge above the washbasin level, thus having the mixer tap spout flush with the washbasin hole. This product is equipped with a handy pullout faucet which is essential in the busy kitchen.



SWING



CROMO CHROME
F7027CR

ESTETICA E FUNZIONALITÀ ESTREMA AL SERVIZIO DELLA CUCINA

aesthetics and extreme
functionality at the service
of the kitchen

A livello formale Swing è diviso in due parti da una superficie piana parallela al lavabo: la parte inferiore è composta da superfici morbide che si raccordano e terminano sulle due circonferenze della base e dell'aeratore; la parte superiore comprende gli elementi tecnici a vista: il joystick, il flessibile e la molla. Un chiaro riferimento al mondo delle grandi cucine professionali dove protagoniste sono la funzionalità e la facilità d'uso. Swing è un miscelatore da cucina costituito da un corpo fuso centrale che integra cartuccia e sostegno per la doccetta. La cartuccia è allineata al foro del lavabo e costringe l'uscita dell'acqua miscelata posteriormente, creando il gozzo che ne caratterizza il design. Il flessibile è collocato accanto al joystick, sormontandolo per creare uno scenografico arco che si collega frontalmente al corpo con la doccetta.

Outwardly, this tap is divided into two sections by the flat surface parallel to the sink: the lower section consists of soft harmonically-linked surfaces ending with the two circles at the base and at the aerator; the upper section comprises the visible technical elements, including the joystick lever, the extendable hose and the spring. A clear nod towards the world of professional kitchens where functionality and ease of use are the protagonists. Swing is a kitchen mixer comprising a cast central body equipped with cartridge and spray head holder. The cartridge is aligned with the sink hole, forcing the mixed water to exit at the back, thus forming the distinctive enlargement that characterises its shape. The extendable hose is located next to the joystick lever and arches above it to re-connect to the body at the front with the spray head.





UP

CROMO CHROME
F7037CR

GHOST

SOLUZIONE SALVASPAZIO PER L'AMBIENTE CUCINA

space-saving solution for the kitchen

Un miscelatore monocomando dallo stile minimal dotato di sistema abbattibile push/pull: con un semplice gesto la canna si abbassa fino a scomparire completamente nel piano. Una soluzione evoluta sia per l'installazione sotto-finestra, sia per l'abbinamento con gli ultimi modelli di lavelli che possono essere integrati nei top e utilizzati come superfici continue di appoggio e di lavoro. Un prodotto che offre un vantaggio pratico, il senso di ordine e di pulizia all'intera cucina, oltre che un piacevole aspetto estetico grazie allo stile minimal delle forme.

The minimal single lever mixer equipped with an up and down foldable system, with a simple pressure the spout can be lowered until it completely disappears from the top. An advanced solution both for under-window installation and for combining with the latest models of sinks, where by mean of built-in tops they can be covered and used as additional work surfaces. A single-lever mixer that offers a practical advantage, a sense of order and cleanliness to the entire kitchen, as well as a pleasant look thanks to its minimal lines.

DOWN



SETTANTA29



CROMO
CHROME
F7029NOTCR



NICKEL SPAZZOLATO
BRUSHED NICKEL
F7029NOTSN



CROMO NERO
BLACK CHROME
F7029NOTCN



CROMO NERO SPAZZOLATO
BRUSHED BLACK CHROME
F7029NOTCN



BIANCO OPACO
WHITE MATT
F7029NOTBS



NERO OPACO
BLACK MATT
F7029NOTNS



BRONZO
BRONZE
F7029NOTBR



RAME ANTICO
OLD COPPER
F7029NOTRA

SETTANTA 29

UN'AMPIA PALETTE DI FINITURE PER PERSONALIZZARE CON STILE LA CUCINA

a wide options offinishes to
personalize the kitchen with style

Pratico e funzionale il miscelatore da cucina SETTANTA29, si caratterizza per l'estetica rigorosa ma rifinita da angoli morbidi. È dotato di doccia estraibile e canna girevole per convogliare l'acqua dove ce n'è bisogno. Personalizzabile con un'ampia gamma di finiture, si trasforma così da elemento prettamente funzionale a oggetto protagonista dell'ambiente in cui si inserisce. Una soluzione ideale che coniuga elevata ricerca tecnologica, estetica accattivante e un ottimo rapporto qualità - prezzo.

SETTANTA29 kitchen mixer tap is practical and functional and it has a rigorous aesthetics softened by rounded corners. It is equipped with a pull out handshower and with a swivelling spout, to reach all sink areas. Customizable thanks to a wide range of finishes, it transforms itself from a purely functional element into a protagonist. An ideal solution that combines high technological research, captivating aesthetics and an excellent quality - price ratio.





BIANCO WHITE
F7029NOTBS

MAST



CROMO CHROME
F3147/1CR

Mast, il miscelatore monocomando sfaccettato ed elegante, si contraddistingue per la varietà di forme del profilo studiate per soddisfare le diverse esigenze di stile dell'ambiente cucina. Un prodotto che diventa un'insostituibile strumento non solo in quanto contribuisce a connotare la cucina con un appeal di design ma anche perché svolge un ruolo preciso: garantire efficienza nella zona lavaggio. E' stato infatti progettato per essere utilizzato con grande praticità nei gesti quotidiani del lavaggio e della preparazione dei cibi, orientando e spostando il flusso dove è necessario.

Mast, the multifaceted and elegant single-lever mixer, is characterized by its variety of profile shapes designed to meet the different styles of the kitchen environment. A product that becomes an irreplaceable tool, as it contributes to give a design appeal to the kitchen and plays a precise role: it ensures efficiency in the sink area. It is in fact designed to be used with great functionality in the daily work of washing and preparing meals, directing the flow where needed.

UN PERFETTO
EQUILIBRO
TRA FORME E
FUNZIONALITA'

a perfect balance between
shapes and functionality





UN SOLO NOME,
UN'AMPIA GAMMA
DI POSSIBILITA'

one name,
a wide range of choices

CROMO CHROME
F3538NCR



CROMO CHROME
F3137/3CR



CROMO CHROME
F3137/1CR

SPIILLO



NERO BLACK
F3227NS



FORME GEOMETRICAMENTE PERFETTE PER UN DESIGN INCISIVO

geometrically perfect forms for a
rational, incisive and effective design

Un profilo accattivante caratterizzato da volumi leggeri e linee essenziali, ideali per conferire un tocco personale al look della cucina. Queste le peculiarità di Spillo, le cui forme slanciate si fondono in un disegno dal linguaggio minimalista, rendendo la collezione adattabile e versatile a diversi contesti residenziali. Un design assolutamente lineare e pulito che sembra plasmare lo scorrere continuo dell'acqua migliorando la prestazione del miscelatore in termini di erogazione per rendere la zona lavaggio una postazione sempre più efficiente.

An appealing profile characterized by light volumes and essential lines, ideal for giving a personal touch to the kitchen, Slendershapes merge into a minimalistic design, making Spillo suitable and versatile to different residential contexts.

A perfect linear and clean design that appears to shape the flow of the water, improving its performance and making the washing area a more efficient workstation.



CROMO CHROME
F3067/1CR



CROMO CHROME
F5087CR

CLASSICI

IL FASCINO DELLE
FORME DALL'ANIMA
CLASSICA

the charm of shapes with
classic souls conquers
traditional and modern kitchens



FORME DI CLASSICA ELEGANZA, ESPRESSIONE DI MOLTEPLICI STILI

shapes of classic elegance,
expression of many styles



CROMO CHROME
F3367CR



BRONZO BRONZE
F5087BR



RAME ANTICO OLD COPPER
F5417NRA



BRONZO BRONZE
F7030BR

RAFFINATEZZA ED ELEGANZA PER OGNI AMBIENTE

refinement and elegance
for every kitchen



Ampiezza e trasversalità, queste le caratteristiche vincenti delle serie Classici che comprendono miscelatori in stile retrò dalle forme sinuose realizzati in svariate finiture. Ideali per arredare cucine di ispirazione classica per coerenza estetica, rappresentano una scelta interessante anche per contesti più moderni in cui non si vuole rinunciare alla tradizione. I modelli new classic, grazie alle particolari linee che rievocano il passato reinterpretandolo in chiave moderna, donano alla cucina un raffinato tocco decorativo, portando armonia delle proporzioni. Oltre allo specifico design che contraddistingue ciascun modello, le manopole ne rappresentano una particolarità: la gamma si compone di proposte sia dal gusto minimalista sia più elaborate, impreziosite da componenti decorativi in ceramica o cristallo che le rendono di grande effetto.

Breadth and transversality of the offer are the winning features of Classici Collection that includes Retro-style mixers with sinuous shapes in different finishes. Ideal for classical kitchens, they fit even in modern contexts for those who don't want to give up the traditional touch. The new classic models, whose lines evoke the past, are reinterpreted with a modern view and they give the kitchen a refined decorative touch of harmonic proportions. In addition to the specific design that characterizes each model, the knobs give an additional distinction offering both minimalistic and more elaborated options, embellished with decorative ceramic or crystal components that make them highly attractive.





SCOPRI LA
GAMMA COMPLETA

DISCOVER THE COMPLETE RANGE

Miscelatore lavello con canna girevole e doccetta estraibile 2 getti (tubo in silicone in colore nero)
 Kitchen mixer with swivel spout and 2 jets extractable handshower (black silicone flexible)

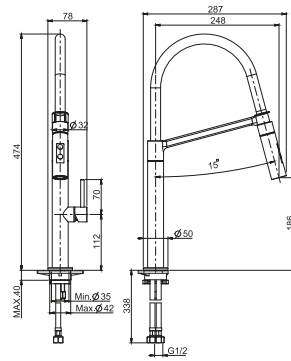

-  F7047/2CR
-  F7047/2SN
-  F7047/2BS
-  F7047/2NS

FLEXI

Miscelatore lavello in acciaio inox con canna girevole
 Stainless steel kitchen mixer with swivel spout

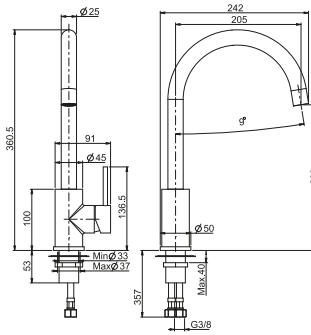

-  WATER SAVING CARTRIDGE
-  F7057INOX

STEEL

Miscelatore lavello in acciaio inox con canna girevole
 Stainless steel kitchen mixer with swivel spout

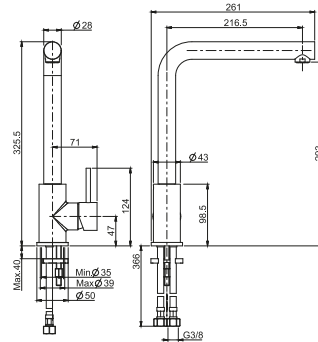

-  WATER SAVING CARTRIDGE
-  F7024INOX

STEEL

Miscelatore lavello in acciaio inox con canna girevole e doccetta estraibile
 Stainless steel kitchen mixer with swivel spout and extractable handshower

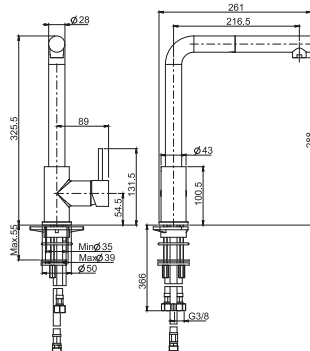

-  WATER SAVING CARTRIDGE
-  F7025INOX

STEEL

KITCHEN COLLECTION

Miscelatore lavello con canna girevole e doccetta estraibile
Kitchen mixer with swivel spout and extractable handshower

NOMOS

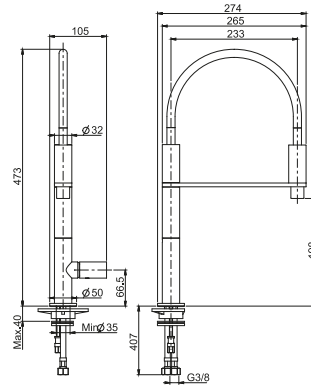

Miscelatore lavello con canna girevole
Kitchen mixer with swivel spout

NOMOS

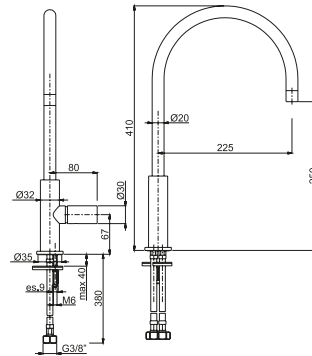

Miscelatore lavello con canna girevole
Kitchen mixer with swivel spout

NOMOS

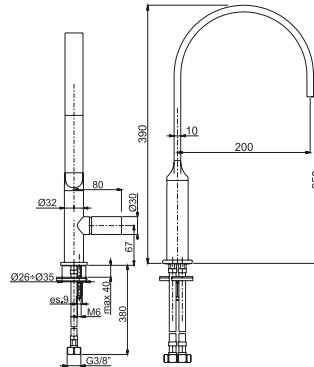

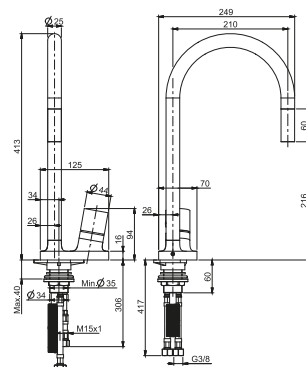

Miscelatore lavello con canna girevole e doccetta estraibile 2 getti
Kitchen mixer with swivel spout and 2 jets extractable handshower

FLUID

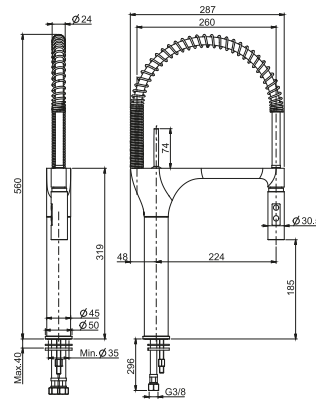

Miscelatore lavello con canna girevole e doccetta estraibile 2 getti
 Kitchen mixer with swivel spout and 2 jets extractable handshower



-  F7027CR
-  F7027SN

SWING

Miscelatore lavello con canna abbattibile e comando remoto
 Kitchen mixer with pull/down spout and remote control

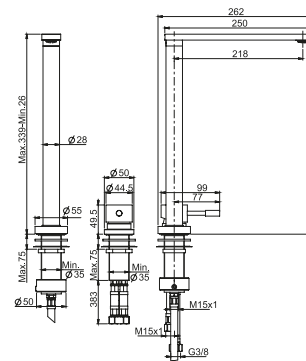

-  F7037CR

GHOST

Miscelatore lavello con canna girevole e doccetta estraibile
 Kitchen mixer with swivel spout and extractable handshower

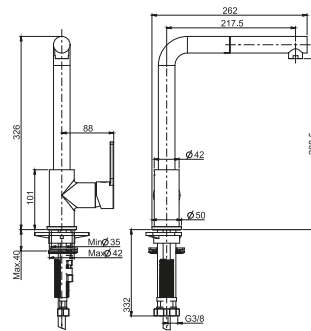

-  F7029NOTCR
-  F7029NOTSN
-  F7029NOTCN
-  F7029NOTCS
-  F7029NOTBS
-  F7029NOTNS
-  F7029NOTBR
-  F7029NOTRA

SETTANTA29



Miscelatore lavello con canna girevole e doccetta estraibile in ottone 2 getti
 Kitchen mixer with swivel spout and 2 jets brass extractable handshower

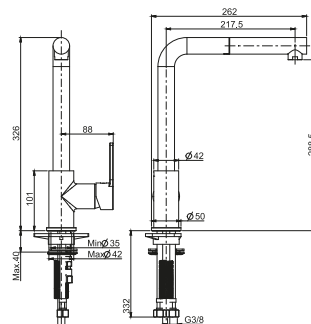

-  ENERGY SAVING CARTRIDGE F7029NCR

SETTANTA29

KITCHEN COLLECTION

Miscelatore lavello con canna girevole e doccetta estraibile 2 getti
Kitchen mixer with swivel spout and 2 jets extractable handshower

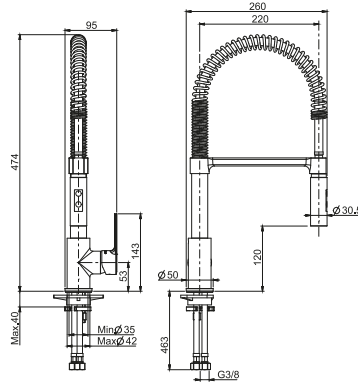

-  F3147/1CR
-  F3147/1SN
-  F3147/1CN
-  F3147/1CS
-  F3147/1BS
-  F3147/1NS
-  F3147/1BR
-  F3147/1RA

MAST

Miscelatore lavello con canna girevole e doccetta estraibile 2 getti
Kitchen mixer with swivel spout and 2 jets extractable handshower

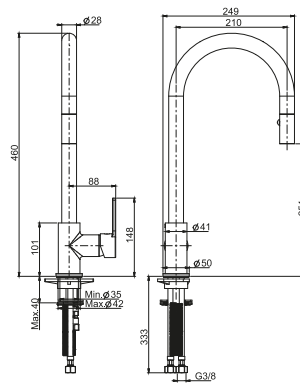



ENERGY SAVING CARTRIDGE
F3538NCR

MAST

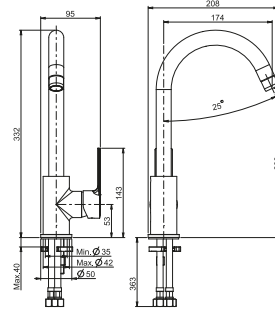
Miscelatore lavello con canna girevole
Kitchen mixer with swivel spout





-  F3137/3CR
-  F3137/3SN
-  F3137/3CN
-  F3137/3CS
-  F3137/3BS
-  F3137/3NS
-  F3137/3BR
-  F3137/3RA

ENERGY SAVING CARTRIDGE

MAST

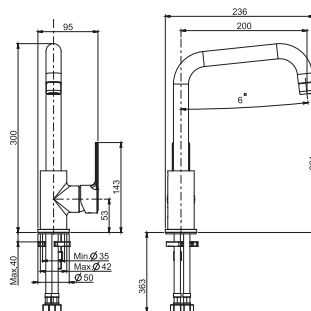
Miscelatore lavello con canna girevole
Kitchen mixer with swivel spout



-  F3137/1CR
-  F3137/1SN
-  F3137/1CN
-  F3137/1CS
-  F3137/1BS
-  F3137/1NS
-  F3137/1BR
-  F3137/1RA

ENERGY SAVING CARTRIDGE

MAST

Miscelatore lavello con canna girevole
Kitchen mixer with swivel spout

SPILO UP

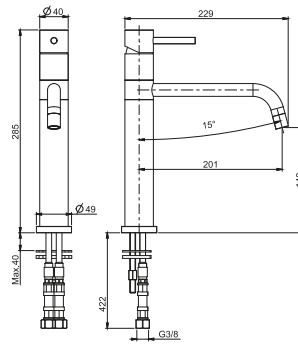

-  F3227CR
-  F3227SN
-  F3227BS
-  F3227NS

Miscelatore lavello con canna abbattibile e girevole
Kitchen mixer with pull/down spout and swivel spout

SPILO UP

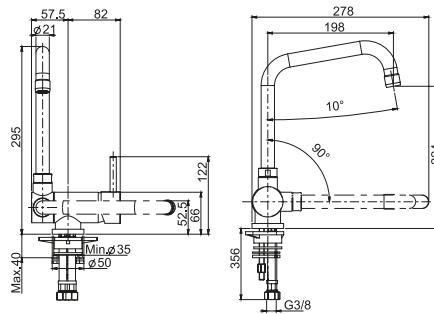

-  F7009CR

Miscelatore lavello con canna girevole
Kitchen mixer with swivel spout

SPILO UP

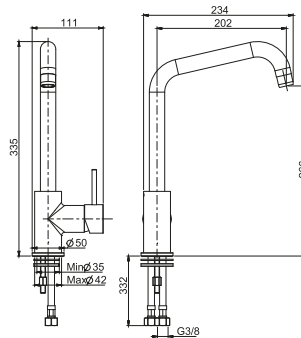

-  F3067/1RCR
-  F3067/1RSN
-  F3067/1RCN
-  F3067/1RCS
-  F3067/1RBS
-  F3067/1RNS
-  F3067/1RBR
-  F3067/1RRA

Miscelatore lavello con canna girevole
Kitchen mixer with swivel spout

SPILO UP

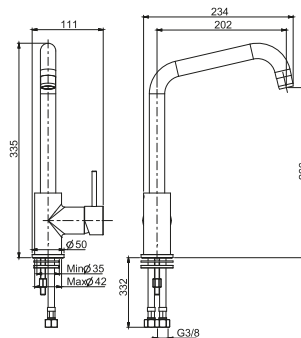

-  F3067/1RCR.ES
-  F3067/1RSN.ES
-  F3067/1RCN.ES
-  F3067/1RCS.ES
-  F3067/1RBS.ES
-  F3067/1RNS.ES
-  F3067/1RBR.ES
-  F3067/1RRA.ES



KITCHEN COLLECTION

Miscelatore lavello con canna girevole e doccetta estraibile 2 getti
Kitchen mixer with swivel spout and 2 jets extractable handshower

CLASSICI

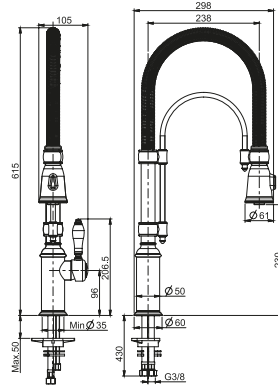

-  F7030CR
-  F7030SN
-  F7030BR
-  F7030RA

Monoforo lavello con canna girevole
Kitchen mixer with swivel spout

CLASSICI OLIVIA

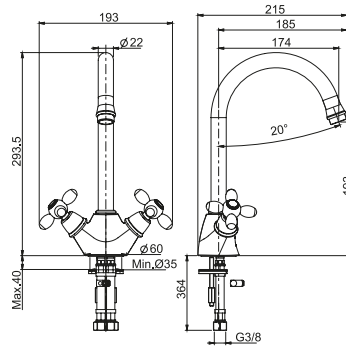

-  F5007CR
-  F5007SN
-  F5007OR
-  F5007BR
-  F5007RA

Monoforo lavello con canna girevole
Kitchen mixer with swivel spout

CLASSICI ELIZABETH

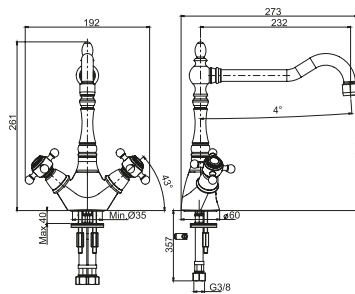

-  F5087CR
-  F5087SN
-  F5087OR
-  F5087BR
-  F5087RA

Miscelatore lavello con canna girevole
Kitchen mixer with swivel spout

CLASSICI BELL

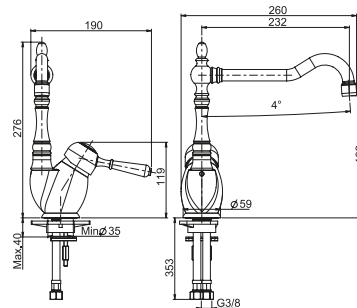



-  F3367CR
-  F3367SN
-  F3367OR
-  F3367BR
-  F3367RA

KITCHEN COLLECTION

Miscelatore lavello con canna girevole
e doccetta estraibile in ottone 2 getti
Kitchen mixer with swivel spout and
2 jets brass extractable handshower

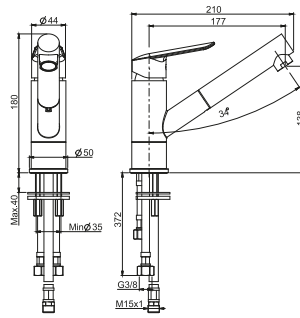
SPOT



-  **F3008CR**
-  **F3008CR.WS**
-  **F3008CR.ES**

Miscelatore lavello con canna girevole
Kitchen mixer with swivel spout

SPOT

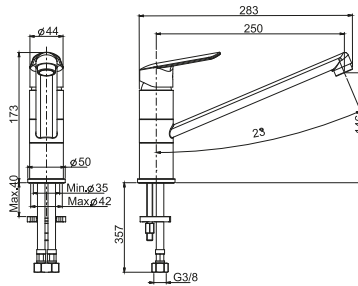

-  **F3007CR**
-  **F3007CR.WS**
-  **F3007CR.ES**

Miscelatore lavello con canna girevole
Kitchen mixer with swivel spout

SPOT

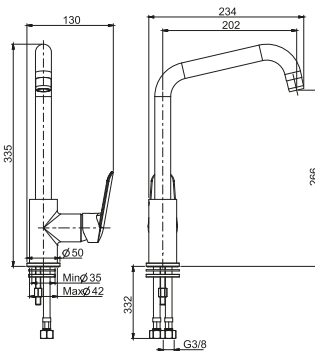



-  **F3007/1RCR**
-  **F3007/1RCR.ES**

Miscelatore lavello con canna girevole
e doccetta estraibile
Kitchen mixer with swivel spout and
extractable handshower

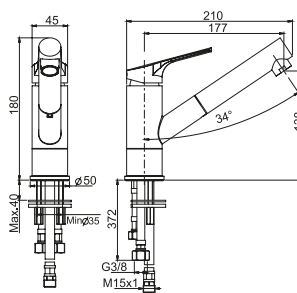
SERIE 4



-  **F3768CR**
-  **F3768CR.WS**
-  **F3768CR.ES**

Monoforo lavello con canna girevole
Kitchen mixer with swivel spout

SERIE 4

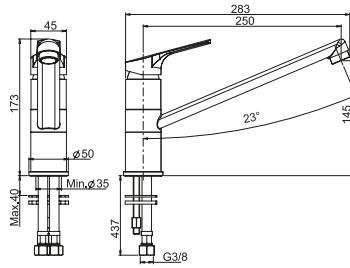

F3797CR

WATER SAVING CARTRIDGE
F3797CR.WS

ENERGY SAVING CARTRIDGE
F3797CR.ES

Miscelatore lavello con canna girevole
Kitchen mixer with swivel spout

SERIE 4

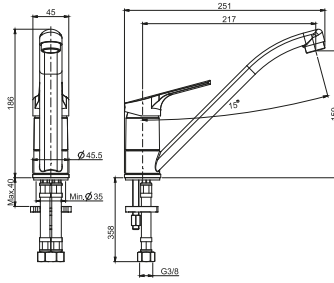

F3767CR

WATER SAVING CARTRIDGE
F3767CR.WS

ENERGY SAVING CARTRIDGE
F3767CR.ES

Miscelatore lavello con canna girevole
Kitchen mixer with swivel spout

SERIE 4

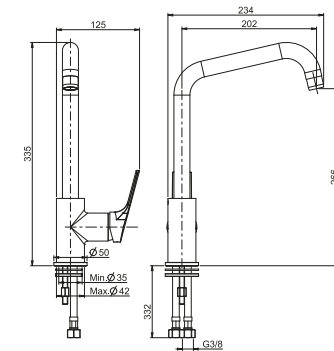

F3767/1RCR

ENERGY SAVING CARTRIDGE
F3767/1RCR.ES

Miscelatore lavello con canna girevole
Kitchen mixer with swivel spout

SERIE 4

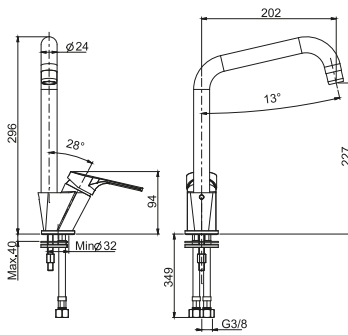

F3797/1CR

WATER SAVING CARTRIDGE
F3797/1CR.WS



ENERGY SAVING CARTRIDGE
F3797/1CR.ES

KITCHEN COLLECTION

Miscelatore lavello con canna girevole
Kitchen mixer with swivel spout

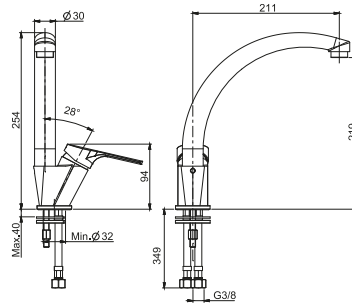
SERIE 4



-  **F3797/2CR**
-  **F3797/2CR.WS**
-  **F3797/2CR.ES**

Monoforo a parete con canna girevole
Wall kitchen mixer with swivel spout

SERIE 4

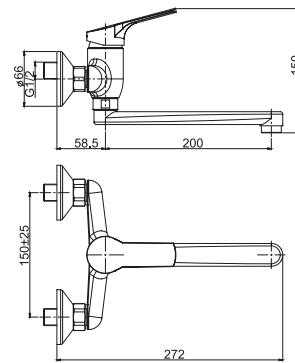

-  **F3766CR**
-  **F3766CR.ES**

Miscelatore lavello con canna girevole
e doccetta estraibile
Kitchen mixer with swivel spout and
brass extractable handshower

SERIE 22

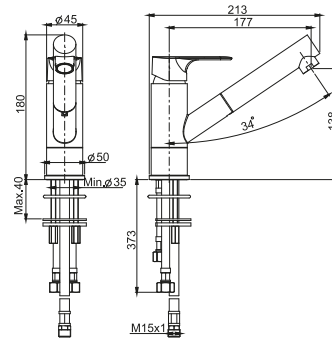

-  **F3838CR**
-  **F3838CR.ES**

Monoforo lavello con canna girevole
Kitchen mixer with swivel spout

SERIE 22

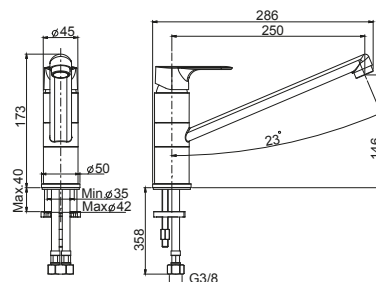

-  **F3897CR**
-  **F3897CR.ES**

Monoforo lavello con canna girevole
Kitchen mixer with swivel spout

SERIE 22

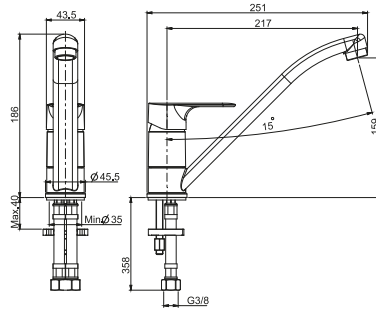

WATER SAVING CARTRIDGE
F3837CR

ENERGY SAVING CARTRIDGE
F3837CR.ES

Miscelatore lavello con canna girevole
Kitchen mixer with swivel spout

SERIE 22

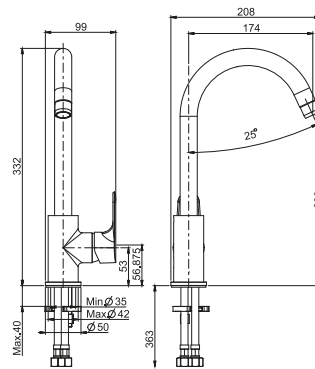

ENERGY SAVING CARTRIDGE
F3837/3CR

Monoforo lavello con canna girevole
Kitchen mixer with swivel spout

SERIE 22

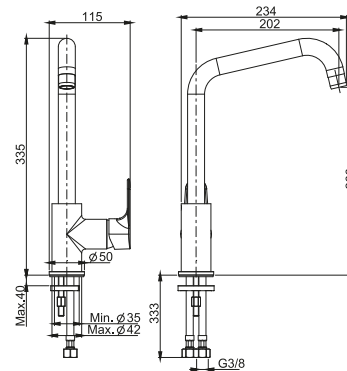

F3837/1CR

Monoforo lavello con canna girevole
Kitchen mixer with swivel spout

SERIE 22

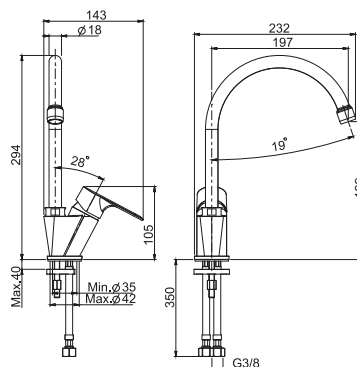

WATER SAVING CARTRIDGE
F3897/1CR

ENERGY SAVING CARTRIDGE
F3897/1CR.ES

KITCHEN COLLECTION

Monoforo lavello con canna girevole
Kitchen mixer with swivel spout

SERIE 22

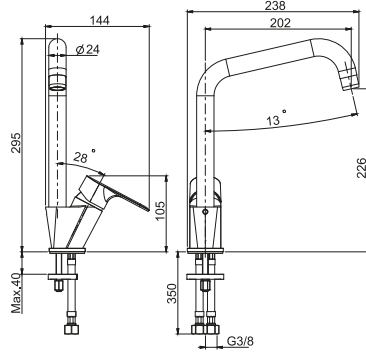

- 
WATER SAVING
F3847/1CR
- 
ENERGY SAVING
F3847/1CR.ES

Monoforo lavello con canna girevole
Kitchen mixer with swivel spout

SERIE 22

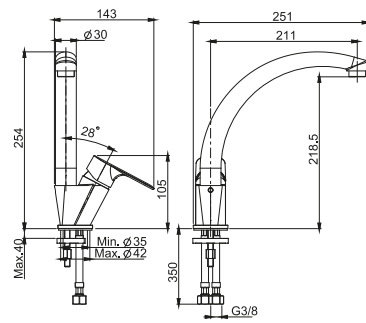

- 
WATER SAVING
F3847/2CR
- 
ENERGY SAVING
F3847/2CR.ES

Monoforo lavello con canna girevole
Kitchen mixer with swivel spout

SERIE 22

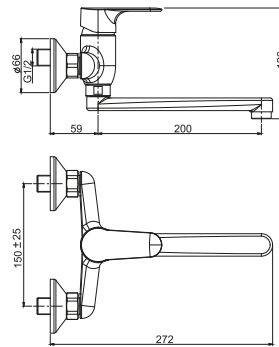

- 
WATER SAVING
F3836CR
- 
ENERGY SAVING
F3836CR.ES

THE COMPLETE COMPANY COLLECTION



life



LIVE FOR TODAY
IMAGINE NEW ADVENTURES
FIND YOUR HAPPINESS
ENJOY YOUR LIFE

INDEX

06	COMPANY
08	#GREEN#QUALITY#DESIGN
10	FINISHING
12	SO
26	TEXTURE COLLECTION
38	ECLIPSE
48	NOMOS GO
58	FLUID
68	DESOTO
78	NEXT
88	ZETA
98	QUAD
108	SPILOTECH
116	SPILOUP
126	SPILOSTEEL
130	MAST
140	MAXIMA
150	SPOT
160	SERIE4
170	FIMABOXES

#COMPANY

Tecnologia, estetica ed elevate prestazioni: FIMA Carlo Frattini propone da oltre 50 anni rubinetteria di altissima qualità destinata a durare nel tempo e capace di dare valore aggiunto ad ogni progetto. L'Azienda ha assunto negli anni un taglio innovativo ed in continua evoluzione, grazie alla creatività, al design e alle nuove tecnologie, che differenziano le sue collezioni. FIMA, infatti, si rinnova costantemente, come dimostrano l'alto livello progettuale e qualitativo della produzione, i continui investimenti in ricerca, la forte espansione nazionale e internazionale, la professionalità del team aziendale. Questo atteggiamento ha portato l'Azienda ad interpretare e anticipare le esigenze contemporanee e future del mercato, proponendo prodotti all'avanguardia per design e tecnologia, curati singolarmente in ogni dettaglio.

Technology, aesthetics and performance: FIMA Carlo Frattini has been offering for more than 50 years high quality faucets designed to last over time and able to give added value to each project. Over the years the Company has taken an innovative and evolving feature, thanks to its creativity, design and new technologies, which differentiate its collections from others. FIMA, in fact, is being continually upgraded by way of its high level of design, quality of production, continuous investments in research, the strong national and international expansion and the professionalism of the corporate team. This attitude has led the company to understand and anticipate the contemporary and future market needs by offering technically and esthetically advanced products, which are treated individually in every detail.



fima | CARLO FRATTINI
CONSTRUTTORE



#GREEN

FIMA CARLO FRATTINI da anni evolve i propri processi produttivi finalizzandoli ad una costante riduzione di risorse, materiali ed energia ed operando un controllo costante sulle materie prime, sui consumi e sull'impatto ambientale di tutte le fasi di produzione e commercializzazione dei propri prodotti.

Un'azienda eco sostenibile, alimentata da energia auto-prodotta e in grado di realizzare prodotti sicuri per la salute e per l'ambiente con un basso impatto ambientale.

FIMA CARLO FRATTINI has been for many years constantly developing its production processes in order to reduce the use of resources, materials and energy. Furthermore, all FIMA Carlo Frattini projects are developed considering all the steps of a product's life, from its manufacturing to the shipment till its dismantlement.

An environmentally friendly company, powered by self-produced electricity and able to produce products safe for human health and the environment with a very low environmental impact.

#QUALITY

I migliori materiali e tecnologie all'avanguardia per garantire un utilizzo quotidiano impassibile al trascorrere del tempo. Fima Carlo Frattini sposa un approccio globale alla qualità che deriva da un'attenzione all'innovazione tecnologica, adottando processi industriali all'avanguardia, scegliendo le migliori materie prime. Tutti i prodotti vengono sottoposti a minuziosi e severi controlli in ogni fase di lavorazione e sono progettati in modo da rispettare tutte le più rigide normative internazionali. Ulteriore testimonianza di questa filosofia improntata alla qualità totale è la garanzia che si estende per ben 7 anni su tutta la produzione.

Best materials and cutting-edge technologies as a guarantee for an everyday use unchanging over time. FIMA Carlo Frattini follows a global approach to quality coming from a particular attention to technology innovation, by adopting cutting-edge industrial processes, choosing the best raw materials. Detailed strict controls are carried out on all the products in every production phase and all the items are designed in order to respect the most stringent international regulations. Its seven-year extended warranty on all the product is a further evidence of this philosophy based on total quality.

#DESIGN

Prodotti unici nel loro genere, studiati per massimizzare il comfort di utilizzo e con un inconfondibile tocco Made in Italy. Convinta del potere della creatività, del design e delle nuove tecnologie, l'Azienda ha assunto negli anni un taglio innovativo e in continua evoluzione. Questo atteggiamento l'ha portata a interpretare e anticipare le esigenze presenti e future del mercato, proponendo prodotti all'avanguardia per design e tecnologia. Studiati per massimizzare il comfort di utilizzo e caratterizzati da uno stile unico sono progettati da nomi noti del design.

One-of-a-kind products, designed to maximize the comfort in use with an unmistakable hint of Made in Italy. The Company, firmly confident of the power of creativity, design, and new technologies, has developed over the years innovative and ever-changing traits. This approach has led it to interpret and anticipate the current and future market needs, by proposing state-of-the-art products in terms of design and technology. Designed to maximize the comfort in use and characterised by a unique style, all the items are designed by well-known designers.





#COOL COLORS

FIMA Carlo Frattini amplia i propri orizzonti espressivi con una rinnovata gamma di finiture.

#CROMO Tradizionale finitura a specchio realizzata attraverso uno speciale procedimento galvanico a cromo trivalente, che oltre ad essere totalmente sicuro per la salute e per l'ambiente, conferisce ai prodotti elevate capacità di resistenza e una lucentezza ineguagliabile. **#NICKEL SPAZZOLATO** Finitura dal carattere più contemporaneo, evoca le sensazioni dell'acciaio spazzolato. Realizzato tramite un procedimento di spazzolatura di uno strato di nickel, il prodotto viene reintrodotta all'interno dell'impianto galvanico per stabilizzare la finitura.

#CROMO NERO Raffinata e seducente questa finitura è particolarmente indicata per ambienti bagno dallo stile ricercato. E' realizzata tramite l'immersione del prodotto in una speciale vasca di cromo nero in cui le molecole di ferro donano un'elevata resistenza all'abrasione.

#CROMO NERO SPAZZOLATO Materico e accattivante evoca atmosfere industriali e senza tempo. E' realizzato tramite un procedimento di spazzolatura manuale del prodotto che precede la fase di cromatura all'interno di una vasca di cromo nero.

#ORO Lucente e inconfondibile, è realizzato tramite un rivestimento di oro 24k, ottenuto tramite processo galvanico che dona a ogni prodotto preziose tonalità e riflessi che non passano inosservati.

#ORO SPAZZOLATO Realizzato attraverso la spazzolatura manuale di uno strato di oro a 24k, dona un carattere moderno e spiccatamente scandinavo in grado di rinnovare le linee di ogni prodotto.

#BRONZO Adatta ai bagni più classici ed eleganti, è realizzata tramite un procedimento galvanico di bronzatura e viene sottoposta successivamente a una lavorazione di spazzolatura. Il prodotto è poi protetto da una speciale finitura lucida che dona luminosità e ne preserva dall'ossidazione e dalle alterazioni nel tempo.

#RAME ANTICO Il calore e le tonalità del rame, depositato galvanicamente sul prodotto, rievocano la tradizione mentre la spazzolatura manuale conferisce ad ogni singolo prodotto ombre e striature uniche e irripetibili.

#BIANCO OPACO Distintiva e moderna questa finitura opaca è ottenuta tramite verniciatura polimerica e successiva stabilizzazione in speciali forni per garantirne la più alta resistenza all'abrasione e un colore inalterabile nel tempo.

#NERO OPACO Carismatica e di tendenza, la speciale finitura nero opaco realizzata tramite verniciatura polimerica, dona un effetto materico e setoso a ogni prodotto rendendo ogni linea intrigante e dal grande appeal.

FIMA Carlo Frattini expands its expressive developments with a renewed range of finishes.

#CHROME Traditional mirrored finish, it is made by FIMA Carlo Frattini through a special galvanic process of trivalent chrome, that is not only totally safe for health and environment, but also grants high resistance qualities and a brightness without comparison.

#BRUSHED NICKEL More modern finish, it evokes brushed steel effects. Made by a brushing process of a nickel layer, the product is reintroduced into the galvanic system, in order to fix the finish and guarantee the product over time.

#BLACK CHROME Elegant and fascinating, this finish is produced by immersing the product in a special black chrome tank. The presence of iron molecules gives the product a high resistance to abrasion and makes it suitable for the fanciest bathrooms.

#BRUSHED BLACK CHROME Materic and seductive, it recalls timeless industrial atmospheres. It is made through a manual brushing procedure of the product, that precedes the chrome plating inside a black chrome tank.

#GOLD Shiny and unique, it is made of a 24k gold covering and created through a galvanic process that gives unique shades and reflections to every product.

#BRUSHED GOLD Made through a manual brushing of a 24k gold layer, it gives to each product a modern and distinctly Scandinavian style, able to renew the lines of every product.

#BRONZE Suitable for the most classical and elegant bathrooms, it is made through a galvanic bronzing process, then subjected to brushing procedure. The product is then protected by a special glossy finish, that gives brightness to the product and preserves it from oxidation and alterations over time.

#OLD COPPER The warmth and the shades of copper, deposited on the product by the galvanic process, recall the tradition, while the manual brushing creates unique shades and stripes for each product.

#WHITE MATT Elegant and modern, this matt finish is made by a polymeric painting and a following fixation in special furnaces, in order to guarantee the highest resistance to abrasion and a fixed colour over time.

#BLACK MATT Charming and trendy, the special black matt finish is made through polymeric painting too, offering a materic and silky effect to each product, making every line appealing and seductive.













L'innata eleganza formale, l'inedita modalità fruitiva, la modularità compositiva e la garanzia di un risparmio idrico: questi gli atout di SO, un prodotto che supera i limiti del classico miscelatore, in quanto studiato per assecondare una modalità di uso che permette di scegliere in modo più efficace la quantità e la temperatura desiderata di acqua.

Il segno distintivo di tutta la serie è il comando, un cilindro a cui è stata asportata una porzione mediante una sezione con un piano parallelo alla generatrice, che presenta la parte finale leggermente bombata. Un'altra peculiarità è la possibilità di giocare con abbinamenti cromatici e materici, contribuendo a definire un mood dell'ambiente bagno che rispecchi maggiormente la personalità di chi lo abita.

The formal elegance, the innovative functionality, the modularity and the water saving feature are SO peculiarities, a product that overcomes the limits of a traditional mixer. Water quantity and water temperature can be easily set to use the tap in a more comfortable and efficient way.

The distinctive mark of the whole collection is the shape of the flow rate handle, a cylinder, cut in its section and slightly rounded. Another important feature is given by the wide choice among chromatic and materials combinations, allowing full personalization and the creation of special moods and styles in the bathroom.

SO



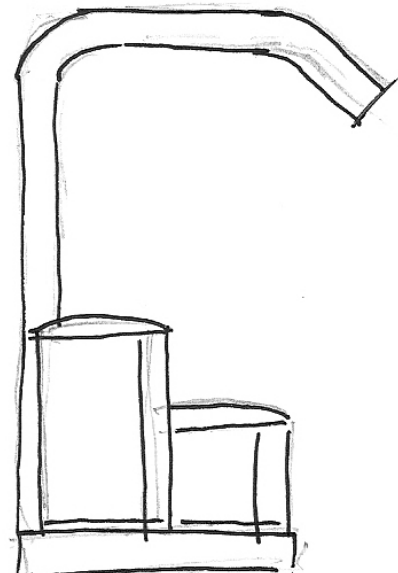
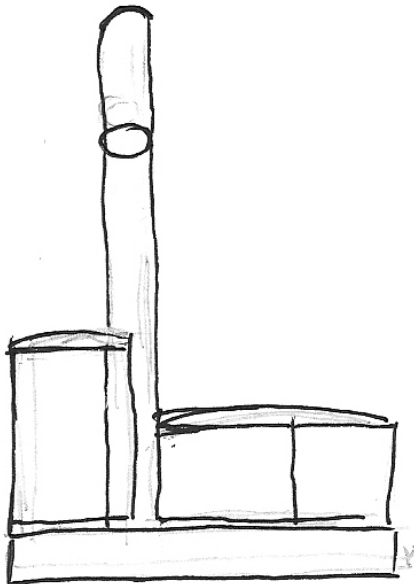
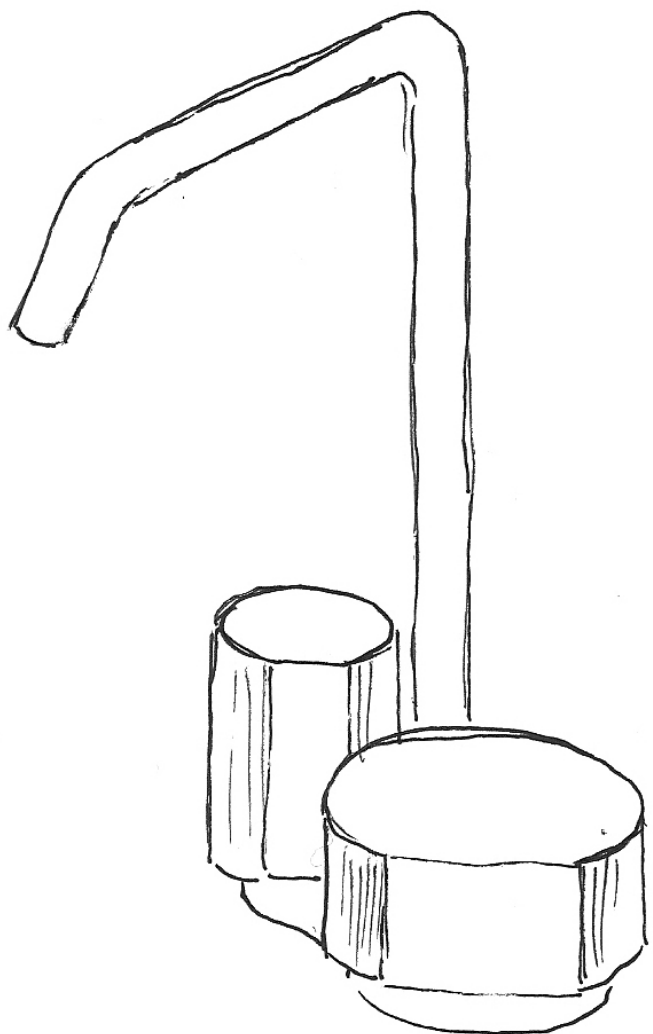



#BLACKSMOKE





**F3171A**

Lavabo monoforo due comandi
con canna Ø 10mm
Double control wash basin mixer
with Ø 10mm spout

**F3171B**

Lavabo monoforo due comandi
con canna Ø 18mm
Double control wash basin mixer
with Ø 18mm spout

**F3171X5**

Miscelatore lavabo a parete
bocca 151 mm
Wall mounted basin mixer
spout 151 mm

**F3191/5**

Lavabo a parete 3 fori
bocca 156 mm
Wall mounted 3-hole basin mixer
spout 156 mm

**F3191A**

Lavabo 3 fori con
canna girevole - h.215mm
3-hole basin tap with
swivel spout - height 215mm

**F3191B**

Lavabo 3 fori con
canna girevole - h.219mm
3-hole basin tap with
swivel spout - height 219mm

**F3191C**

Lavabo 3 fori con
canna girevole - h.310mm
3-hole basin tap with
swivel spout - height 310mm

**F3191D**

Lavabo 3 fori con
canna girevole - h.320mm
3-hole basin tap with
swivel spout - height 320mm

**F3181**

Miscelatore lavabo
Wash basin mixer

**F3172**

Miscelatore bidet
Bidet mixer

**F3189X2**

Miscelatore incasso doccia
con deviatore 2 uscite
Concealed shower mixer
with 2 outlet diverter

**F31899X6**

Miscelatore incasso doccia
con deviatore 2/3 uscite
Concealed shower mixer
with 2/3 outlet diverter

UN SISTEMA UNICO DI PERSONALIZZAZIONE
A UNIQUE CUSTOMIZATION

24 | 25

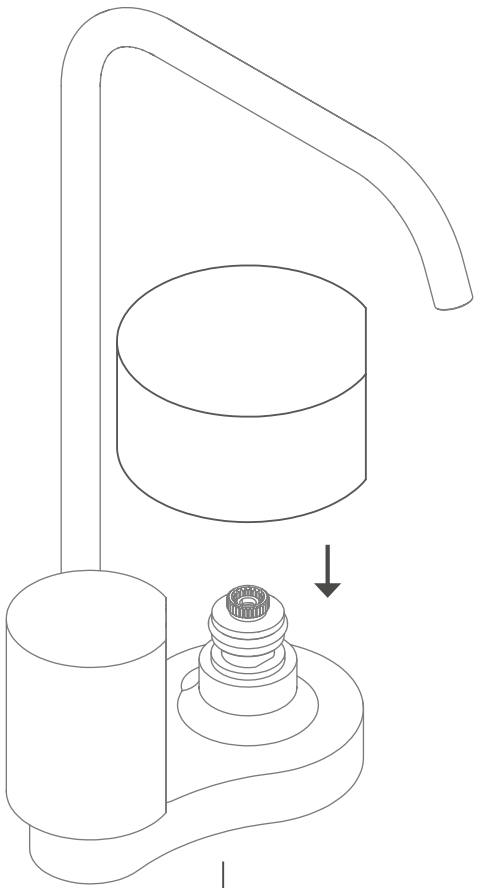

S1+S2
HANDLES

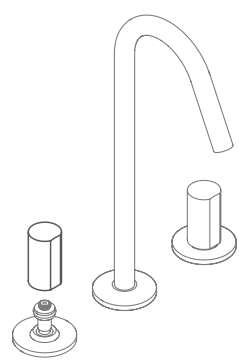

S4
2 HANDLES

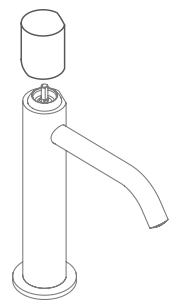

S3
HANDLE

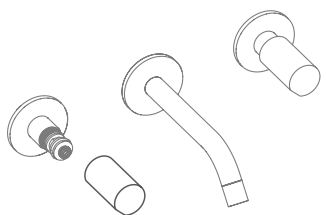

S4
2 HANDLES

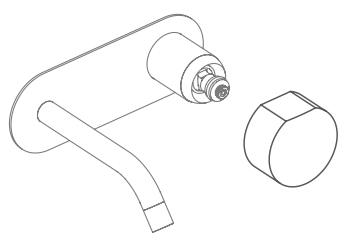

S2
HANDLE

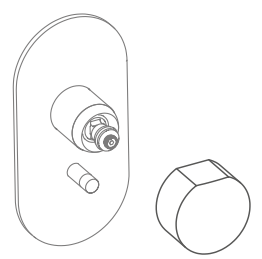

S2
HANDLE

SO

SO

11 FINITURE 11 FINISHES

6 GALVANICHE 6 GALVANIC



CR
Cromo
Chrome



SN
Nickel Spazzolato
Brushed Nickel



CN
Cromo Nero
Black Chrome



CS
Cromo Nero Spazzolato
Brushed Black Chrome



OR
Oro
Gold



OS
Oro Spazzolato
Brushed Gold

2 COLORI 2 COLORS



BS
Bianco Opaco
White Matt



NS
Nero Opaco
Black Matt

3 MATERICHE 3 MATERIALS



CE
Cemento Grigio
Grey Concrete



LC
Legno Chiaro
Light Wood



LS
Legno Scuro
Dark Wood

COME FUNZIONA
HOW IT WORKS

SO, nasce da uno studio attento delle esigenze progettuali odierne e dalla volontà di fornire non solo ai progettisti, ma anche agli utenti finali, infinite possibilità di personalizzazione. La scelta parte dalla selezione della tipologia di miscelatore per lavabo più adatto ai propri bisogni funzionali e di stile: lavabo miscelatore monoforo, lavabo tre fori da appoggio, lavabo tre fori a parete, lavabo miscelatore a parete e l'innovativo e unico lavabo monoforo a doppio comando che permette all'utilizzatore di mantenere preimpostata la temperatura dell'acqua per agire unicamente sulla manopola che ne regola l'erogazione. E' possibile inoltre scegliere non solo la finitura del corpo tra le molteplici varianti galvaniche ma anche la tipologia di bocca di erogazione tra le varie disponibili per ogni modello, conferendo al prodotto un look unico e personalizzato. Definita la forma e la finitura del corpo è infine data la possibilità di selezionare la finitura delle maniglie che, grazie all'esclusivo innesto a pressione, possono essere facilmente installate e sostituite dall'utente finale, permettendo di giocare con abbinamenti cromatici e materici tra il corpo del miscelatore e le maniglie.

Le 11 finiture in cui si declinano le maniglie di So possono essere infatti scelte singolarmente per un effetto total look o combinate tra di loro per dar vita a uno stile unico. Il risultato è un rubinetto dalla grande forza espressiva, capace grazie anche alle nuove finiture materiche di stimolare il tatto e la vista, che contribuisce a definire un mood dell'ambiente bagno in linea con la personalità di chi lo abita.

SO was created to meet the current designing needs and to offer unlimited customization possibilities, not only to designers but also to final customers.

The customer first chooses the type of wash basin mixer more suited to their functional and aesthetical needs: single hole wash basin mixer, three-hole basin one, wall mounted three-hole basin and built-in basin mixer and also the unique and innovative single hole mixer with double control. The water temperature could be pre-set with one handle, so that the customer just have to open and close the water flow with the other one.

Moreover, it is even possible to choose not only the tap body finishing but also the spout type – for a unique and personalized item. Then, the last choice is the handle finishing. The end customer can easily install and replace each handle thanks to the special pressure mechanism, enjoying chromatic and material combinations between the tap and the handles.

In fact, the 11 finishes of SO handles can be individually chosen or combined for a unique style. Even thanks to the material finishings (wood and concrete effect), the tap gets a strong personality that stimulates touch and sight, allowing a full personalization and the creation of special moods and styles in the bathroom.

TEXTURE COLLECTION

MENEGHELLO PAOLELLI ASSOCIATI











Minimalismo e décor per TEXTURE COLLECTION, il nuovo sistema completo di rubinetteria per l'ambiente bagno. Una proposta ideale per il settore contract che nasce dall'interpretazione del design come mezzo principe per manifestare stili e caratteri diversi e adattarsi al meglio ad ogni input progettuale. Questo concept trova massima espressione nelle inedite manopole intercambiabili, veri stilemi della serie, con le quali è possibile ricreare look diversi, sempre ricercati e dal gusto contemporaneo, per bagni di grande carattere, capaci di rinnovarsi proprio come un cambio d'abito. Più in particolare, la versione lavabo è caratterizzata da un sistema a tre fori composto da due manopole a base cilindrica, che uniscono tratti lineari a forme più fluide, ed una canna dai profili stondati in perfetta continuità stilistica con la morbidezza di tutta la linea.

Minimalism and décor for TEXTURE COLLECTION, the new complete system of fittings for the bathroom. An ideal proposal for the contract sector that arises from the interpretation of design as a means of expression of different natures and styles to best suit every design input. This concept is most effectively expressed through the interchangeable handles, real stylistic elements of Texture, with which you can create different looks, always sophisticated and contemporary in taste for special bathrooms that renew themselves just like a change of clothes. More particularly, the version of wash basin is characterized by a system with three holes composed of two knobs with cylindrical base, which combine the linear stretches to more fluid forms, and a rounded profiles spout in perfect stylistic continuity with the softness of the whole line.

TEXTURE COLLECTION



#COOLGREY



ctrl + z





TEXTURE COLLECTION



F5611
Lavabo 3 fori con canna girevole
3-hole basin tap with swivel spout



F5601
Lavabo 3 fori
3-hole basin tap



F5601/5
Lavabo a parete 3 fori
bocca 150 mm
Wall mounted 3-hole basin mixer
spout 150 mm



F5621
Monoforo lavabo
Wash basin mixer



F5602
Monoforo bidet
Bidet mixer



F5614
Gruppo bordo vasca
Deck mounted bath mixer



F5604
Gruppo vasca esterno
con set doccia
Exposed bath tap
with shower set



F5605
Gruppo doccia esterno
con set doccia
Exposed shower tap
with shower set



F5609X2
Miscelatore incasso doccia
con deviatore 2 uscite
Concealed shower mixer
with 2 outlet diverter



F5609X6
Miscelatore incasso doccia
con deviatore 2/3 uscite
Concealed shower mixer
with 2/3 outlet diverter

COVER/MATERIALI COVER/MATERIALS



Cromo
Chrome



Cromo Nero
Black Chrome



Cromo Nero Spazzolato
Brushed Black Chrome



Nickel spazzolato
Brushed Nickel



Oro
Gold



Oro Spazzolato
Brushed Gold

MANOPOLA/FINITURE HANDLE/FINISHES



CR
Cromo
Chrome

SN
Nickel Spazzolato
Brushed Nickel

CN
Cromo Nero
Black Chrome

CS
Cromo Nero Spazzolato
Brushed Black Chrome

OR
Oro
Gold

MANOPOLA/TEXTURE HANDLE/TEXTURE

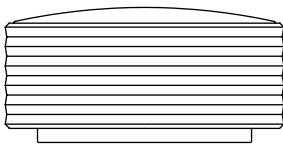

H
Horizontal Texture

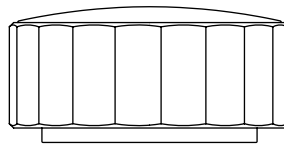

V
Vertical Texture

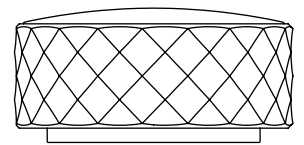

X
Cross Texture

TEXTURE COLLECTION

COME FUNZIONA HOW IT WORKS



Bianco opaco
White Matt



Nero Opaco
Black Matt



Marmo Bianco Carrara
White Carrara Marble



Marmo Nero Portoro
Black Portoro Marble



OS
Oro Spazzolato
Brushed Gold

BS
Bianco opaco
White Matt

NS
Nero Opaco
Black Matt

Texture Collection è un sistema semplice composto da due parti, manopola e cover, facilmente assemblabili tra loro, in grado di dare vita a un prodotto flessibile capace di incontrare i gusti di ognuno e seguire mode e tendenze sempre attuali. Attraverso le numerose combinazioni disponibili si potrà, infatti, ottenere sempre un prodotto finale che soddisfi le proprie esigenze e che sia facilmente personalizzabile.

Cuore del progetto è la ricchezza delle finiture delle manopole, disponibili in tre varianti con segni distinti che ritraggono altrettante texture superficiali tridimensionali: (V) Vertical, contraddistinto dal rigore geometrico di un poligono a 19 facce, (H) Horizontal, che propone un effetto a righe orizzontali tridimensionali dal mood hi-tech, (X) Cross il cui naming svela un'elegante superficie sfaccettata, ispirata alla preziosa pietra diamante, per ambienti sofisticati.

La massima personalizzazione è assicurata dalla possibilità di poter scegliere tra 10 diversi top: cromo, nickel spazzolato, cromo nero, cromo nero spazzolato, oro, oro spazzolato, bianco, nero, marmo bianco di carrara e marmo nero portoro, per originali combinazioni che raccontano di un nuovo senso estetico e creativo custom made.

Texture Collection is a simple system composed of two parts: handle and cover that can be easily put together to create a flexible product to suit all tastes while following trends and styles. With the numerous combinations available you can always come up with the final product you want. The heart of the project is the richness of the knobs finishings, available in three variants with distinct signs depicting tridimensional surface textures: (V) Vertical, characterized by geometric rigor of a polygon with 19 faces, (H) Horizontal, offering a tridimensional effect with horizontal stripes of hi-tech mood, (X) Cross whose naming reveals an elegant faceted surface, inspired by the precious stone diamond, for sophisticated environments. A further personalization is ensured by the possibility to choose from 10 different handle tops: chrome, brushed nickel, black chrome, brushed black chrome, gold, brushed gold, white, black, white Carrara marble and black Portoro marble, for original combinations of a new aesthetic sense and a creative custom made product.

COVER



MANOPOLA
HANDLE

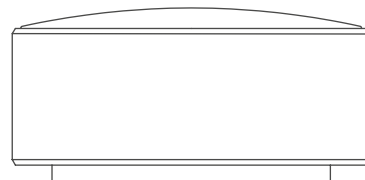

ECLIPSE

GIUSEPPE BAVUSO











Rigorose forme scultoree, ma al contempo sinuose e seducenti, rendono la collezione ECLIPSE un "oggetto" d'autore dal grande appeal visivo, dove la morbida armonia dei dettagli si sposa con la geometria minimale d'insieme. Il risultato più evidente è un volume equilibrato e invitante. Cuore del progetto - nonché elemento caratterizzante e innovativo - è la leva che alloggia armoniosamente nel corpo del miscelatore, diventando un unico volume e ricomponendo alla perfezione il disegno dell'ovale, leggibile dall'alto.

Thanks to its clear-cut, sculpted, but also flexuous and alluring lines, the ECLIPSE collection is a highly appealing design "object", in which skilfully harmonised details go hand in hand with a generally minimalist geometry, the final result being a well-balanced, captivating volume.

The very heart of this project and its most innovative and distinguishing element is the lever elegantly moulded in the tap body to create one single volume and result in a flawless oval shape, visible from above.

ECLIPSE



#CANDYPINK





ECLIPSE



F3911
Miscelatore lavabo alto
Sleeve basin mixer



F3901
Miscelatore lavabo
Wash basin mixer



F3902
Miscelatore bidet
Bidet mixer



F3900X5
Miscelatore lavabo a parete
bocca 177 mm
Wall mounted basin mixer
spout 177 mm

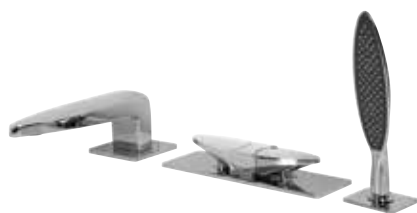

F3914
Miscelatore bordo vasca
Deck mounted bath mixer



F3919X1
Miscelatore incasso doccia
Concealed shower mixer



F3919X2
Miscelatore incasso doccia
con deviatore 2 uscite
Concealed shower mixer
with 2 outlet diverter



F3908X3
Gruppo incasso doccia
con soffione a parete
Built-in shower tap with
wall mounted showerhead



F3929X2
Doppio miscelatore incasso
Double built-in mixer



F3929X3
Doppio miscelatore incasso
con deviatore
Double built-in mixer with diverter

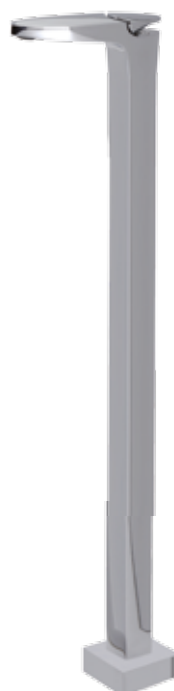

F3921
Miscelatore lavabo a pavimento
Floor mounted basin mixer

NOMOS GO

CASTIGLIA ASSOCIATI











Stilisticamente, la collezione NOMOS GO propone forme incisive, quasi scultoree, dove i componenti strutturali come il corpo, la leva e la manopola si integrano e si fondono perfettamente uno nell'altro. Il risultato è un'estrema armonia a livello estetico.

Altra peculiarità di NOMOS GO è il rompigetto con riduttore di portata che contribuisce al risparmio energetico.

The NOMOS GO collection offers, with its style, cutting even sculptural shapes, where structural components as the body, the lever and the handle are perfectly integrated and merged one into the others. The result is an extreme aesthetic harmony. One more feature of NOMOS GO is the integrated water saving aerator that contributes to save energy.

NOMOSGO



#SANDSTONE







F4161/H
Miscelatore lavabo alto
Sleeve basin mixer



F4161L
Miscelatore lavabo
Wash basin mixer



F4161
Miscelatore lavabo
Wash basin mixer



F4162
Miscelatore bidet
Bidet mixer



F4201X5
Miscelatore lavabo a parete
bocca 153 mm
Wall mounted basin mixer
spout 153 mm



F4164
Miscelatore vasca esterno
con set doccia
Exposed bath mixer
with shower set



F4165
Miscelatore doccia esterno
con set doccia
Exposed shower mixer
with shower set



F4191
Miscelatore lavabo monoforo
con bocca a soffitto
Single-hole basin mixer with
ceiling mounted spout



F4174
Miscelatore bordo vasca
Deck mounted bath mixer



F4169X2
Miscelatore incasso doccia
con deviatore 2 uscite
Concealed shower mixer
with 2 outlet diverter



F4169X6
Miscelatore incasso doccia
con deviatore 2/3 uscite
Concealed shower mixer
with 2/3 outlet diverter

FLUID

MENEGHELLO PAOLELLI ASSOCIATI











Gli elementi emergono in maniera plastica dalla propria base. Canna e mixer cilindrici si elevano dalla base verso l'alto, con un'operazione di morphing. La forma fluida permette di alloggiare la cartuccia sopra il livello del piano e di allineare così la canna del rubinetto al foro del lavabo. Cromo, Bianco opaco, Nero opaco... FLUID è in sintonia con più finiture perché il progetto dei volumi e la loro disposizione valorizzano riflessi e superfici.

The various elements elegantly arise from their own base. The cylindrical spout and mixer rise up from the base thanks to a morphing process. Their flexuous shape allows to insert the cartridge above the main surface, thus aligning the tap spout with the mounting hole on the wash-basin.

Chrome, White Matt, Black Matt... FLUID is equally perfect with different finishes because its carefully designed elements and their harmonious arrangement further enhance the beauty of surfaces and reflections.

FLUID



#MUSTARD







F3851
Miscelatore lavabo
Wash basin mixer



F3852
Miscelatore bidet
Bidet mixer



F3861
Miscelatore lavabo a parete
bocca 160 mm
Wall mounted basin mixer
spout 160 mm



F3861L
Miscelatore lavabo a parete
bocca 200 mm
Wall mounted basin mixer
spout 200 mm



F3854
Miscelatore vasca esterno
con set doccia
Exposed bath mixer
with shower set



F3855
Miscelatore doccia esterno
con set doccia
Exposed shower mixer
with shower set



F3859X1
Miscelatore incasso doccia
Concealed shower mixer



F3859X2
Miscelatore incasso doccia
con deviatore 2 uscite
Concealed shower mixer
with 2 outlet diverter



F3859X6
Miscelatore incasso doccia
con deviatore 2/3 uscite
Concealed shower mixer
with 2/3 outlet diverter

DESOTO

HANS THYGE RAUNKJÆR











Dal perfetto connubio tra tecnologia e scenografia si genera una cascata d'acqua armoniosa. DE SOTO rompe la definizione di semplice erogatore, affermandosi come un vero oggetto di arredo, originale ed esclusivo. Qui è il dettaglio a fare la differenza.

La creatività si libera nella stanza da bagno e l'originale ed estroso carattere di DE SOTO si racconta nei suoi cinque colorati accessori, che completano il design del miscelatore. Questa linea è così rappresentata dalla sua multifunzionalità e impreziosita da tutti gli elementi che la compongono: l'energia delle linee e della forma, il vigore del getto a cascata, i riflessi delle cromature, l'armonia dei colori.

The perfect combination of technology and beauty generates an harmonious waterfall.

DE SOTO breaks the idea of simple mixer and set itself as a true decor object, original and exclusive. Creativity is set free in your bathroom and DE SOTO's original and ingenious character is reflected by its colorful accessories, that compose its design. This collection is represented by its functionality and adorned by all its elements: dynamic lines and shapes, an harmonious cascade, chrome reflections and a color harmony.

DESOTO



#LIGHTWOOD







F3661
Miscelatore lavabo alto
Sleeve basin mixer



F3651
Miscelatore lavabo
Wash basin mixer



F3652
Miscelatore bidet
Bidet mixer



F3681
Miscelatore lavabo a parete
bocca 137 mm
Wall mounted basin mixer
spout 137 mm



F3654
Miscelatore vasca esterno
con set doccia
Exposed bath mixer
with shower set



F3655
Miscelatore doccia esterno
con set doccia
Exposed shower mixer
with shower set



F3659X1
Miscelatore incasso doccia
Concealed shower mixer



F3659X2
Miscelatore incasso doccia
con deviatore 2 uscite
Concealed shower mixer
with 2 outlet diverter



F3659X6
Miscelatore incasso doccia
con deviatore 2/3 uscite
Concealed shower mixer
with 2/3 outlet diverter



F3654/4
Miscelatore vasca a pavimento
Floor mounted bath mixer

NEXT

CASTIGLIA ASSOCIATI











NEXT nasce dalla ricerca di inedite soluzioni formali basate sul rigore e la semplicità. Peculiarità della collezione è la sezione fortemente caratterizzata generata da un ovale tagliato che mette in evidenza la faccia piatta frontale e si conclude con la manopola. Cuore del progetto, la manopola proposta in due versioni: la prima, inedita nella forma, corta a "pomo" per un'immagine dal carattere forte e accattivante; la seconda a leva più semplice, ma formalmente integrata nel disegno del miscelatore per un'assoluta eleganza formale.

Innovative stylish solutions based on strictness and simplicity. NEXT main feature is the shape of its profile, created by cutting an oval in order to highlight the frontal face and the harmonious lever. The core of the project is the lever, available in two versions: the first one, unique in its shape, is short and flat with a strong and charming aspect, the second one is a lever, more simple but designed in harmony with the lines of the body for an absolute formal elegance.

NEXT



#SAGEGREEN







F3941/HN

Miscelatore lavabo alto
Sleeve basin mixer

F3941LN

Miscelatore lavabo
Wash basin mixer

F3941N

Miscelatore lavabo
Wash basin mixer



F3931/HN

Miscelatore lavabo alto
Sleeve basin mixer

F3931LN

Miscelatore lavabo
Wash basin mixer

F3931N

Miscelatore lavabo
Wash basin mixer



F3942N

Miscelatore bidet leva lunga
Bidet mixer

F3932N

Miscelatore bidet leva corta
Bidet mixer



F3961X5

Miscelatore lavabo a parete
bocca 139 mm
Wall mounted basin mixer
spout 139 mm



F3951X5

Miscelatore lavabo a parete
bocca 139 mm
Wall mounted basin mixer
spout 139 mm



F3944

Miscelatore bordo vasca
Deck mounted bath mixer



F3934

Miscelatore vasca esterno
con set doccia
Exposed bath mixer
with shower set



F3949X1 - F3939X1

Miscelatore incasso doccia
Concealed shower mixer



F3949X2 - F3939X2

Miscelatore incasso doccia
con deviatore 2 uscite
Concealed shower mixer
with 2 outlet diverter



F3949X6 - F3939X6

Miscelatore incasso doccia
con deviatore 2/3 uscite
Concealed shower mixer
with 2/3 outlet diverter



F3934/4

Miscelatore vasca
a pavimento
Floor mounted
bath mixer

ZETA

MENEGHELLO PAOLELLI ASSOCIATI











Una proposta classica e al contempo moderna: questa è ZETA, la collezione caratterizzata da uno stile senza tempo, perfetta per ogni ambiente bagno. Tratti razionali si sposano con tratti morbidi: le superfici esterne perfettamente rettangolari sono unite nella parte inferiore da una superficie che piano piano si ammorbidisce, creando un feeling inedito, originale e innovativo. ZETA si contraddistingue per la grande leggerezza formale grazie alle cartucce molto piccole che assicurano la massima resa estetica senza compromettere comfort e funzionalità.

A formal but at the same time modern proposal: this is ZETA, the collection featured by a long lasting style perfect in every bathroom. Tough lines merge with smooth shapes: the perfectly rectangular surfaces join the body with soft lines creating a unique, original and innovative feeling. ZETA is marked by the great lightness thanks to the small cartridges that ensure a unique beauty without compromising comfort and functionality.

ZETA



#AQUAMARINE







F3961/HN
Miscelatore lavabo alto
Sleeve basin mixer



F3961LN
Miscelatore lavabo
Wash basin mixer



F3961N
Miscelatore lavabo
Wash basin mixer



F3962N
Miscelatore bidet
Bidet mixer



F3971X5
Miscelatore lavabo a parete
bocca 144 mm
Wall mounted basin mixer
spout 144 mm



F3971VX5
Miscelatore lavabo a parete
bocca 144 mm
Wall mounted basin mixer
spout 144 mm



F3964
Miscelatore vasca esterno
con set doccia
Exposed bath mixer
with shower set



F3974
Miscelatore bordo vasca
Deck mounted bath mixer



F3969X2
Miscelatore incasso doccia
con deviatore 2 uscite
Concealed shower mixer
with 2 outlet diverter



F3969X6
Miscelatore incasso doccia
con deviatore 2/3 uscite
Concealed shower mixer
with 2/3 outlet diverter

QUAD

MENEGHELLO PAOLELLI ASSOCIATI











Forme leggere ed eleganti sono le vere protagoniste della collezione QUAD, in cui il carattere sofisticato del cerchio sposa l'incisività del quadrato. La collezione dallo stile contemporaneo e dal carattere incisivo incarna la sfida di trovare il giusto equilibrio tra fluidità, eleganza e solidità; tra semplicità d'utilizzo e innovazione ingegneristica.

Light and elegant shapes are the focus of QUAD collection where round lines are perfectly combined together with square ones. Its contemporary style and sharp traits represent the right balance among fluidity, elegance and solidity as well as between user friendliness and innovation.

QUAD



#TURQUOISE



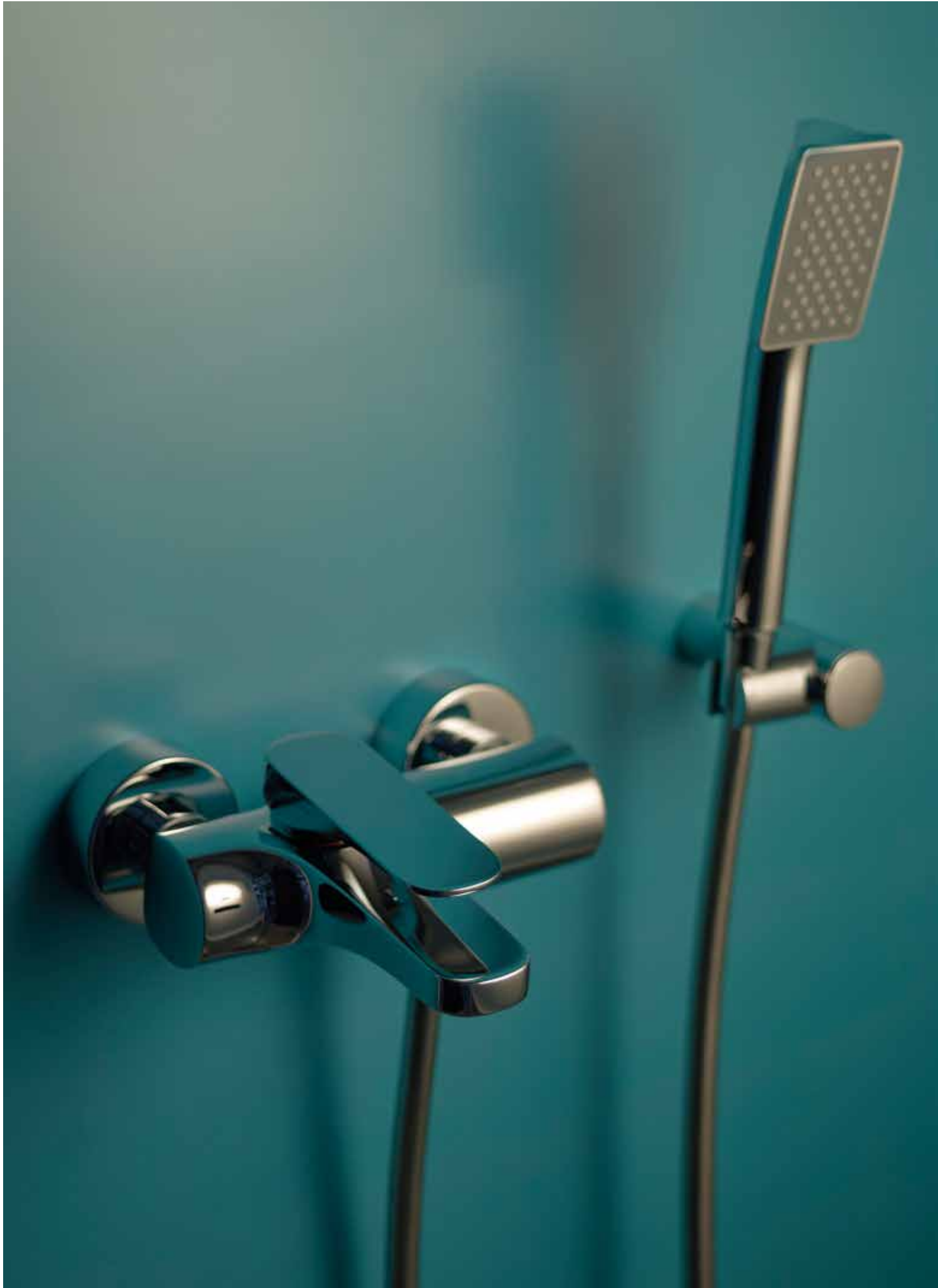



F3731
Miscelatore lavabo alto
Sleeve basin mixer



F3721L
Miscelatore lavabo
Wash basin mixer



F3721
Miscelatore lavabo
Wash basin mixer



F3722
Miscelatore bidet
Bidet mixer



F3741X5
Miscelatore lavabo a parete
bocca 148 mm
Wall mounted basin mixer
spout 148 mm



F3741LVX5
Miscelatore lavabo a parete
bocca 198 mm
Wall mounted basin mixer
spout 198 mm



F3734
Miscelatore bordo vasca
Deck mounted bath mixer



F3735
Miscelatore doccia esterno
con set doccia
Exposed shower mixer
with shower set



F3723/1
Miscelatore incasso doccia
Concealed shower mixer



F3729X2
Miscelatore incasso doccia
con deviatore 2 uscite
Concealed shower mixer
with 2 outlet diverter



F3724/4
Miscelatore vasca a pavimento
Floor mounted bath mixer

SPILOTECH

CENTRO RICERCA FIMA











La purezza e l'essenzialità delle linee sono esaltate e impreziosite da una rinnovata gamma di finiture e da raffinate texture, tre segni materici distinti che riproducono altrettante superfici tridimensionali con un gioco di rimandi dalla basetta alla leva, integrata armoniosamente nel corpo del miscelatore.

Texture (X) Cross il cui naming svela un'elegante e lussuosa superficie finemente sfaccettata, ispirata al prezioso diamante intagliato, ideale per ambienti sofisticati; (V) Vertical, contraddistinta dal rigore geometrico di un poligono a 19 facce; (G) Godronata, che propone un effetto micro-diamantato dal mood fortemente industriale.

SPILLO TECH è testimone di un modo diverso di progettare la semplicità, con una spiccata attenzione al dettaglio che trasforma un miscelatore dal design senza tempo in uno di tendenza.

The minimal shapes become iconic thanks to three different precious decorative elements that create an innovative visual language in the bathroom and reflect the identity and the style of the people who live it.

The elegant and simple shapes are enhanced and enriched by a wide range of finishes and by stylish textures. Three different material signs that reproduce three-dimensional surfaces with a suggestive connection between base and handle, harmoniously integrated in the mixer. They are: (X) Cross, whose naming reveals an elegant and luxurious faceted surface, inspired by the precious stone diamond, excellent for sophisticated environments; (V) Vertical, characterized by the geometric rigor of a 19 faces polygon; (G) Knurled, a micro-diamond effect with a strongly industrial mood.

SPILLO TECH is the result of a different way to design simplicity. The care for details transforms a timeless mixer into a trendy one.

SPILLOTECH



SPILLOTECH



F3031/HXSX
Miscelatore lavabo alto
Sleeve basin mixer



F3031LXSX
Miscelatore lavabo
Wash basin mixer



F3031XSX
Miscelatore lavabo
Wash basin mixer



F3032XSX
Miscelatore bidet
Bidet mixer



F3041X
Miscelatore lavabo
con canna girevole
Wash basin mixer
with swivel spout



F3051X5X
Miscelatore lavabo a parete
bocca 151 mm
Wall mounted basin mixer
spout 151 mm



F3051X9X
Miscelatore lavabo a parete
bocca 150 mm a 90°
Wall mounted basin mixer
spout 90° - 150 mm



F3051LX9X
Miscelatore lavabo a parete
bocca 200 mm a 90°
Wall mounted basin mixer
spout 90° - 200 mm



F3034X
Miscelatore vasca esterno
con set doccia
Exposed bath mixer
with shower set



F3035X
Miscelatore doccia esterno
con set doccia
Exposed shower mixer
with shower set



F3039X1X
Miscelatore incasso doccia
Concealed shower mixer



F3039X2X
Miscelatore incasso doccia
con deviatore 2 uscite
Concealed shower mixer
with 2 outlet diverter

SPILOUP

CENTRO RICERCA FIMA











SPILLO UP si caratterizza per i suoi profili sottili e una forma slanciata e minimalista che conferisce alla serie un carattere incisivo. La collezione presenta un profilo dal design assolutamente lineare che sembra plasmare lo scorrere continuo dell'acqua e che migliora la prestazione dei miscelatori in termini di erogazione.

SPILLO UP is featured by thin outlines and a slim shape that gives the collection a biting aspect for a never-ending iconic product. The collection shows linear shapes, following the continuous flow of water and improving the performance of products in distributing water.

SPILLOUP

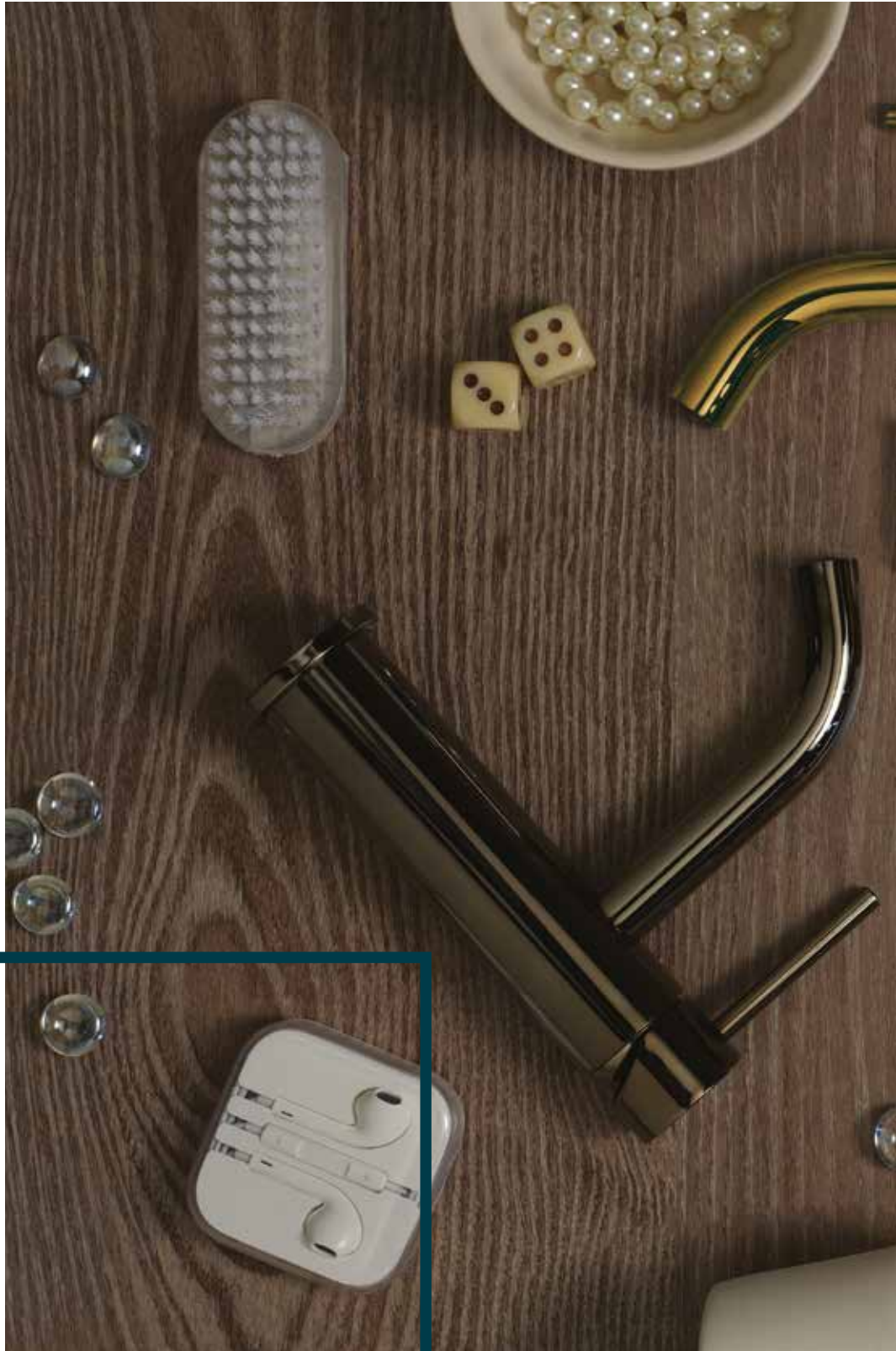

#SHEERBLUE





SPILLOUP



F3031/HXS
Miscelatore lavabo alto
Sleeve basin mixer

F3031LXS
Miscelatore lavabo
Wash basin mixer

F3031XS
Miscelatore lavabo
Wash basin mixer



F3031/H
Miscelatore lavabo alto
Sleeve basin mixer

F3031L
Miscelatore lavabo
Wash basin mixer

F3031
Miscelatore lavabo
Wash basin mixer



F3032XS
Miscelatore bidet
Bidet mixer

F3032
Miscelatore bidet
Bidet mixer



F3041
Miscelatore lavabo
con canna girevole
Wash basin mixer
with swivel spout



F3051X5
Miscelatore lavabo a parete
bocca 151 mm
Wall mounted basin mixer
spout 151 mm

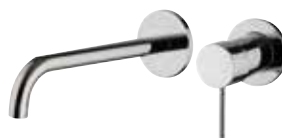

F3051LX9
Miscelatore lavabo a parete
bocca 200 mm a 90°
Wall mounted basin mixer
spout 90° - 200 mm



F3034
Miscelatore vasca esterno
con set doccia
Exposed bath mixer
with shower set



F3044
Miscelatore bordo vasca
Deck mounted bath mixer



F3033/1
Miscelatore incasso doccia
Concealed shower mixer



F3039X2
Miscelatore incasso doccia
con deviatore 2 uscite
Concealed shower mixer
with 2 outlet diverter



F3034/6
Miscelatore vasca
a pavimento
Floor mounted bath mixer







SPILLO STEEL



F3071/HINOX
Miscelatore lavabo alto
Sleeve basin mixer



F3071LINOX
Miscelatore lavabo
Wash basin mixer



F3071INOX
Miscelatore lavabo
Wash basin mixer



F3072INOX
Miscelatore bidet
Bidet mixer



F3081X5INOX
Miscelatore lavabo a parete
bocca 151 mm
Wall mounted basin mixer
spout 151 mm



F3081X8INOX
Miscelatore lavabo a parete
bocca 156 mm
Wall mounted basin mixer
spout 156 mm



F3081LX9INOX
Miscelatore lavabo a parete
bocca 202 mm
Wall mounted basin mixer
spout 202 mm



F3074INOX
Miscelatore bordo vasca
Deck mounted bath mixer



F3073INOX
Miscelatore incasso doccia
Concealed shower mixer



F3079X2INOX
Miscelatore incasso doccia
con deviatore 2 uscite
Concealed shower mixer
with 2 outlet diverter



F3079X6INOX
Miscelatore incasso doccia
con deviatore 2/3 uscite
Concealed shower mixer
with 2/3 outlet diverter











MAST si distingue per la pulizia delle linee: tratti sottili e slanciati caratterizzano la bocca e il corpo del miscelatore, la basetta è integrata e il profilo della leva è essenziale e minimale. Forme geometricamente perfette per un design efficiente e funzionale che dialogano con ogni ambiente bagno portando armonia delle proporzioni.

MAST stands out for the cleanliness of its design: thin and slim lines distinguish the spout and the body of the mixer, the base is integrated and the outline of the lever is more essential and minimal. Perfect geometric shapes for a functional and rational design that adapt to any bathroom furniture creating a sense of harmonious proportions.

MAST

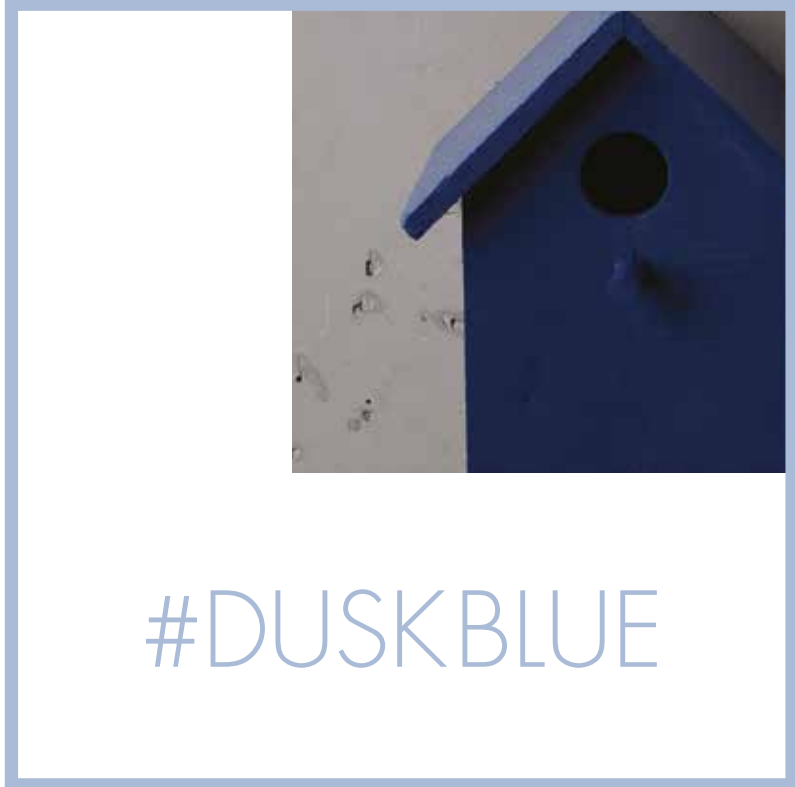

#DUSKBLUE





Rotoxi

MÆLKESÆBE
MILK SOAP
uden parabener
without parabens





F3131/H
Miscelatore lavabo alto
Sleeve basin mixer



F3131L
Miscelatore lavabo
Wash basin mixer



F3131
Miscelatore lavabo
Wash basin mixer



F3132
Miscelatore bidet
Bidet mixer



F3151
Miscelatore lavabo
con canna girevole
Wash basin mixer
with swivel spout



F3151F
Miscelatore lavabo
con canna fusa girevole
Wash basin mixer
with casted swivel spout



F3141X5
Miscelatore lavabo a parete
bocca 149 mm
Wall mounted basin mixer
spout 149 mm



F3141X8
Miscelatore lavabo a parete
bocca 154 mm
Wall mounted basin mixer
spout 154 mm



F3144
Miscelatore bordo vasca
Deck mounted bath mixer



F3134
Miscelatore vasca esterno
con set doccia
Exposed bath mixer
with shower set



F3139X2
Miscelatore incasso doccia
con deviatore 2 uscite
Concealed shower mixer
with 2 outlet diverter



F3139X6
Miscelatore incasso doccia
con deviatore 2/3 uscite
Concealed shower mixer
with 2/3 outlet diverter

MAXIMA

CENTRO RICERCA FIMA











Geometrie perfette e pulite contraddistinguono MAXIMA, la serie dalle forme cilindriche che abbinata alle manopole "a croce" creano un gioco armonioso e dinamico, rendendola ideale per ambienti minimal in cui si respira un'atmosfera moderna. Uno stile essenziale che esprime il giusto equilibrio tra fluidità ed eleganza.

Sharp and perfect lines characterise MAXIMA, the series with cylindrical shapes combined with "cross" handles that create a sense of harmony and dynamism as well – ideal for minimal but modern spaces. Its essential flair expresses the right balance between fluidity and elegance.

MAXIMA



#LILAC







F5311W
Monoforo lavabo
Wash basin mixer



F5301W
Lavabo 3 fori
3-hole basin mixer



F5312W
Monoforo bidet
Bidet mixer



F5302W
Bidet 3 fori
3-hole bidet mixer



F5321/5
Lavabo a parete 3 fori
bocca 150 mm
Wall mounted 3-hole
basin mixer - spout 150 mm



F5304
Gruppo vasca esterno
con set doccia
Exposed bath mixer
with shower set



F5305
Gruppo doccia esterno
con set doccia
Exposed shower mixer
with shower set



F5314
Gruppo bordo vasca
Deck mounted bath mixer



F5309X2
Miscelatore incasso doccia
con deviatore 2 uscite
Concealed shower mixer
with 2 outlet diverter



F5309X6
Miscelatore incasso doccia
con deviatore 2/3 uscite
Concealed shower mixer
with 2/3 outlet diverter



F5305/2
Miscelatore doccia con colonna
Shower column











Un design accattivante e moderno, dove le linee fluide e morbide del corpo sono in contrasto con i profili "affilati" della bocca, per una combinazione geometrica di forte seduzione e dall'appeal contemporaneo. Il corpo del miscelatore della serie SPOT, che si distingue per le sue linee morbide ma decise, è caratterizzato da una base larga che si rastrema leggermente verso l'alto per alleggerirne il design, come la larghezza della bocca e della leva che si stringono verso l'aeratore.

An attractive modern design, where the fluid and soft lines of the body of the mixer are in contrast with the "sharp" profiles of the spout, for a geometric combination of strong seduction and contemporary appeal. The body of the mixer, which is distinguished by its soft line, is characterized by a wide base which narrows slightly upwards and the width of the spout and lever which also narrows to the aerator. Single hole wash basin mixer leans forward at an angle of the spout in order to properly steer the water flow.

SPOT



#PRIMROSE







F3001/H
Miscelatore lavabo alto
Wash basin mixer



F3001L
Miscelatore lavabo
Wash basin mixer



F3001
Miscelatore lavabo
Wash basin mixer



F3002
Miscelatore bidet
Bidet mixer



F3011
Miscelatore lavabo
con canna girevole
Wash basin mixer
with swivel spout



F3011F
Miscelatore lavabo
con canna fusa girevole
Wash basin mixer
with casted swivel spout



F3021X5
Miscelatore lavabo a parete
bocca 154 mm
Wall mounted basin mixer
spout 154 mm



F3005
Miscelatore doccia esterno
con set doccia
Exposed shower mixer
with shower set



F3014
Miscelatore bordo vasca
Deck mounted bath mixer



F3003/1
Miscelatore incasso doccia
Concealed shower mixer



F3009X2
Miscelatore incasso doccia
con deviatore 2 uscite
Concealed shower mixer
with 2 outlet diverter



F3009X6
Miscelatore incasso doccia
con deviatore 2/3 uscite
Concealed shower mixer
with 2/3 outlet diverter

SERIE4

CENTRO RICERCA FIMA











Design democratico e massima funzionalità: queste le caratteristiche distintive della linea SERIE 4. Rassicurante nelle forme familiari, si caratterizza per i volumi morbidi. Attraverso i profili curvilinei, la base cilindrica si unisce, infatti, alla bocca di erogazione e alla leva di comando assicurando ergonomia e massime prestazioni. Progettata per una facile installazione la linea, ampia e articolata, grazie alla sua essenzialità formale, si armonizza con eleganza in ambienti bagno dalla personalità e dagli stili diversi.

Democratic design and utmost functionality: these are the features that distinguish SERIE 4. Comforting with its familiar shapes, is characterized by its soft volumes. Through curvilinear outlines, the cylindrical base is connected with the spout and with the lever for a perfect ergonomics and best performance.

Designed for a simple installation, the wide collection matches perfectly in every bathroom with essential shapes and elegance.

SERIE 4



#CHERRYRED

I'm an
y bitsy
eenie
eenie
book

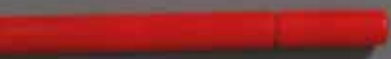



SERIE 4



F3761/H
Miscelatore lavabo alto
Wash basin mixer



F3761L
Miscelatore lavabo
Wash basin mixer



F3761
Miscelatore lavabo
Wash basin mixer



F3762
Miscelatore bidet
Bidet mixer



F3781W
Miscelatore lavabo
con canna girevole
Wash basin mixer
with swivel spout



F3781FN
Miscelatore lavabo
con canna fusa girevole
Wash basin mixer
with casted swivel spout



F3760LX5
Miscelatore lavabo a parete
bocca 203 mm
Wall mounted basin mixer
spout 203 mm



F3764
Miscelatore vasca esterno
con set doccia
Exposed bath mixer
with shower set



F3765
Miscelatore doccia esterno
con set doccia
Exposed shower mixer
with shower set



F3769X1
Miscelatore incasso doccia
Concealed shower mixer



F3769X6
Miscelatore incasso doccia
con deviatore 2/3 uscite
Concealed shower mixer
with 2/3 outlet diverter

FIMABOXES

CENTRO RICERCA FIMA



fima
made in Italy

fima
made in Italy

fima
made in Italy

fima
made in Italy

HOT

COLD

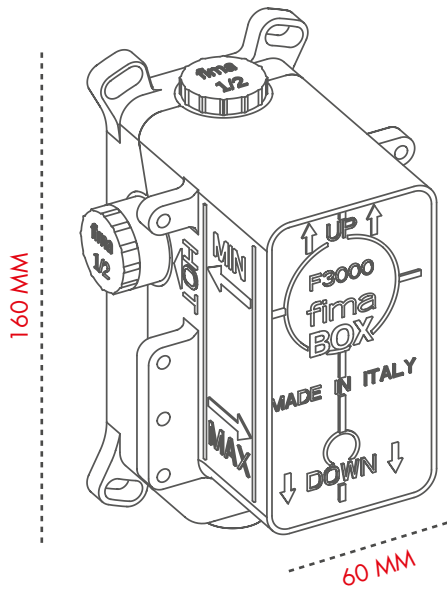

MECCANICO
MECHANICAL



TERMOSTATICO
THERMOSTATIC

COMPATIBILE CON PARTI ESTERNE SIA MECCANICHE CHE TERMOSTATICHE
COMPATIBLE TO EITHER EXTERNAL MECHANICAL OR THERMOSTATIC SHOWER MIXERS



1.2 USCITE
OUTLETS



UNIVERSALE PER TUTTE LE SERIE
UNIVERSAL FOR ALL COLLECTIONS



FACILE DA INSTALLARE
EASY INSTALLATION



CLASSE "A" PER RUMOROSITÀ
CLASS "A" FOR NOISE
UNI EN ISO 3822. < di 20dB max flow



NON TRASMETTE VIBRAZIONI
DOES NOT TRANSMIT VIBRATIONS



IMPERMEABILE
WATERPROOF



DEVIATORE PUSH & PULL
PUSH & PULL DIVERTER



OTTONE DZR
DZR BRASS

PROFONDITÀ INCASSO
LESS PROTRUSIVE INSTALLATION

60MM

TOLLERANZA DI INSTALLAZIONE
INSTALLATION DEPTH TOLERANCE

30MM

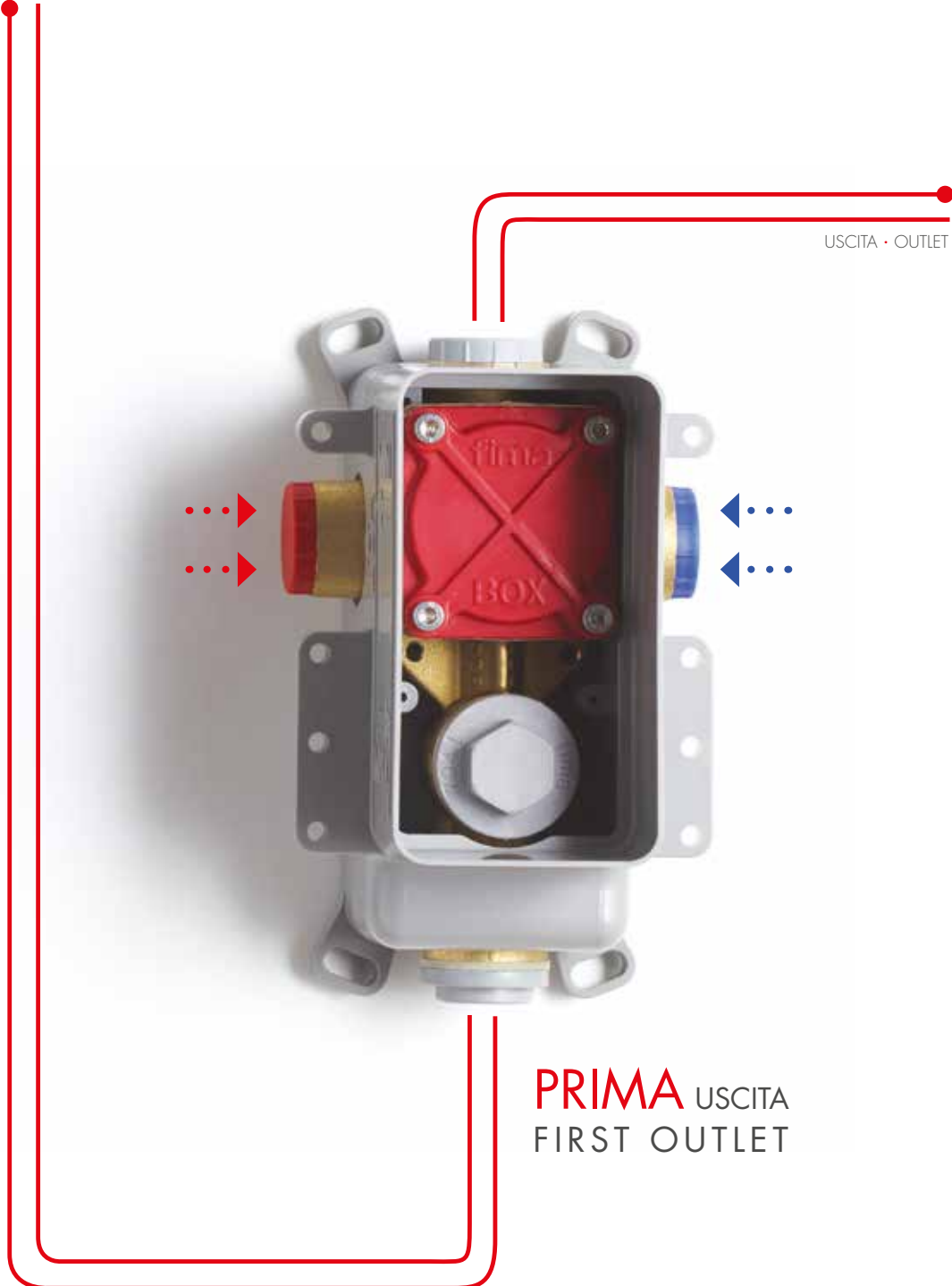

USCITA · OUTLET

PRIMA USCITA
FIRST OUTLET

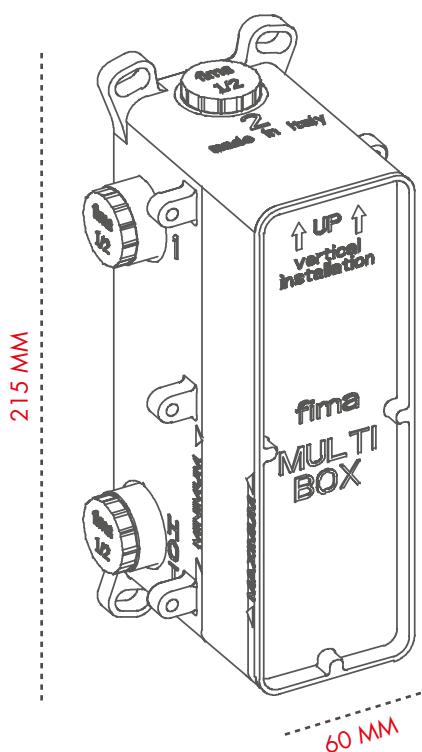

MECCANICO
MECHANICAL



TERMOSTATICO
THERMOSTATIC

COMPATIBILE CON PARTI ESTERNE SIA MECCANICHE CHE TERMOSTATICHE
COMPATIBLE TO EITHER EXTERNAL MECHANICAL OR THERMOSTATIC SHOWER MIXERS



2-3 USCITE
OUTLETS



UNIVERSALE PER TUTTE LE SERIE
UNIVERSAL FOR ALL COLLECTIONS



FACILE DA INSTALLARE
EASY INSTALLATION



NON TRASMETTE VIBRAZIONI
DOES NOT TRANSMIT VIBRATIONS



IMPERMEABILE
WATERPROOF



OTTONE DZR
DZR BRASS

PROFONDITÀ INCASSO
LESS PROTRUSIVE INSTALLATION

60MM

TOLLERANZA DI INSTALLAZIONE
INSTALLATION DEPTH TOLERANCE

30MM

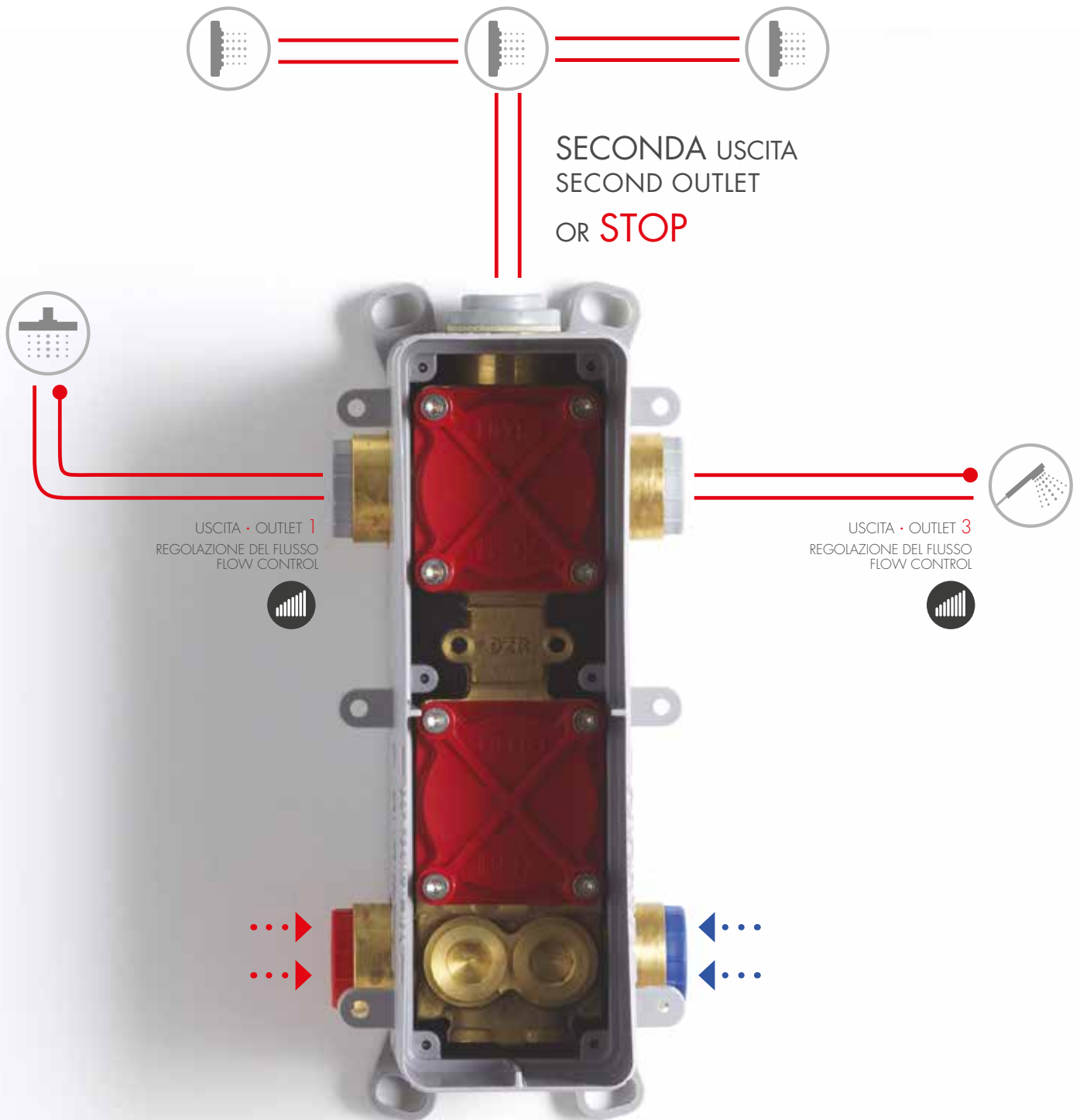

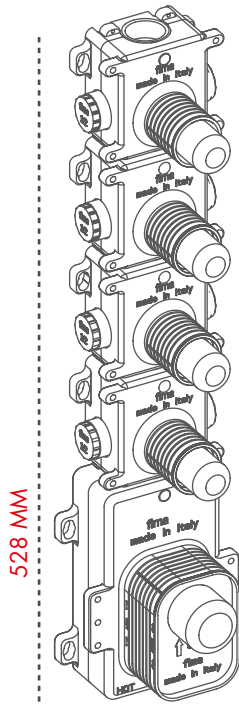

F2464

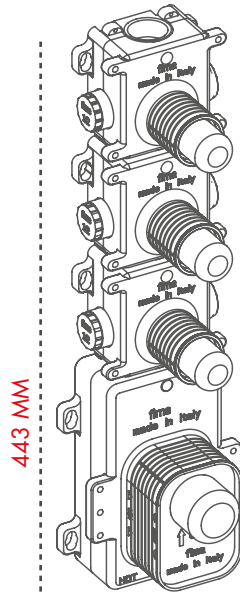

F2463

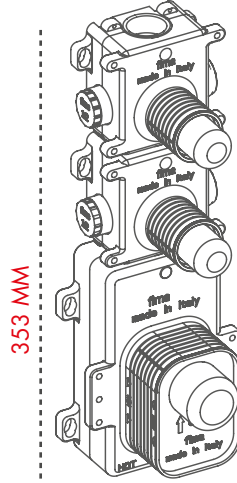

F2462

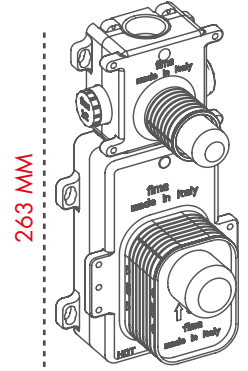

F2461



4 USCITE
OUTLETS

3 USCITE
OUTLETS

2 USCITE
OUTLETS

1 USCITA
OUTLET



UNIVERSALE PER TUTTE LE SERIE
UNIVERSAL FOR ALL COLLECTIONS



FACILE DA INSTALLARE
EASY INSTALLATION



NON TRASMETTE VIBRAZIONI
DOES NOT TRANSMIT VIBRATIONS



IMPERMEABILE
WATERPROOF



OTTONE DZR
DZR BRASS



INSTALLAZIONE ORIZZONTALE O VERTICALE
HORIZONTAL OR VERTICAL INSTALLATION



TUTTE LE USCITE CONTEMPORANEAMENTE
ALL OUTLETS SIMULTANEOUSLY



TERMOSTATICO
THERMOSTATIC



FINO A 50L.MIN.
UP TO 50L.MIN.

PROFONDITÀ INCASSO
LESS PROTRUSIVE INSTALLATION

60MM

TOLLERANZA DI INSTALLAZIONE
INSTALLATION DEPTH TOLERANCE

30MM



USCITA · OUTLET

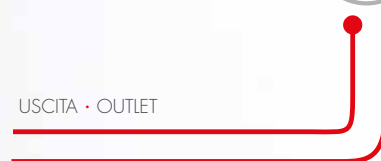

USCITA · OUTLET



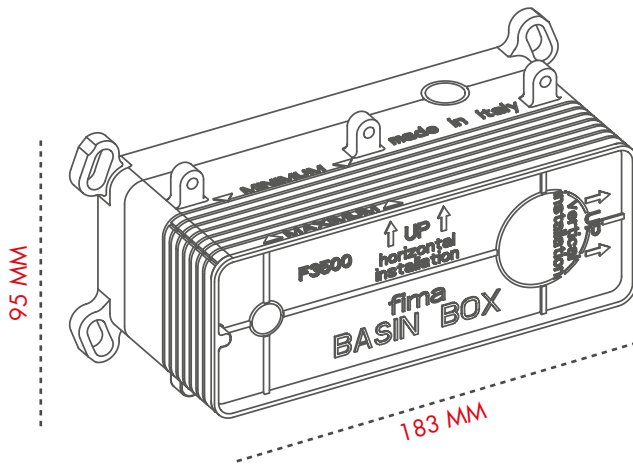

MECCANICO
MECHANICAL



1 USCITA
OUTLET



UNIVERSALE PER TUTTE LE SERIE
UNIVERSAL FOR ALL COLLECTIONS



FACILE DA INSTALLARE
EASY INSTALLATION



NON TRASMETTE VIBRAZIONI
DOES NOT TRANSMIT VIBRATIONS



IMPERMEABILE
WATERPROOF



INSTALLAZIONE ORIZZONTALE O VERTICALE
HORIZONTAL OR VERTICAL INSTALLATION



OTTONE DZR
DZR BRASS

PROFONDITÀ INCASSO
LESS PROTRUSIVE INSTALLATION

50MM

TOLLERANZA DI INSTALLAZIONE
INSTALLATION DEPTH TOLERANCE

30MM

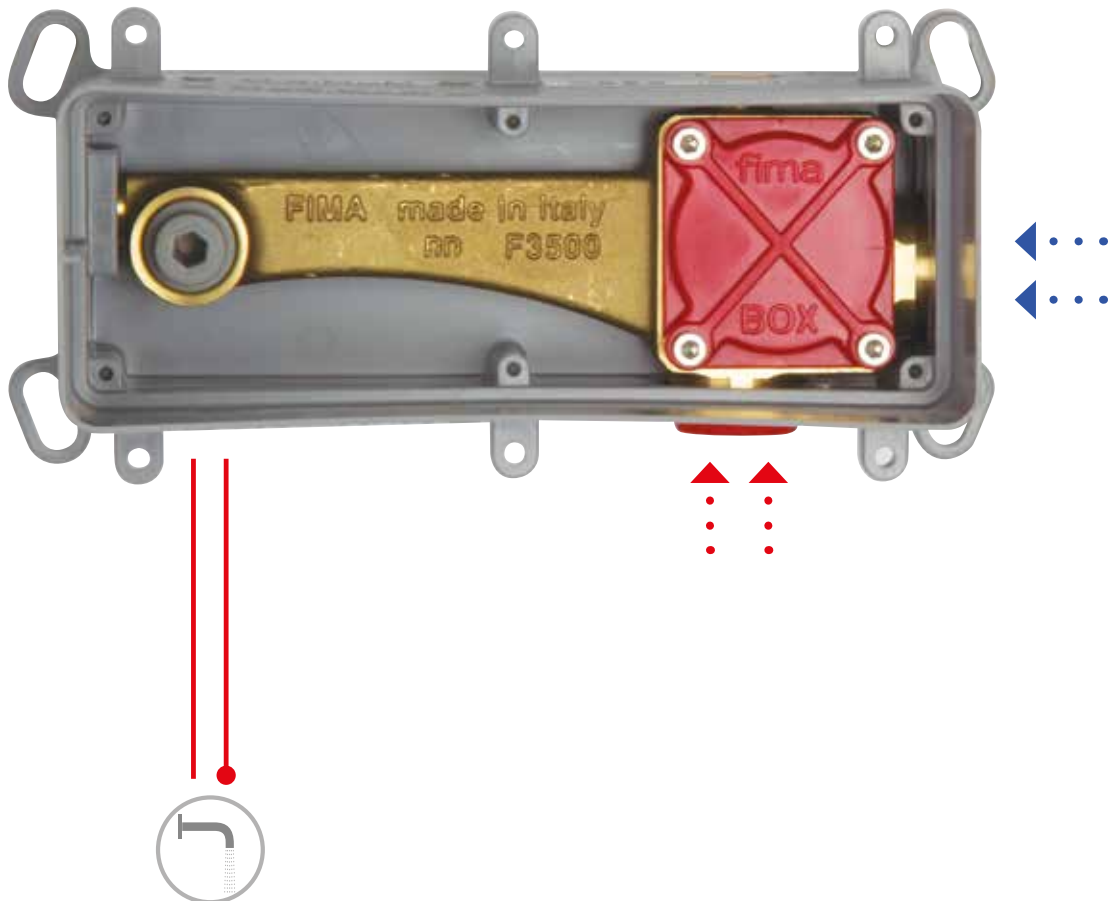

fimatwinbox

for ECLIPSE

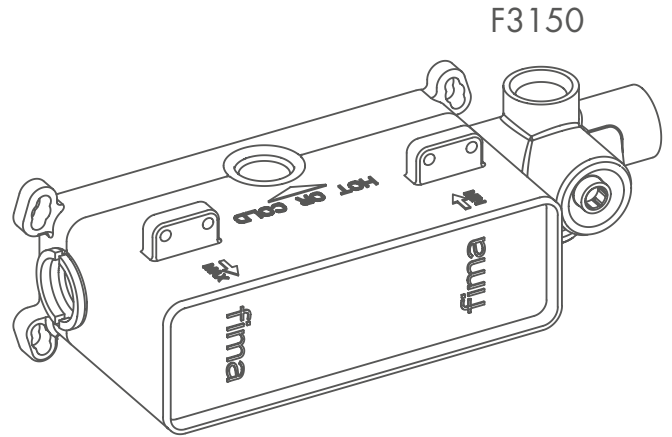
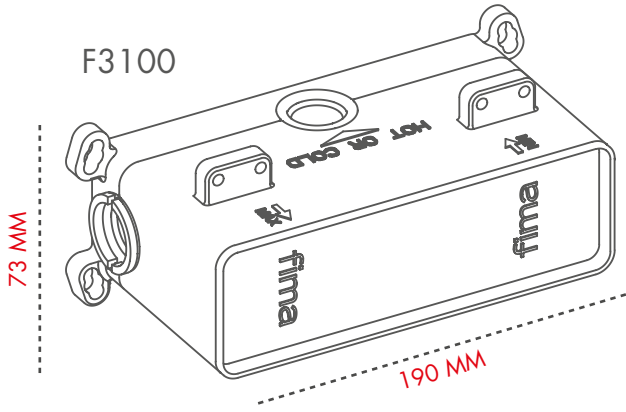

2.3 USCITE
OUTLETS



FACILE DA INSTALLARE
EASY INSTALLATION



NON TRASMETTE VIBRAZIONI
DOES NOT TRANSMIT VIBRATIONS



IMPERMEABILE
WATERPROOF



OTTONE DZR
DZR BRASS



GESTIONE INDIPENDENTE DELLA TEMPERATURA
INDIPENDENT CONTROL OF TEMPERATURE



TUTTE LE USCITE CONTEMPORANEAMENTE
ALL OUTLETS SIMULTANEOUSLY



MECCANICO
MECHANICAL

PROFONDITÀ INCASSO
LESS PROTRUSIVE INSTALLATION

72MM

TOLLERANZA DI INSTALLAZIONE
INSTALLATION DEPTH TOLERANCE

30MM

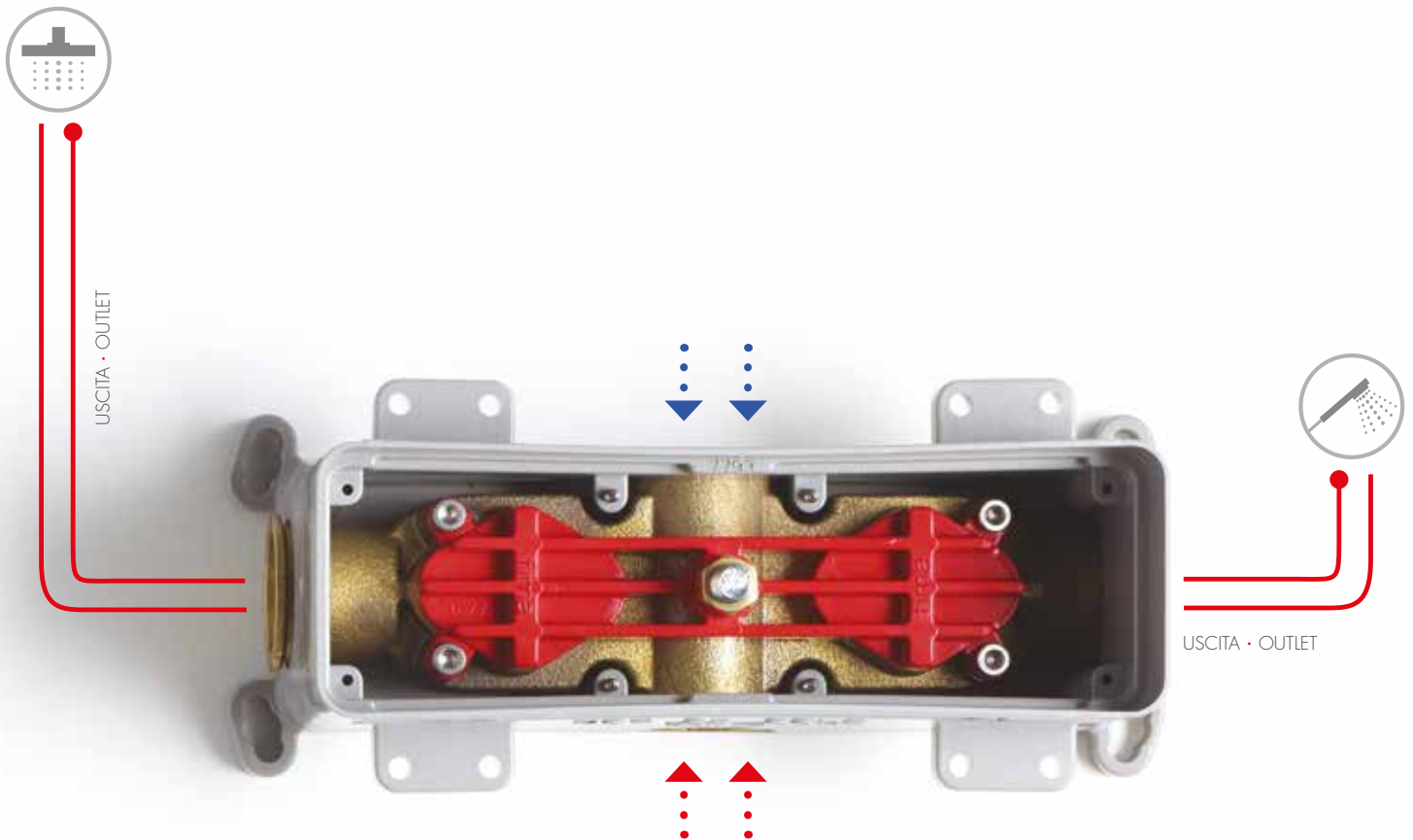

DOPPIO MISCELATORE CON GESTIONE
INDIPENDENTE DI FLUSSO E PORTATA
DOUBLE MIXER WITH INDEPENDENT CONTROL OF FLOW AND TEMPERATURE

follow me



fimacf.com

graphic project
FIMA CARLO FRATTINI
photo
WALTER ZERLA

fima | CARLO FRATTINI®
F U T U R O C R I A T I V O

tutti i diritti riservati / All rights reserved
printed in Italy 05-2018



Fima Carlo Frattini S.p.A.
28010 - Briga Novarese (NO)
Via Borgomanero, 105
tel. +39 0322 9549 (r.a.)
fax. +39 0322 956149
e-mail: info@fimacl.com
www.fimacl.com

fima | **CARLO FRATTINI**[®]
r u b i n e t t e r i e



MAST







F3134CR



Mast si distingue per la pulizia delle linee: tratti sottili e slanciati caratterizzano la bocca e il corpo del miscelatore, la basetta è integrata e il profilo della leva è essenziale e minimale.

Forme geometricamente perfette per un design efficiente e funzionale che dialogano con ogni ambiente bagno portando armonia delle proporzioni.

Mast stands out for the cleaning of its design: thin and slim lines distinguish the spout and the body of the mixer, the base is integrated and the outline of the lever is more essential and minimal. Perfect geometric lines in a functional and rational design adapted to every bathroom thanks to the harmonious proportions.

MAST



NOTA/NOTE
per soffione, doccia e
flessibile consultare il
listino prezzi in vigore
please see the existing
price list for showerhead,
handshower and flexible



F3131/H
Miscelatore lavabo alto
Sleeve basin mixer



F3131L
Miscelatore lavabo alto
Sleeve basin mixer



F3131
Miscelatore lavabo
Wash basin mixer



F3132
Miscelatore bidet
Bidet mixer



F3151
Miscelatore lavabo
con canna girevole
Wash basin mixer
with swivel spout



F3151F
Miscelatore lavabo
con canna fusa girevole
Wash basin mixer
with casted swivel spout



F3141X5
Miscelatore lavabo a parete
bocca 149 mm
Wall mounted basin mixer
spout 149 mm



F3141X8
Miscelatore lavabo a parete
bocca 154 mm
Wall mounted basin mixer
spout 154 mm



F3152
Miscelatore bidet
con canna girevole
Bidet mixer with
swivel spout



F3144
Miscelatore bordo vasca
Deck mounted bath mixer



F3134
Miscelatore esterno vasca
con set doccia
Exposed bath mixer
with shower set



F3135
Miscelatore esterno doccia
con set doccia
Exposed shower mixer
with shower set



F3133/1
Miscelatore incasso doccia
Concealed shower mixer



F3139X1
Miscelatore incasso doccia
Concealed shower mixer



F3139X2
Miscelatore incasso doccia
con deviatore 2 uscite
Concealed shower mixer
with 2 outlets diverter



F3139X6
Miscelatore incasso doccia
con deviatore 2/3 uscite
Concealed shower mixer
with 2/3 outlets diverter





MAST



SERIE 22



F3831CR



CARTUCCE

WATER SAVING CARTRIDGE

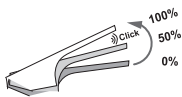

ENERGY SAVING CARTRIDGE

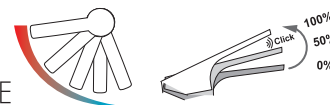

La cartuccia Water Saving ha due caratteristiche speciali che permettono di risparmiare da un lato energia, dall'altro acqua:
 Risparmia acqua grazie all'apertura con doppio scatto: un primo scatto corrisponde al 50% dell'apertura totale della maniglia.
 Risparmia inoltre energia perchè erogando meno acqua si ha un risparmio d'acqua calda.

The Water Saving cartridge has two exclusive features to provide economies of water consumption overall, and of hot water use specifically:
 Save water by opening the handle with a double shot: the first step corresponds to the 50% of the total opening of the handle.
 Save energy because using less water you save hot water.

L'apertura dell'acqua fredda in posizione centrale permette di ridurre il consumo di energia evitando lo spreco di acqua calda. L'acqua miscelata è ottenuta girando la leva verso sinistra.

La cartuccia consente inoltre di risparmiare acqua grazie all'apertura con doppio scatto: un primo scatto corrisponde infatti al 50% dell'apertura totale della maniglia.

The cold water opening in a central position allows to reduce the water consumption by avoiding the waste of hot water.
 The mixed water is obtained by turning the lever to the left.
 The cartridge allows also to save water by opening the handle with a double shot: the first step corresponds in fact to the 50% of the total opening of the handle.

SISTEMA DI MOVIMENTAZIONE A DISCHI CERAMICI PIÙ RESISTENTE NEL TEMPO E PIÙ SENSIBILE ALLA REGOLAZIONE DI PORTATA E TEMPERATURA DELL'ACQUA
 CERAMIC DISK MOVEMENT: DURABLE, MORE RESISTANT IN TIME AND HIGH PRECISION OF FLOW AND TEMPERATURE REGULATION

SISTEMA REGOLATORE DI PORTATA
 FLOW REGULATION SYSTEM

SISTEMA REGOLATORE DI PORTATA
 FLOW REGULATION SYSTEM

LIMITATORE DI TEMPERATURA
 TEMPERATURE LIMITER

LIMITATORE DI TEMPERATURA
 TEMPERATURE LIMITER

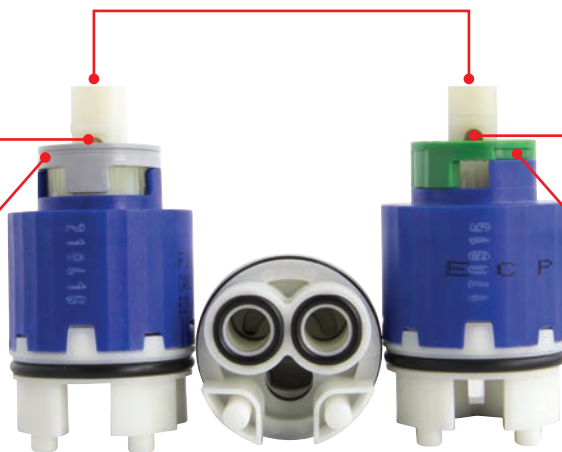

WATER SAVING CARTRIDGE

ENERGY SAVING CARTRIDGE

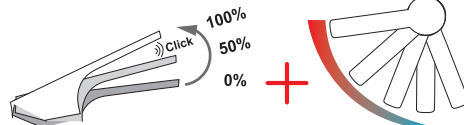

CARTUCCIA E COMPONENTI A CONTATTO CON L'ACQUA
 IN PLASTICA AD USO ALIMENTARE
 FOOD GRADE PLASTIC CARTRIDGE AND COMPONENTS



Per tutti i nostri prodotti utilizziamo ottone a basso contenuto di piombo, in linea con la Direttiva Europea 98/83/CE.
 For all our products we use low lead content brass, in line with the European Directive 98/83/CE.



F3830X5CR

SERIE 22



F3831/H
Miscelatore lavabo alto
Sleeve basin mixer



F3831L
Miscelatore lavabo alto
Sleeve basin mixer



F3831
Miscelatore lavabo
Wash basin mixer



F3832
Miscelatore bidet
Bidet mixer



F3841
Miscelatore lavabo
con canna girevole
Wash basin mixer
with swivel spout



F3842
Miscelatore bidet
con canna girevole
Bidet mixer
with swivel spout



Miscelatore lavabo a parete
Wall mounted basin mixer
F3830X5
bocca 154 mm spout 154 mm
F3830LX5
bocca 204 mm spout 204 mm



F3834/9
Miscelatore vasca monoforo
con deviatore
Bath mixer with diverter



F3834
Miscelatore esterno vasca
con set doccia
Exposed bath mixer
with shower set



F3835
Miscelatore esterno doccia
con set doccia
Exposed shower mixer
with shower set



F3839X6
Miscelatore incasso doccia
con deviatore 2/3 uscite
Concealed shower mixer
with 2/3 outlets diverter



F3165/RP251
Miscelatore doccia esterno
meccanico con colonna accorciabile,
soffione Ø 250 mm e doccetta
Mechanical exposed shower mixer
with column, Ø 250 mm showerhead
and shower set



F3833/1
Miscelatore incasso doccia
Concealed shower mixer



F3839X1
Miscelatore incasso doccia
Concealed shower mixer



F3839X2
Miscelatore incasso doccia
con deviatore 2 uscite
Concealed shower mixer
with 2 outlets diverter



SERIE 22

Fima Carlo Frattini S.p.A.
28010 - Briga Novarese (NO)
Via Borgomanero, 105
tel. +39 0322 9549 (r.a.)
fax. +39 0322 956149
info@fimacl.com
www.fimacl.com

fima | CARLO FRATTINI®
r u b i n e t t e r i e



SO

M A G A Z I N E

L'EVOLUZIONE DEL MISCELATORE DAL TWIST CONTEMPORANEO

THE EVOLUTION OF A MIXER REVISITED
WITH A CONTEMPORARY TWIST





SO

DAVIDE VERCELLI DESIGN

Designer e Ingegnere Davide Vercelli fonda il proprio studio che si occupa di sviluppo di prodotto, di strategie di crescita, di comunicazione e di reti. Design, bellezza, responsabilità e profitto sono le parole chiave che segnano ogni intervento.

Un approccio multidisciplinare e trasversale ha permesso allo studio negli anni di affiancare i clienti come consulente globale.

Vanta numerosi riconoscimenti internazionali: dieci selezioni per l'Adi Design Index, due al Compasso d'Oro, due premi Young & Design, tre Design Plus, un premio all'Ida (International Design Awards) e un Good Design Awards.

Da maggio 2015 è direttore creativo di Fima Carlo Frattini.

Designer and engineer, Davide Vercelli founded his studio and specialized in product design, strategical marketing and communication. Aesthetics, functionality, ethics and production efficiency are the key-words, that mark every project. Thanks to his multidisciplinary and cross-cutting approach, established important collaborations with several companies as global consultant.

He received many international awards: ten mentions for the Adi Design Index, two for Compasso d'Oro, two awards for the Young & Design, three Design Plus, one recognition at Ida (International Design Awards) and one Good Design Awards.

Since 2015 is collaborating with Fima Carlo Frattini as the company artistic director.



AWARDWINNER 2019
DESIGN PLUS



L'INNATA ELEGANZA FORMALE, L'INEDITA MODALITÀ FRUITIVA,
LA MODULARITÀ COMPOSITIVA E LA GARANZIA DI UN RISPARMIO IDRICO:
QUESTI GLI ATOUT DI SO. SEGNO DISTINTIVO DI TUTTA LA SERIE È IL COMANDO,
UN CILINDRO A CUI È STATA ASPORTATA UNA PORZIONE MEDIANTE UNA
SEZIONE CON UN PIANO PARALLELO ALLA GENERATRICE, CHE PRESENTA LA
PARTE FINALE LEGGERMENTE BOMBATA, UNA PARTICOLARITÀ CHE
DIMOSTRA ATTENZIONE ALL'ESTETICA E ALL'ERGONOMIA.

The formal elegance, the innovative functionality, the modularity and the water saving feature are SO peculiarities. The distinctive mark of the whole collection is the shape of the handle, a cylinder, cut in its section and slightly rounded. A detail that proves the keen attention of the company to aesthetics, as well as ergonomics.





COOL COLORS

UNA RINNOVATA ED AMPIA GAMMA DI FINITURE

A RENEWED AND WIDE RANGE OF FINISHES

In grado di conferire un forte impatto decorativo e di esaltare in modo inedito la silhouette di ogni prodotto, tutte le finiture galvaniche sono realizzate grazie all'innovativo impianto automatizzato a basso impatto ambientale, che oltre a testimoniare il costante impegno dell'Azienda verso una produzione eco-sostenibile, è in grado di garantire una qualità unica, impassibile al trascorrere del tempo. #CROMO Tradizionale finitura a specchio realizzata attraverso uno speciale procedimento galvanico a cromo trivalente, che oltre ad essere totalmente sicuro per la salute e per l'ambiente, conferisce ai prodotti elevate capacità di resistenza e una lucentezza ineguagliabile. #NICKEL SPAZZOLATO Finitura dal carattere più contemporaneo, evoca le sensazioni dell'acciaio spazzolato. Realizzato tramite un procedimento di spazzolatura di uno strato di nickel, il prodotto viene reintrodotta all'interno dell'impianto galvanico per stabilizzare la finitura. #CROMO NERO Raffinata e seducente questa finitura è particolarmente indicata per ambienti bagno dallo stile ricercato. E' realizzata tramite l'immersione del prodotto in una speciale vasca di cromo nero in cui le molecole di ferro donano un'elevata resistenza all'abrasione. #CROMO NERO SPAZZOLATO Materico e accattivante evoca atmosfere industriali e senza tempo. E' realizzato tramite un procedimento di spazzolatura manuale del prodotto che precede la fase di cromatura all'interno di una vasca di cromo nero. #ORO Lucente e inconfondibile, è realizzato tramite un rivestimento di oro 24k, ottenuto tramite processo galvanico che dona a ogni prodotto preziose tonalità e riflessi che non passano inosservati. #ORO SPAZZOLATO Realizzato attraverso la spazzolatura manuale di uno strato di oro a 24k, dona un carattere moderno e spiccatamente scandinavo in grado di rinnovare le linee di ogni prodotto. #BRONZO Adatta ai bagni più classici ed eleganti, è realizzata tramite un procedimento galvanico di bronzatura e viene sottoposta successivamente a una lavorazione di spazzolatura. Il prodotto è poi protetto da una speciale finitura lucida che dona luminosità e ne preserva dall'ossidazione e dalle alterazioni nel tempo. #RAME ANTICO Il calore e le tonalità del rame, depositato galvanicamente sul prodotto, rievocano la tradizione mentre la spazzolatura manuale conferisce ad ogni singolo prodotto ombre e striature uniche e irripetibili. #BIANCO OPACO Distintiva e moderna questa finitura opaca è ottenuta tramite verniciatura polimerica e successiva stabilizzazione in speciali forni per garantirne la più alta resistenza all'abrasione e un colore inalterabile nel tempo. #NERO OPACO Carismatica e di tendenza, la speciale finitura nero opaco realizzata tramite verniciatura polimerica, dona un effetto materico e setoso a ogni prodotto rendendo ogni linea intrigante e dal grande appeal.

Able to create unique decorative effects and to exalt every product shape in a new way, all the galvanic finishes are produced thanks to the eco-friendly innovative automated system, which not only shows the company constant care towards eco-production, but is also able to guarantee a unique quality, unchanging over time.

#CHROME Traditional mirrored finish, it is made through a special galvanic process of trivalent chrome, that is not only totally safe for health and environment, but also grants high resistance qualities and a brightness without comparison. #BRUSHED NICKEL More modern finish, it evokes brushed steel effects. Made by a brushing process of a nickel layer, the product is reintroduced into the galvanic system, in order to fix the finish and guarantee the product over time. #BLACK CHROME Elegant and fascinating, this finish is produced by immersing the product in a special black chrome tank. The presence of iron molecules gives to the product a high resistance to abrasion and makes it suitable for the fanciest bathrooms. #BRUSHED BLACK CHROME Materic and seductive, it recalls timeless industrial atmospheres. It is made through a manual brushing procedure of the product, that precedes the chrome plating inside a black chrome tank. #GOLD Shiny and unique, it is made of a 24k gold covering and created through a galvanic process that gives unique shades and reflections to every product. #BRUSHED GOLD Made through a manual brushing of a 24k gold layer, it gives to each product a modern and distinct Scandinavian style, able to renew the lines of every product. #BRONZE Suitable for the most classical and elegant bathrooms, it is made through a galvanic bronzing process, then subjected to brushing procedure. The product is then protected by a special glossy finish, that gives brightness to the product and preserves it from oxidation and alterations over time. #OLD COPPER The warmth and the shades of copper, deposited on the product by the galvanic process, recall the tradition, while the manual brushing creates to each product unique shades and stripes. #WHITE MATT Elegant and modern, this matt finish is made by a polymeric painting and a following fixation in special furnaces, in order to guarantee the highest resistance to abrasion and a fixed colour over time. #BLACK MATT Charming and trendy, the special black matt finish is made through polymeric painting too, offering a materic and silky effect to each product, making every line appealing and seductive.

COME FUNZIONA/HOW IT WORKS

11 FINITURE 11 FINISHES

6 GALVANICHE 6 GALVANIC



CR
Cromo
Chrome



SN
Nickel Spazzolato
Brushed Nickel



CN
Cromo Nero
Black Chrome



CS
Cromo Nero Spazzolato
Brushed Black Chrome



OR
Oro
Gold



OS
Oro Spazzolato
Brushed Gold

2 COLORI 2 COLORS



BS
Bianco Opaco
White Matt



NS
Nero Opaco
Black Matt

3 MATERICHE 3 MATERIALS



CE
Cemento Grigio
Grey Concrete



LC
Legno Chiaro
Light Wood



LS
Legno Scuro
Dark Wood

SO, nasce da uno studio attento delle esigenze progettuali odierne e dalla volontà di fornire non solo ai progettisti, ma anche agli utenti finali, infinite possibilità di personalizzazione. La scelta parte dalla selezione della tipologia di miscelatore per lavabo più adatto ai propri bisogni funzionali e di stile: lavabo miscelatore monoforo, lavabo tre fori da appoggio, lavabo tre fori a parete, lavabo miscelatore a parete e l'innovativo e unico lavabo monoforo a doppio comando che permette all'utilizzatore di mantenere preimpostata la temperatura dell'acqua per agire unicamente sulla manopola che ne regola l'erogazione. E' possibile inoltre scegliere non solo la finitura del corpo tra le molteplici varianti galvaniche ma anche la tipologia di bocca di erogazione tra le varie disponibili per ogni modello, conferendo al prodotto un look unico e personalizzato. Definita la forma e la finitura del corpo è infine data la possibilità di selezionare la finitura delle maniglie che, grazie all'esclusivo innesto a pressione, possono essere facilmente installate e sostituite dall'utente finale, permettendo di giocare con abbinamenti cromatici e materici tra il corpo del miscelatore e le maniglie. Le 11 finiture in cui si declinano le maniglie di SO possono essere infatti scelte singolarmente per un effetto total look o combinate tra di loro per dar vita a uno stile unico. Il risultato è un rubinetto dalla grande forza espressiva, capace grazie anche alle nuove finiture materiche di stimolare il tatto e la vista, che contribuisce a definire un mood dell'ambiente bagno in linea con la personalità di chi lo abita.

SO was created to meet the current designing needs and to offer unlimited customization possibilities, not only to designers but also to final customers. The customer first chooses the type of wash basin mixer more suited to their functional and aesthetical needs: single hole wash basin mixer, three-hole basin one, wall mounted three-hole basin and built-in basin mixer and also the unique and innovative single hole mixer with double control. The water temperature could be pre-set with one handle, so that the customer just have to open and close the water flow with the other one. Moreover, it is even possible to choose not only the tap body finishing but also the spout type – for a unique and personalized item. Then, the last choice is the handle finishing. The end customer can easily install and replace each handle thanks to the special pressure mechanism, enjoying chromatic and material combinations between the tap and the handles. In fact, the 11 finishes of SO handles can be individually chosen or combined for a unique style. Even thanks to the material finishings (wood and concrete effect), the tap gets a strong personality that stimulates touch and sight, allowing a full personalization and the creation of special moods and styles in the bathroom.



F3171ABS + S1LC + S2CE

LAVABO DOPPIO COMANDO





F3171BOR + S1OS + S2LC

Nata da uno studio delle modalità fruibili di un miscelatore tradizionale, l'innovativa versione monoforo doppio comando coniuga la praticità di un solo semplice gesto con l'esigenza di avere sempre l'acqua alla temperatura desiderata, per un comfort e una semplicità di utilizzo senza eguali.

La vocazione green si trova nella canna che, con un diametro di 10 mm, limita la portata di erogazione dell'acqua soddisfacendo al contempo le esigenze di utilizzo quotidiane.

L'elemento che contraddistingue l'intera collezione è il miscelatore doppio comando, la cui funzione è ben identificata dalla dimensione e dalla posizione delle manopole. A sinistra la manopola più piccola e alta, serve per regolare la temperatura e mantenerla preimpostata su quella desiderata; a destra, quella più grande e bassa per aprire e regolare il flusso.



F3171ABS + S1LS + S2LS

Conceived after analysing the functions of a traditional mixer, our innovative single-hole mixer with double control combines the comfort of a simple gesture with the need of enjoying the most suitable temperature at all times.

The green soul of SO is in the spout, that saves water thanks to its $\varnothing 10\text{mm}$ without preventing the consumer from enjoying the nice flow.

The double control mixer is the key figure of our entire collection and stands out for its dimensions and the position of the knobs.

On the left, the smaller and taller handle sets the water temperature; on the right, the larger and shorter one regulates the water flow.

LAVABO DOPPIO COMANDO



F3171A



F3171B

+

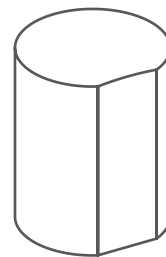

S1

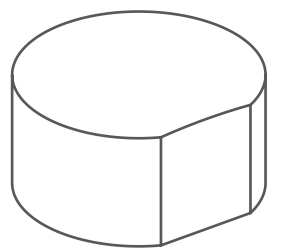

S2

HANDLES



F3191DSN + S4NS





F3191COS + S40S



F3191A



F3191B



F3191C



F3191D

All'interno della gamma SO è disponibile una serie di sofisticati miscelatori lavabo tre fori da appoggio creata per soddisfare la continua evoluzione sia delle dinamiche del design contemporaneo sia delle molteplici esigenze di installazione. Si sviluppa in differenti versioni grazie ai 4 modelli di canna che donano al prodotto identità diverse e lo rendono perfetto per qualsiasi ambiente bagno.

Le canne A e B, grazie al loro stile essenziale, richiamano le forme del miscelatore doppio comando, quelle C e D, con la loro altezza maggiorata di 320 mm, lo rendono perfetto per l'installazione su lavabi a bacinella o a semi-incasso. Tutte le canne sono inoltre ruotabili, così da permetterne un orientamento ottimale rispetto alla tipologia di installazione ed ergonomico rispetto all'utilizzo.

In particolare il diametro super slim di 10 mm, proprio del modello A, estende anche alla versione tre fori performance uniche di risparmio idrico.

Inoltre i doppi comandi, separati e indipendenti, possono essere posizionati liberamente nello spazio, così da esaudire diverse esigenze di stile e garantire sempre una notevole fruibilità.

Non solo, le varie possibilità di abbinamento - total look o in contrasto - delle finiture stimolano la creatività dei progettisti più eclettici per dare vita ad ambienti unici.

Our SO range includes a series of sophisticated, three-hole wash basin mixers for the bathroom, made to meet the ever-growing evolution of contemporary design and variety of installation needs. Several versions of the same model can be created thanks to 4 spouts conferring different identities to the product for customized bathroom designs.

Spouts A and B, with their essential style, recall the shapes of the double control mixer; C and D, with their enhanced 320 mm height, are perfect for installation on bowl or semi-built-in basins. All the spouts are adjustable to find the ideal orientation based on the type of installation and ergonomics.

The super slim diameter of $\varnothing 10$ mm, typical of model A, makes the three-hole version a unique water-saving performer as well.

In addition, the double control mixers, separated and independent, will fit right in to meet a wide range of stylistic needs while guaranteeing top comfort of use.

But there is more: The several options in terms of finish combinations – in total look or in clashing colour – fosters the creativity of the most eclectic designers resulting in unique ambiances.

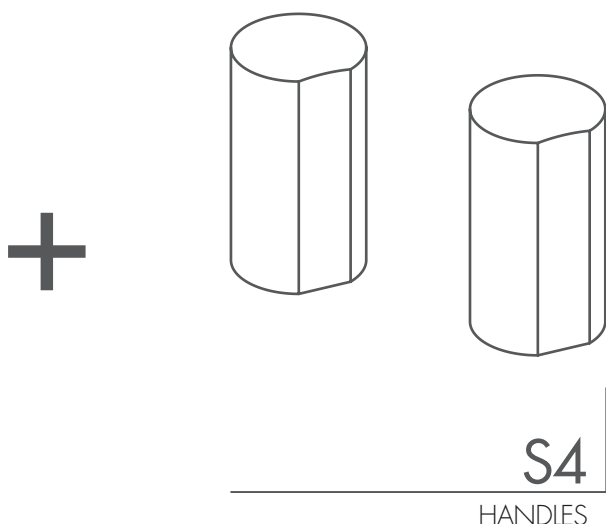
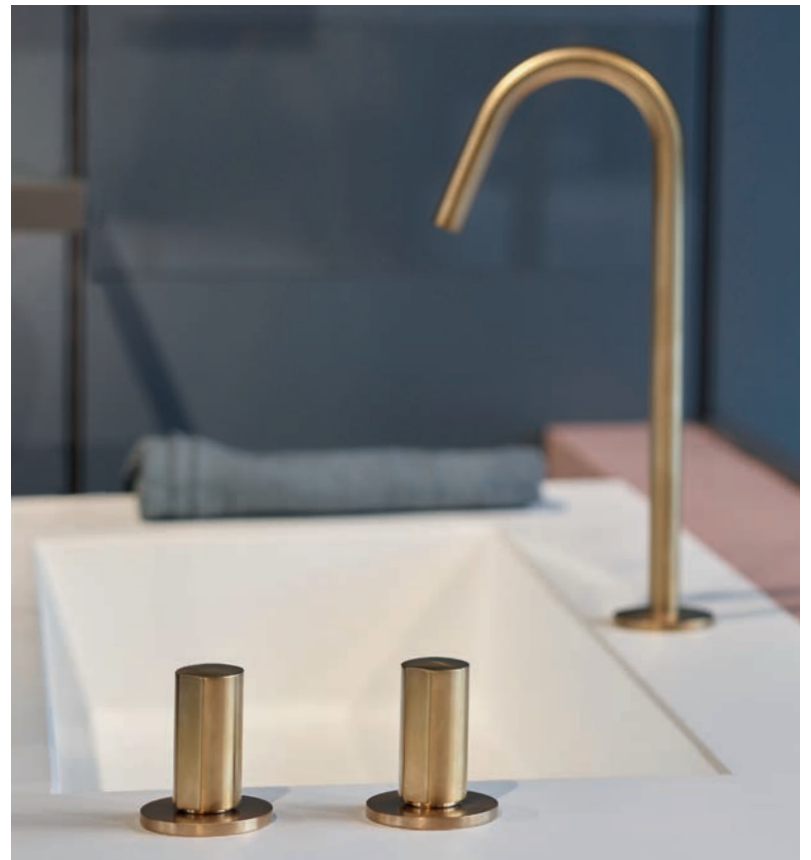



F3181CR + S3CR

L'essenziale versione monocomando completa l'offerta di miscelatori da appoggio, ponendosi quale elemento trasversale per chi vuole assicurarsi la praticità di utilizzo tipica di questo miscelatore.

Peculiarità distintiva è il taglio longitudinale della maniglia, che si estende verso il basso lungo tutto il corpo, donando slancio ed eleganza. Le due differenti altezze disponibili (240 mm e 290 mm) garantiscono l'installazione su qualunque tipologia di piano e lavabo e rendono il prodotto perfetto anche in caso di ristrutturazione o ampliamento dell'ambiente bagno.

Anche questa versione permette la possibilità di abbinamenti in contrasto, valorizzando così le capacità uniche di adattamento del modello che diventa protagonista degli spazi, grazie anche all'accattivante gioco tra superfici in finitura galvanica e quelle nelle texture materiche.



F3181/HNS + S3CE

The essential single-hole version completes the offer of our wash basin mixers as a transversal element for those who do not want to give up the comfort of use provided by this special mixer.

Its iconic look stands out for the longitudinal line of the handle, extending downwards along the entire body for a slim and refined look. The two different available heights (240 mm and 290 mm) make it fit for installation on any surface or basin and the perfect match also in case of renovating the bathroom.

This version can also be integrated into contrasting designs, thus enhancing its flexibility that turns it into the protagonist of the bathroom, also thanks to the attractive effect conferred by the galvanic finishing and materials textures.

MISCELATORE LAVABO



F3181/H



F3181

+

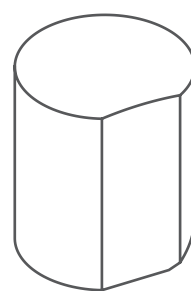

S3

HANDLE



F3171LX5SN + S2LS

MISCELATORE LAVABO A PARETE

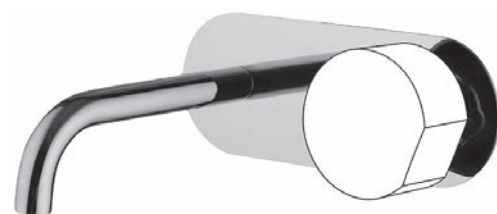

F3171X5

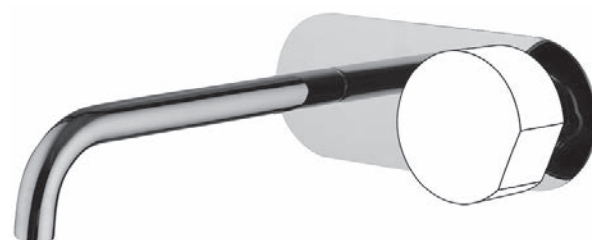

F3171LX5

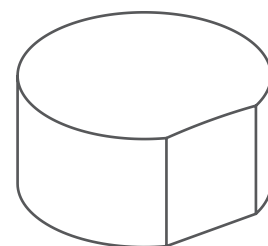

S2

HANDLE

Le versioni a parete della collezione SO, ben si sposano con le esigenze progettuali più raffinate.

Disponibile sia nella versione miscelatore sia in quella tre fori, la gamma offre differenti lunghezze della canna così da assicurare sempre una perfetta erogazione rispetto alla posizione del lavabo.

Anche in questa versione la maniglia singola o le maniglie doppie rappresentano l'elemento caratterizzante del prodotto e l'originale taglio consente estrema funzionalità.

Infine i corpi a incasso della collezione FIMABOXES rendono molto pratiche le operazioni di installazione e manutenzione, e garantiscono spessori minimi di incasso, tolleranza di installazione e una facilità di fruizione impassibile al trascorrere del tempo.



F3191L/5CS + S4LS

LAVABO A PARETE 3 FORI



F3191/5

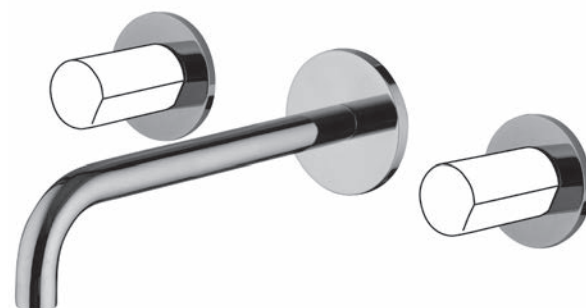

F3191L/5

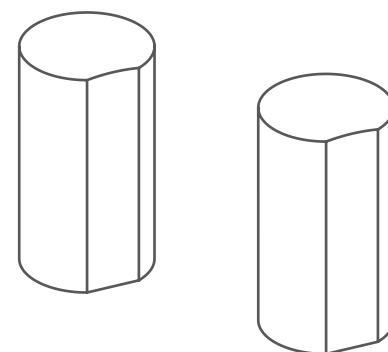

S4

HANDLES

The wall mounted versions of SO collection are the perfect choice for the most refined project needs.

Available in both single-hole and three-hole version, the range includes different spout lengths to guarantee the best flow regardless of the position of the basin.

Once again, the key figure of this product is represented by the single or double control handles, together with the unique "cut shape" ensuring the best comfort of use.

Finally, the built-in bodies of the FIMABOXES collection make installation and maintenance quick and easy, with their reduced plate thickness and installation tolerance to enjoy the utmost comfort of use and duration in time.

MISCELATORE VASCA PAVIMENTO



F3184/4CN + S2CE

La collezione SO si declina in un'ampia gamma di modelli per vasca e doccia. Grazie all'estetica accattivante e alla varietà di finiture disponibili sono ideali per valorizzare gli spazi wellness più raffinati, oltre ad essere estremamente funzionali.

Le soluzioni free-standing rendono la vasca protagonista collocandola al centro della scena, consentendo così installazioni libere all'interno dell'ambiente bagno. I modelli per doccia si adattano e integrano tutta la gamma dei corpi incasso per doccia di FIMA Carlo Frattini, rendendo la serie perfetta per l'inserimento sia in bagni di nuova costruzione sia in quelli già dotati di soluzioni a incasso FIMABOX, FIMAMULTIBOX, FIMASHOWERBOX e FIMATHERMBOX.

Quest'ultimo in particolare, grazie alla portata maggiorata e alle elevate prestazioni, rende SO una soluzione eccellente per i sistemi doccia più sofisticati e distintivi.

L'innovativo sistema a incasso THERMOBOX S permette l'installazione del miscelatore vasca a parete coordinabile con vasche e mini-piscine di grande prestigio.

The SO collection includes a wide range of shower and bath models that are able to enhance the look of the most refined bathrooms, thanks to their attractive design and the variety of available finishes – as well as being extremely functional.

The free-standing solutions put the bathtub under the spotlight, thus enabling free installation inside the bathroom.

The SO shower collection fits in the whole built-in box range of FIMA Carlo Frattini, making it the perfect choice for both new bathrooms and those already equipped with FIMABOX, FIMAMULTIBOX, FIMASHOWERBOX and FIMATHERMBOX built-in models.

FIMATHERMBOX, with its enhanced flow rate and performance, makes SO an outstanding solution for the most sophisticated and unique shower sets.

Our innovative built-in system THERMOBOX S allows to install the wall-mounted bath/shower mixer, perfectly suitable for matching to fancy bathtubs and mini-pools.



F3184/4

S2
HANDLE

GRUPPO INCASSO VASCA



F3179X2CS + S2NS



F3179X2

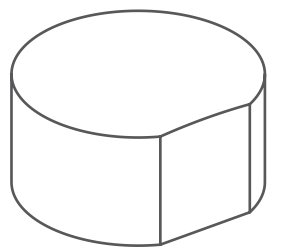
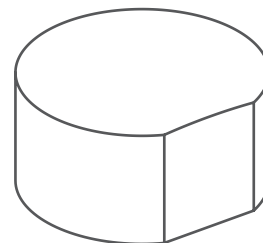

S2

HANDLES



F3178X3SN + S2NS

MISCELATORE DOCCIA TERMOSTATICO A PIÙ USCITE
 BUILT-IN THERMOSTATIC BATH/SHOWER MIXER WITH MORE OUTLETS



F3178X2



F3178X3



F3178X4

+

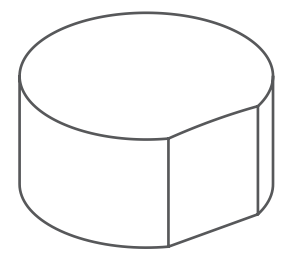

S2
 HANDLES



SO COLLECTION



F3171A



F3171B



F3181



F3181/H



F3191A



F3191B



F3191C



F3191D



F3171X5
fimabasin**box**



F3171LX5
fimabasin**box**



F3191/5



F3191L/5



F3172



F3182

SO COLLECTION



F3184/4



F3174



F3174/1



F3179X2
FIMATHERMBOX S



F3189X1
FIMABOX



F3189X2
FIMABOX



F3189X6
FIMAMULTIBOX



F3189X7
FIMAMULTIBOX



F3169X2
FIMASHOWERBOX



F3178X2
FIMATHERMBOX S



F3178X3
FIMATHERMBOX S



F3178X4
FIMATHERMBOX S



F3183X1
FIMATHERMBOX



F3183X2
FIMATHERMBOX



F3183X3
FIMATHERMBOX



F3183X4
FIMATHERMBOX

fima | CARLO FRATTINI®
r u b i n e t t e r i e

companies

ARBI ARREDOBAGNO

graphic project

FIMA CARLO FRATTINI

photo

WALTER ZERLA

follow me



WWW.FIMACF.COM



SPILLO

M A G A Z I N E

PROFILI SOTTILI
E FORME
MINIMALISTE

THIN OUTLINES AND
MINIMAL SHAPES

WWW.FIMACF.COM

fima | CARLO FRATTINI®
rubinetteria

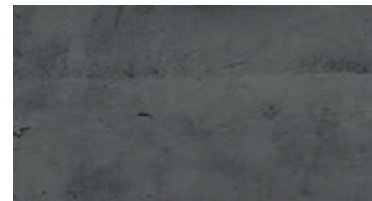

#PAVIMENTI FLOOR

LE SUPERFICI A TERRA SONO L'ELEMENTO DOMINANTE DEL BAGNO I CUI COLORI ED EFFETTI MATERICI NE DETERMINANO LO STILE.

FLOOR SURFACES ARE KEY TO BATHROOMS WHERE COLOR AND TEXTURE SET THE STYLE.



#SPILLOMOODBOARD

#COMPLEMENTI ACCESSORIES

LA TIPOLOGIA DI COMPLEMENTI SEGUE I TONI E I COLORI DELL'AMBIENTE IN CUI SONO INSERITI. L'ABBINAMENTO O IL CONTRASTO TRA DIFFERENTI MATERIALI NE DEFINISCE L'EFFETTO FINALE.

THE ACCESSORIES ALIGN WITH THE HUES AND COLORS OF THE SETTING. THE MATCHING COLORS OR CONTRASTING SHADES SET THE OVERALL EFFECT.

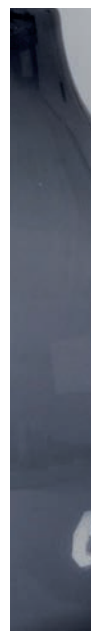
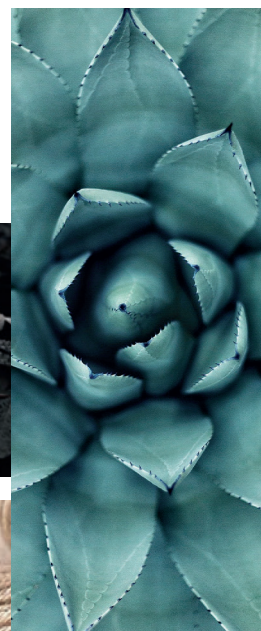
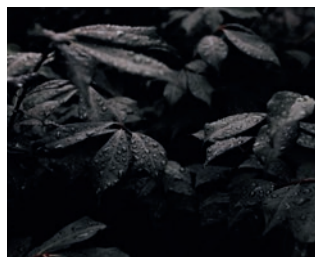

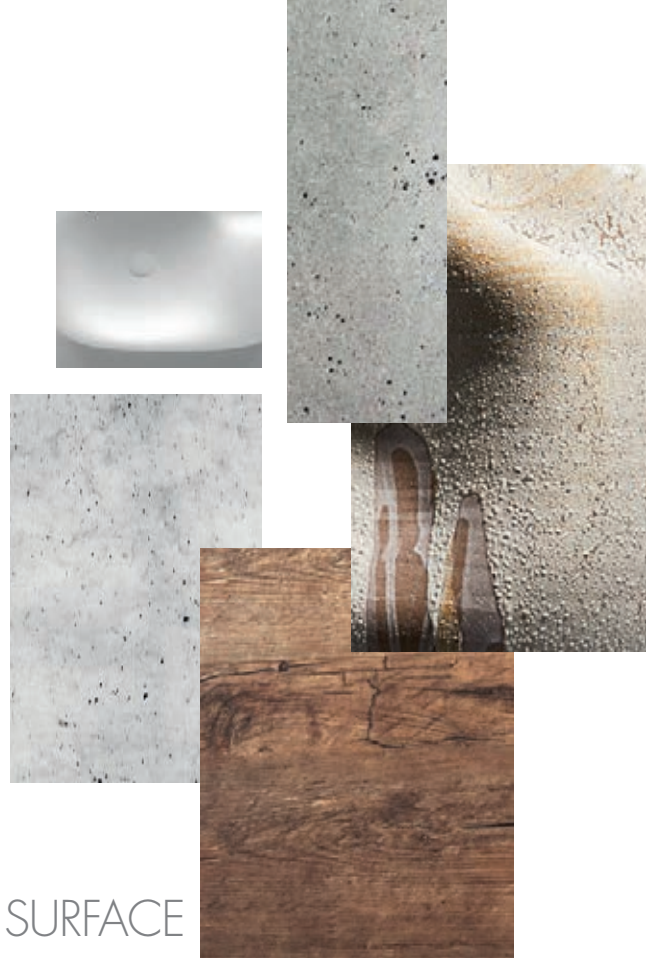
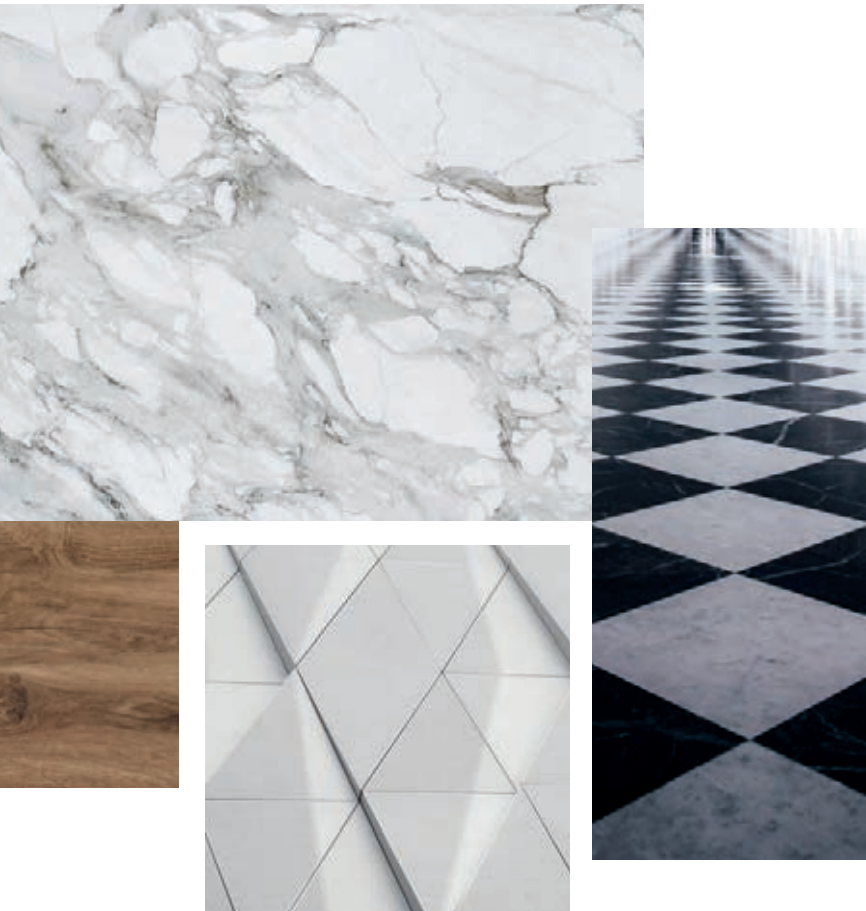

#PIANI SURFACE

I PIANI E LE SUPERFICI POSSONO SIA ESSERE COORDINATI AI MATERIALI SCELTI PER UNO STILE TOTAL LOOK, ELEGANTE E RAFFINATO, OPPURE IN CONTRASTO PER UN EFFETTO SCENOGRAFICO DI GRANDE CARATTERE.

COUNTERTOPS AND SURFACES CAN MATCH THE MATERIALS SELECTED FOR A TOTAL-LOOK STYLE OR FEATURE CONTRASTING SHADES FOR A BOLD LOOK.

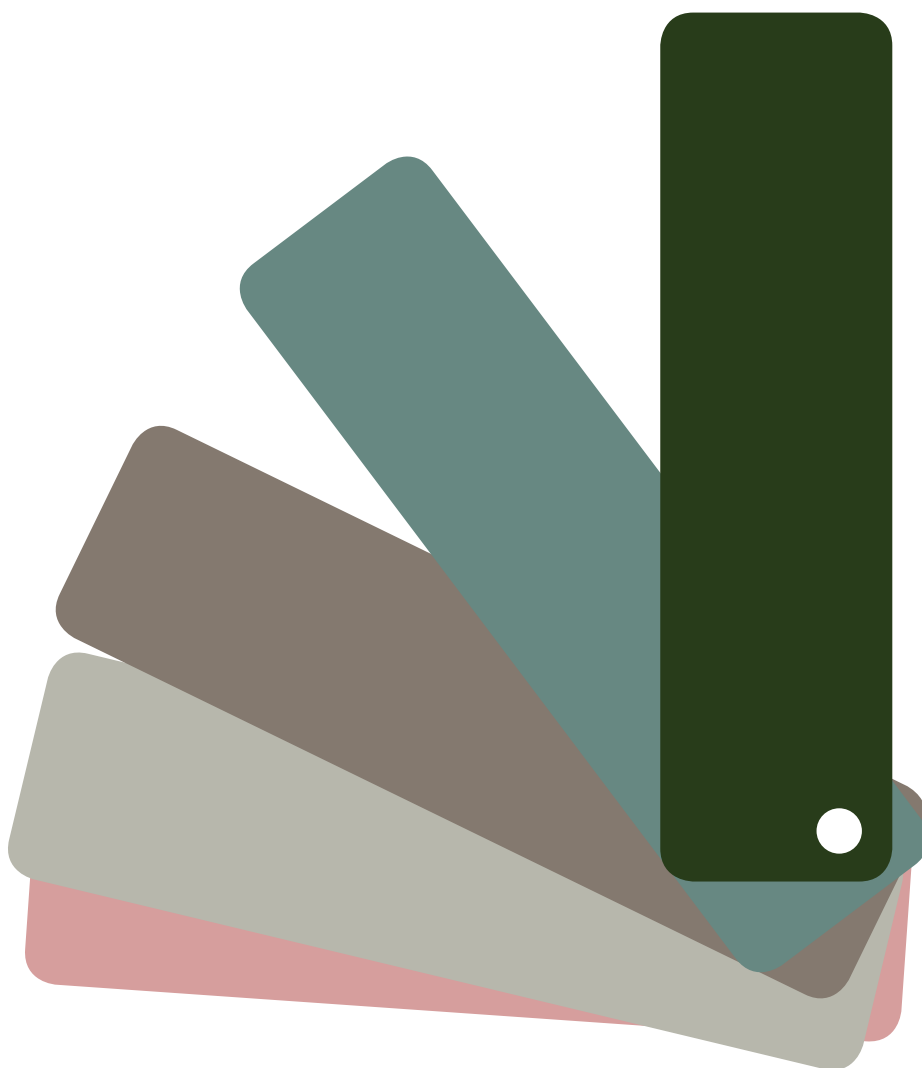
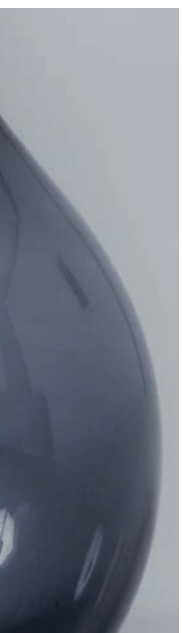

#COLORI COLORS

LA SCELTA DELLA PALETTE COLORI È IN GRADO DI RIVOLUZIONARE L'AMBIENTE. I TONI TENUI E LE TINTE PASTELLO DONANO ELEGANZA MENTRE LE TINTE PIÙ VIVIDE E CARICHE RENDONO UNICO E PERSONALE L'AMBIENTE BAGNO.

THE COLOR PALETTE CAN REVOLUTIONIZE THE BATHROOM. DELICATE HUES AND PASTEL SHADES ARE MORE GLAMOROUS WHILE BRIGHTER AND DEEPER TONES TURN THE STYLE IN A PERSONAL STATEMENT.



SPILOTECH

La purezza e l'essenzialità delle linee sono esaltate e impreziosite da raffinate texture, tre segni materici distinti che riproducono altrettante superfici tridimensionali con un gioco di rimandi dalla basetta alla leva, integrata armoniosamente nel corpo del miscelatore. Si tratta di: (V) Vertical, contraddistinta dal rigore geometrico di un poligono a 19 facce; (G) Godronata, che propone un effetto micro-diamantato dal mood fortemente industriale; (X) Cross il cui naming svela un'elegante e lussuosa superficie finemente sfaccettata, ispirata al prezioso diamante intagliato, ideale per ambienti sofisticati. Per rendere ancora più esclusiva e personale questa serie è possibile scegliere tra l'intera gamma delle finiture galvaniche – cromo, nickel spazzolato, cromo nero, cromo nero spazzolato, oro, oro spazzolato – e tra le tonalità bianco opaco e nero opaco. Spillo Tech è testimone di un modo diverso di progettare la semplicità, con una spiccata attenzione al dettaglio che trasforma un miscelatore dal design senza tempo in uno di tendenza.

The minimal shapes become iconic thanks to three different precious decorative elements that create an innovative visual language in the bathroom and reflect the identity and the style of the people who live it. The elegant and simple shapes are enhanced and enriched by stylish textures.

Three different material signs that reproduce three-dimensional surfaces with a suggestive connection between base and handle, harmoniously integrated in the mixer. They are: (V) Vertical, characterized by the geometric rigor of a 19 faces polygon; (G) Knurled, a micro-diamond effect with a strongly industrial mood; (X) Cross, whose naming reveals an elegant and luxurious faceted surface, inspired by the precious stone diamond, excellent for sophisticated environments.

A wide range of galvanic finishes make this collection even more exclusive and tailor made - chrome, black chrome, brushed nickel, brushed black chrome, gold, brushed gold - and white matt and black matt as well.

Spillo Tech is the result of a different way to design simplicity. The care for details transforms a timeless mixer into a trendy one.

V



G

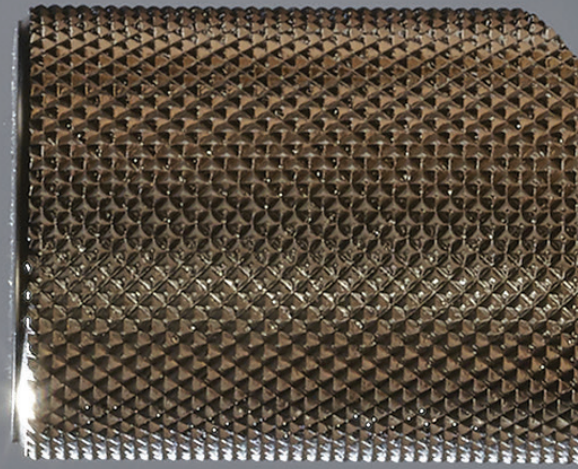

X



#CITY MATT



FINITURA: NERO OPACO

TEXTURE: V

COLORI: COLORI VERDE ARCADIA E TAPPEZZERIA

PIANO: CEMENTO

PAVIMENTO: LEGNO NOCE

L'effetto materico e setoso della finitura nero opaco si armonizza alla perfezione ai toni della tappezzeria e dei complementi mentre il contrasto con il piano in cemento enfatizza le forme del prodotto e le geometrie della maniglia V.

FINISH: BLACK MATT

TEXTURE: V

COLORS: ARCADIA GREEN COLORS AND UPHOLSTERY

SURFACE: CONCRETE

FLOOR: WALNUT WOOD

The texturized and silky effect of the matt black finish blends in with the colors of upholstery and accessories while the contrasting effect of the concrete top enhances the lines and geometry of the V-shaped handle.

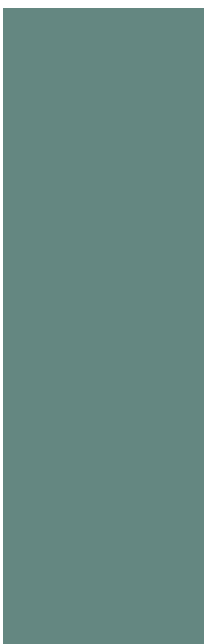
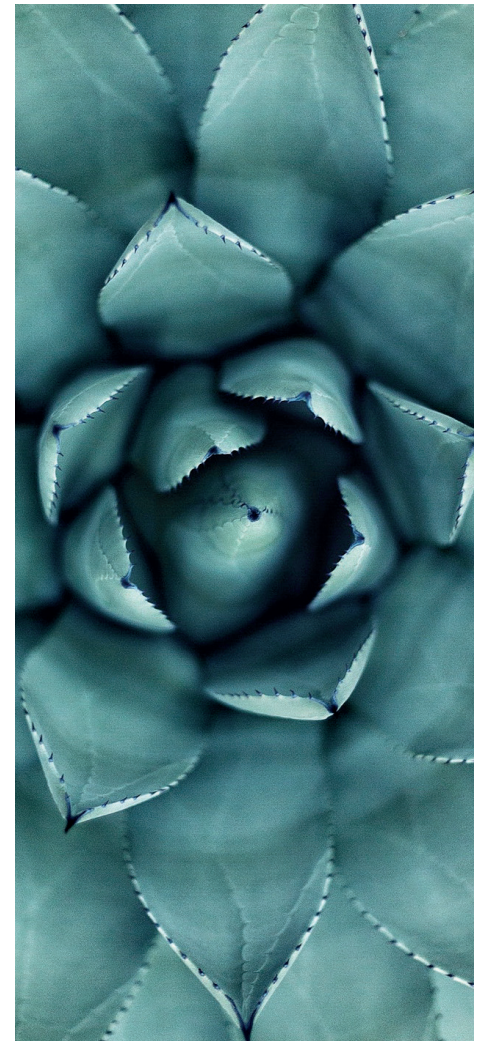
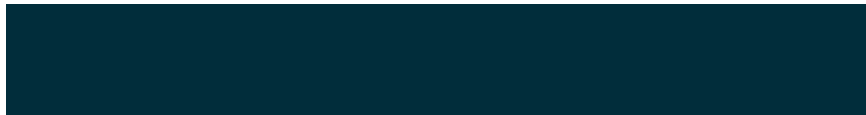



#DARK MANHATTAN



FINITURA: CROMO NERO

TEXTURE: X

COLORI: GRIGIO ANTRACITE E NERO

PIANO: MARMO BIANCO DI CARRARA

PAVIMENTO: MARMO BIANCO DI CARRARA

I riflessi raffinati e seducenti del cromo nero enfatizzano l'eleganza dei marmi e delle superfici scelte mentre l'inconfondibile lavorazione a X della maniglia dona grande forza e impatto agli ambienti.

FINISH: BLACK CHROME

TEXTURE: X

COLORS: ANTHRACITE GRAY AND BLACK

SURFACE: WHITE MARBLE

FLOOR: WHITE MARBLE

The elegant and seductive chrome-black highlights the precious marble surfaces while the unique X-patterned handle confers a bold touch to the entire room.

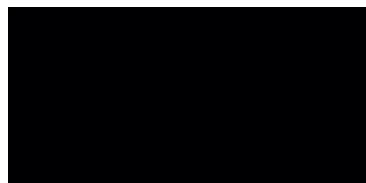
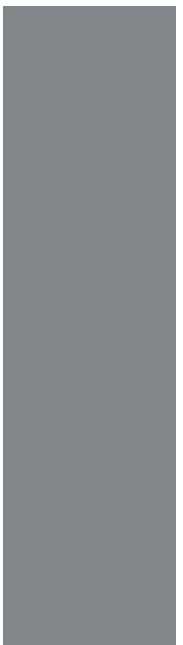
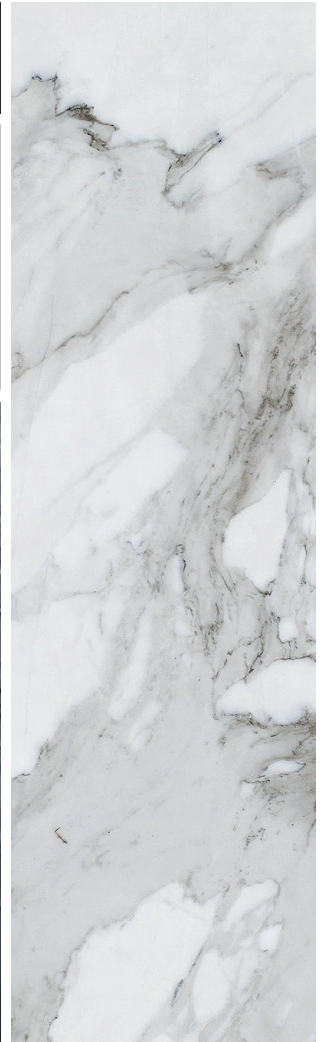



#INDUSTRIAL EPOQUE

FINITURA: ORO SPAZZOLATO

TEXTURE: G

COLORI: COLORI CALDI E TAPPEZZERIA

PIANO: CEMENTO

PAVIMENTO: RESINA

La finitura oro spazzolato, realizzata attraverso la spazzolatura manuale di uno strato di oro a 24K, abbinata alla lavorazione dal carattere industriale della maniglia rendono gli spazi estremamente attuali e di tendenza. Una finitura distintiva che conquista la scena se abbinata a complementi e arredi delle stesse tonalità.

FINISH: BRUSHED GOLD

TEXTURE: G

COLORS: WARM COLORS AND UPHOLSTERY

SURFACE: CONCRETE

FLOOR: RESIN

The brushed-gold finish, handmade with a layer of 24 carat gold and combined with the industrial style of the lever, adds to a modern and trendy look. A refined finish for a wow effect when matched to equally luxurious accessories and interior decorations.

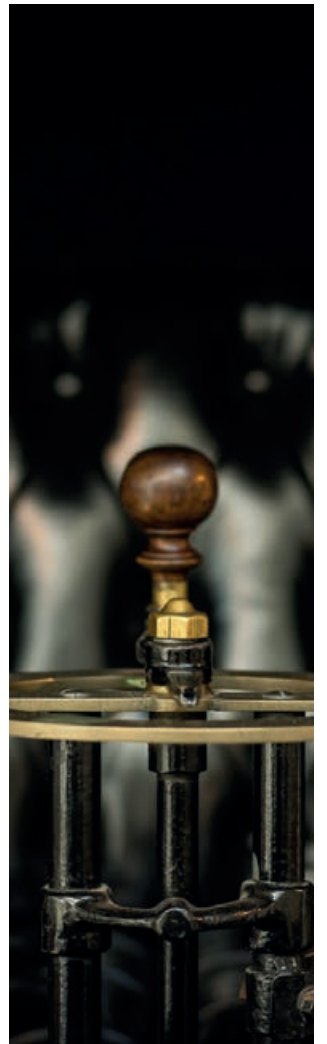
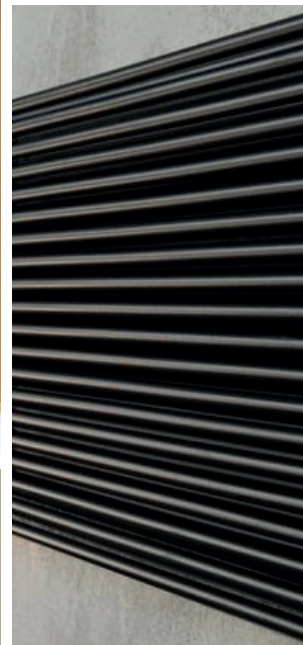
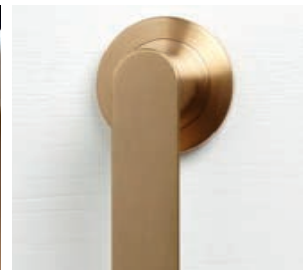





SPILOUP

Spillo Up si caratterizza per i suoi profili sottili e una forma slanciata e minimalista che conferisce alla serie un carattere incisivo. La collezione presenta un profilo dal design assolutamente lineare che sembra plasmare lo scorrere continuo dell'acqua e che migliora la prestazione dei miscelatori in termini di erogazione.

Una vasta gamma di miscelatore lavabo, disponibile in due misure differenti: Ø 45 mm con una cartuccia Ø 35 mm in dischi ceramici, predisposta per regolare la portata d'acqua e limitare la temperatura e la versione XS più sottile da Ø 35 mm, con una cartuccia molto piccola da Ø 25 mm che assicura la massima resa estetica senza compromettere comfort e funzionalità.

Un'ampia gamma di finiture rende questa serie ancora più esclusiva: cromo, nickel spazzolato, cromo nero, cromo nero spazzolato, oro, oro spazzolato, bronzo, rame antico, bianco opaco e nero opaco.



Spillo UP is featured by thin outlines and a slim shape that gives the collection a biting aspect for a never-ending iconic product. The collection shows linear shapes, following the continuous flow of water and improving the performance of products in distributing water.

Wide range of wash basin mixers, available in two different versions: Ø 45 mm with Ø35 mm ceramic disk cartridge, with water flow and temperature control, and the slimmer Ø 35 mm XS version, with an even smaller and highly performing Ø 25 mm cartridge for a classy yet comfortable and convenient item.

A wide range of finishes make this collection even more exclusive - chrome, black chrome, brushed nickel, brushed black chrome, gold, brushed gold, bronze, old copper, white matt and black matt.

SPILOUP XS
Ø35



Ø45

SPILOUP

#NORDIC WAVES



FINITURA: BIANCO OPACO

COLORI: VERDE SALVIA E TAPPEZZERIA FLOREALE

PIANO: ESSENZA ROVERE

PAVIMENTO: TEAK

Le tonalità del bianco opaco donano all'ambiente bagno un effetto etereo e rilassante quando abbinato a nuance e superfici naturali. La pulizia formale dei complementi è valorizzata dalle geometrie pulite e lineari del prodotto che creano un perfetto mood scandinavo.

FINISH: WHITE MATT

COLORS: SAGE GREEN AND FLORAL UPHOLSTERY

SURFACE: WOOD ESSENCE

FLOOR: TEAK WOOD

The matt white hues turn the bathroom into an ethereal and relaxing area when combined with natural nuances and spaces. The formal minimalism of the accessories is enhanced by essential and clean geometrics to create an authentic Scandinavia look.

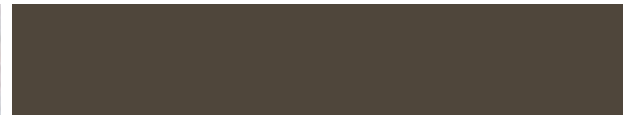
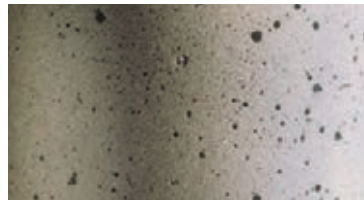



#MINIMAL RAW



FINITURA: CROMO NERO SPAZZOLATO

COLORI: SCALA DI GRIGI

PIANO: CEMENTO

PAVIMENTO: GRES PORCELLANATO GRIGIO

L'effetto materico e accattivante del cromo nero spazzolato evoca atmosfere industriali e senza tempo. Lo stile minimal del miscelatore enfatizza gli spazi e rende raffinate ed eleganti le superfici scelte.

FINISH: BRUSHED BLACK CHROME

COLORS: GREYSCALE

SURFACE: CONCRETE

FLOOR: GREY GRES PORCELLANATO

The texturized and winning effect of brushed-chrome black evokes timeless industrial atmospheres. The minimal style of the mixer emphasizes the spaces while conferring elegance and glamour to the surfaces.

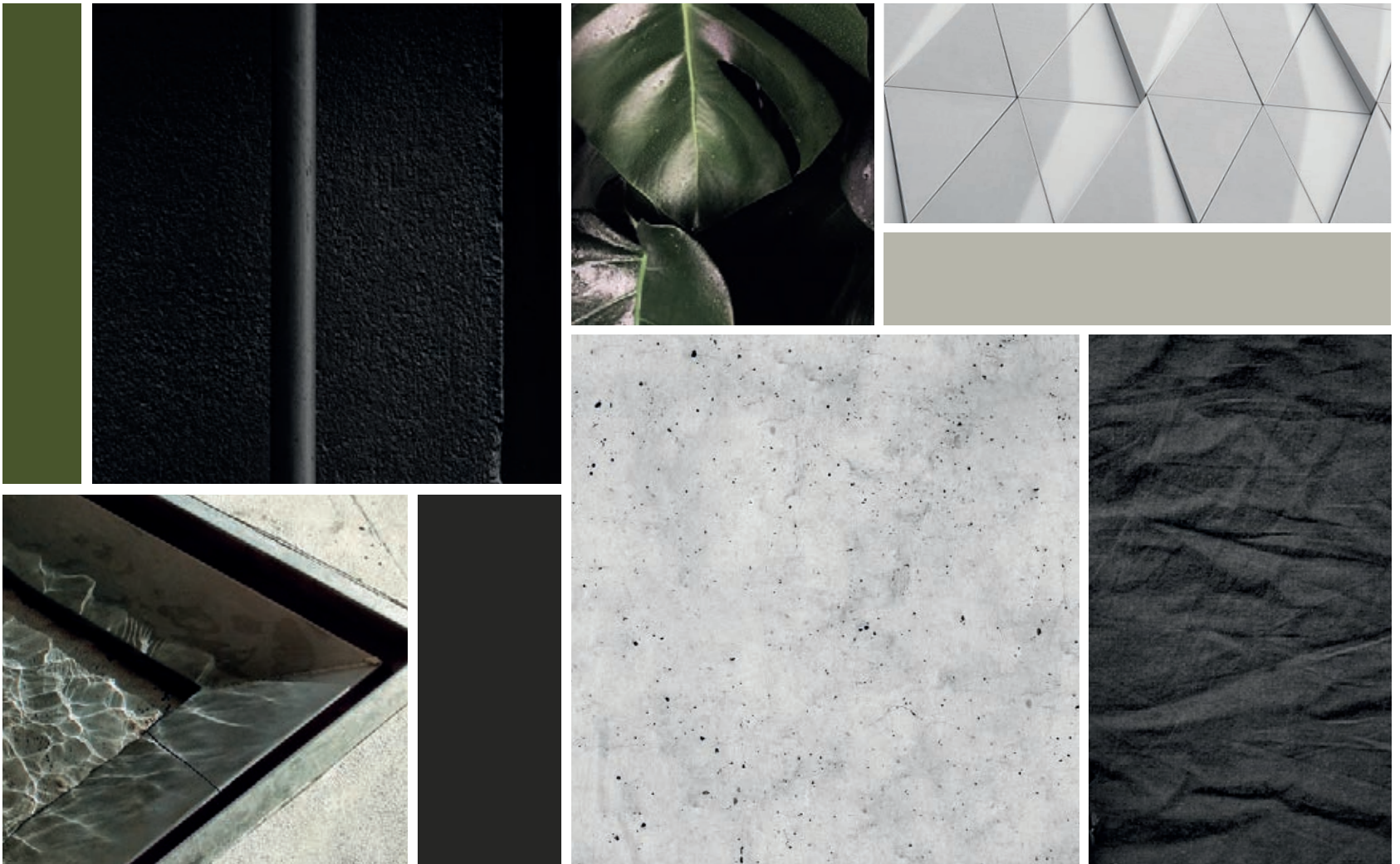



#GLAMOUR ROSE



FINITURA: ORO

COLORI: ROSA ANTICO E TAPPEZZERIA

PIANO: CORIAN

PAVIMENTO: MARMO LUCIDO BIANCO DI CARRARA

I riflessi lucenti e inconfondibili del rivestimento in oro a 24 k donano preziosità e stile all'ambiente. La scelta dei toni del rosa e delle superfici chiare conferisce un aspetto glam a un bagno che non si distingue per la sua esclusività.

FINISH: GOLD

COLORS: SOFT PINK AND UPHOLSTERY

SURFACE: CORIAN

FLOOR: WHITE MARBLE

The unmistakable brightness of the 24 carat-gold coating is a touch of preciousness and style. The pink hues and light-colored surfaces turn a plain bathroom into a glam room.







SPILOSTEEL

AISI 316L

L'eccellenza dell'acciaio inox e un design essenziale: queste le due prerogative di Spillo Steel, una collezione completa e articolata di miscelatori per il bagno e componenti doccia caratterizzata da forme slanciate e da un carattere incisivo.

Un prodotto che coniuga uno stile senza tempo con un materiale dall'anima green: l'acciaio inox, infatti, ha conquistato una propria identità nel settore grazie alle sue proprietà intrinseche di inalterabilità nel tempo, igienicità ed eco-sostenibilità.

La resistenza alla corrosione e la durezza del materiale rappresentano la garanzia di qualità della serie e ne assicurano la durata nel tempo grazie a un'inerzia nei confronti degli agenti esterni e alla resistenza all'azione di detersivi e solventi, rendendola anche igienica e facile da pulire. Oltre a una naturale inalterabilità alle sollecitazioni, l'acciaio inox AISI 316L utilizzato per questa serie non contiene metalli nocivi, non necessita di verniciature o rivestimenti superficiali dannosi per l'ambiente, è atossico e riciclabile.

Per tutte queste peculiarità è ideale per la realizzazione di rubinetti che sposano le esigenze di design con le normative vigenti in tema di sicurezza per la salute e l'ambiente.

The supremacy of stainless steel and an essential design: these features are key to Spillo Steel, a rich and complete collection of bathroom mixers and shower elements characterized by slender silhouettes and a bold attitude.

The perfect combination between design and environmental sustainability, a product that combines a timeless style with essential green materials. The stainless steel has acquired its own identity in the industry thanks to its intrinsic features of inalterability over time, cleanliness and environmental friendliness. Corrosion resistance and material hardness represent the guarantee of quality of the series and ensure it is long-lasting, thanks to its endurance towards external agents and its resistance to detergents and solvents, making it hygienic and easy to clean. In addition to its natural inalterability to stresses, AISI 316L stainless steel does not contain toxic metals, does not need any environmentally harmful surface coatings and it is recyclable. Thanks to all these unique qualities it is suitable for manufacturing taps that combine in a perfect balance the need for design with the existing safety legislation for health and environment.

GREEN MATERIALS



#STEEL REFLECTIONS

FINITURA: ACCIAIO INOX
COLORI: GRIGIO E TAPPEZZERIA
PIANO: LAMINATO SPAZZOLATO
PAVIMENTO: RESINA GRIGIO

Le tonalità e gli effetti materici dell'acciaio inox AISI 316L spiccano all'interno di un ambiente in cui colori, grafiche, superfici e complementi creano un suggestivo effetto armonico. La caratteristiche di questo materiale, inalterabile al trascorrere del tempo, lo rendono perfetto per ambienti all'aperto o all'interno di aree wellness di grande prestigio.

FINISH: STAINLESS STEEL
COLORS: GREY AND UPHOLSTERY
SURFACE: BRUSHED LAMINATE
FLOOR: GREY RESIN

The hues and textured effect of AISI 316L stainless steel stand no comparison when it comes to an ambient where colors, graphics, surfaces and accessories are harmoniously blended together. This special material, standing tall to the test of time, is the ultimate solution for exclusive and refined indoor or outdoor spas.

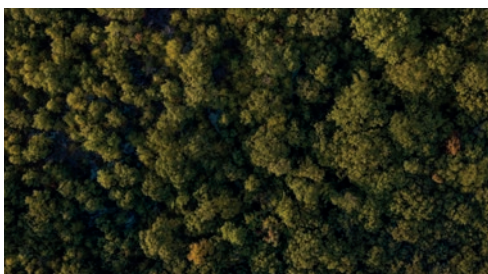
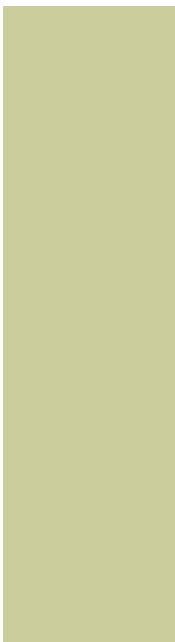

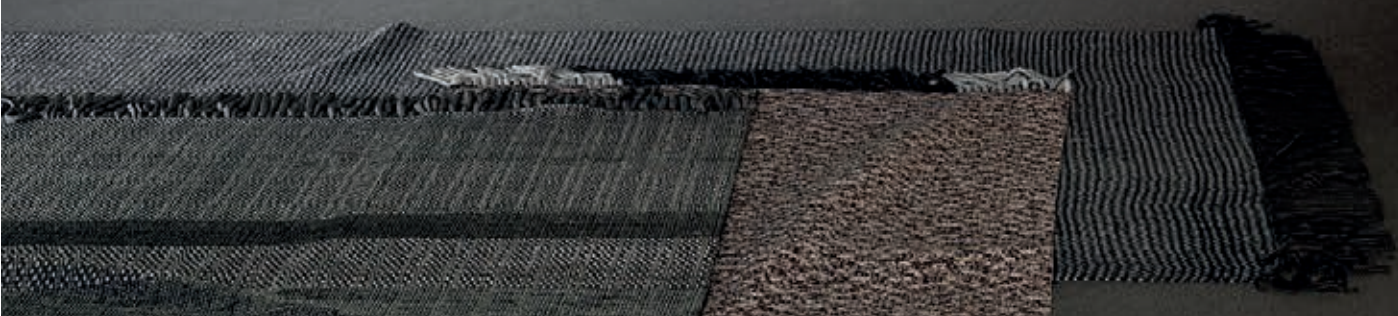

SPILLO TECH COLLECTION

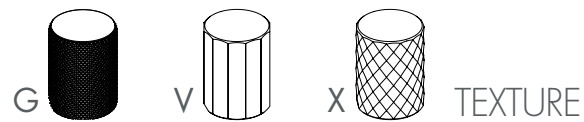

F3031XSX



F3031LXSX



F3031/HXSX



F3032XSX



F3051X5X
FIMABASINBOX



F3051VLX5X
FIMABASINBOX



F3051X8X
FIMABASINBOX



F3051X9X
FIMABASINBOX



F3031/PX



F3034/6X



F3044X



F3044/1X



F3034X



F3035X



F3035/2X



F3049X2X
FIMASHOWERBOX



F3033/1X



F3039X1X
FIMABOX



F3039X2X
FIMABOX



F3039X6X
FIMAMULTIBOX



SPILLO UP COLLECTION



F3031



F3031XS



F3031LXS



F3031/HXS



F3032XS



F3041



F3051X5
FIMABASINBOX



F3051X8
FIMABASINBOX



F3051X9
FIMABASINBOX



F3031/P



F3034/6



F3044



F3044/1



F3034



F3035



F3035/2



F3049X2
FIMASHOWERBOX



F3033/1



F3039X1
FIMABOX



F3039X2
FIMABOX



F3039X6
FIMAMULTIBOX

SPILLO STEEL COLLECTION



F3071INOX



F3071LINOX



F3071/HINOX



F3072INOX



F3081X5INOX
FIMAbasinbox



F3081X8INOX
FIMAbasinbox



F3081X9INOX
FIMAbasinbox



F3071/PINOX



F3074INOX



F3075INOX



F3079X2INOX
FIMAbOX



F3079X6INOX
FIMAmultiBOX



F3089X1INOX
FIMathermbox



F3089X2INOX
FIMathermbox



F3089X3INOX
FIMathermbox



F3089X4INOX
FIMathermbox



F3083X1INOX
FIMathermbox



F3083X2INOX
FIMathermbox



F3083X3INOX
FIMathermbox



F3083X4INOX
FIMathermbox

fima | CARLO FRATTINI®
r u b i n e t t e r i e

follow me



WWW.FIMACF.COM



texture
collection

Texture Collection.

Design MENEGHELLO PAOLELLI ASSOCIATI

fima | CARLO FRATTINI®
rubinetterie
AQUA CODE

texture
collection

DESIGN E LUSO
PER INFINITE
POSSIBILITÀ DI
PERSONALIZZAZIONE

*DESIGN AND LUXURY FOR ENDLESS
POSSIBILITY OF CUSTOMIZATION*

*ДИЗАЙН И РОСКОШЬ ДЛЯ НЕОГРАНИЧЕННЫХ
ВОЗМОЖНОСТЕЙ ИНДИВИДУАЛИЗАЦИИ*

Contents

Intro.

4. IL VALORE DEL BRAND

The value of the brand | Значение бренда

8. IL RACCONTO PROGETTUALE

Design philosophy | Дизайн Философия

10. L'IDEA DIETRO IL CATALOGO

The idea behind this catalogue | Идея данного каталога

Mood.

14. NEW YORK EXECUTIVE

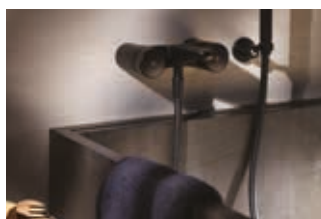

18. TASTE OF PROVENCE



22. MARBLE PURITY



26. ELEGANT CONTRAST



30. SCANDINAVIAN ATTITUDE



34. RETRO DELIGHTS



38. INDUSTRIAL ESSENTIALS



42. LUXURY EXTRAVAGANCE

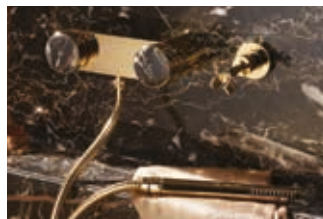

Appendix.

46. TEXTURE COLLECTION: COME FUNZIONA

Texture Collection: how it works | Texture Collection: как функционирует



Il valore del brand

The value of the brand | Значение бренда

Tecnologia, estetica ed elevate prestazioni: FIMA Carlo Frattini propone da oltre 50 anni rubinetteria di altissima qualità destinata a durare nel tempo e capace di dare valore aggiunto ad ogni progetto. L'Azienda ha assunto negli anni un taglio innovativo ed in continua evoluzione, grazie alla creatività, al design e alle nuove tecnologie, che differenziano le sue collezioni. FIMA, infatti, si rinnova costantemente, come dimostrano l'alto livello progettuale e qualitativo della produzione, i continui investimenti in ricerca, la forte espansione nazionale e internazionale, la professionalità del team aziendale. Questo atteggiamento ha portato l'Azienda ad interpretare e anticipare le esigenze contemporanee e future del mercato, proponendo prodotti all'avanguardia per design e tecnologia, curati singolarmente in ogni dettaglio.

Technology, aesthetics and performance: FIMA Carlo Frattini has been offering for more than 50 years high quality taps designed to last over time and able to give added value to each project. Over the years the Company has taken an innovative and evolving feature, thanks to creativity, design and new technologies, which differentiate its collections. FIMA, in fact, is being continually renewed as shown by the high level of design and the quality of the production, the continuous investment in research, the strong national and international expansion, the professionalism of the corporate team. This attitude has led the company to understand and anticipate the contemporary and future market needs, offering advanced products for design and technology, which are treated individually in every detail.

Технология, эстетика и качественный сервис клиента: FIMA Carlo Frattini уже более 50 лет предлагает смесители самого высокого качества, независимые от времени и приносящие дополнительную ценность в любой проект. Компания пронесла через годы свои инновации и постоянно эволюционирует, благодаря креативности, дизайну, и новым технологиям, которые отличают наши коллекции. FIMA, постоянно обновляется, как демонстрируют высокий проектный уровень и качество продукции, постоянные инвестиции в исследования, активное расширение как национального, так и международных рынков, профессионализм сотрудников компании. В этом смысле компания видит своё назначение - передать и опередить современные и будущие запросы рынка, предлагая авангардные продукты как по дизайну так и по технологиями, произведённые с вниманием к каждой детали.

È qualità

It is quality | Качество

La produzione FIMA rappresenta la sintesi fra diversi elementi: design, tecnologia, innovazione - fino a sfiorare una cura artigianale verso il prodotto. La qualità è il comune denominatore, ed è così che questa gamma di prodotti dedicati al bagno parla un linguaggio di perfezione e affidabilità.

The production FIMA is the synthesis of different elements: design, technology, innovation - almost an handcrafted product. Quality is the common denominator, and that is how this range of products for the bathroom speaks a language of perfection and reliability.

Продукция FIMA представляет собой синтез различных элементов: дизайна, технологии, инноваций, производственных концепций. Но доминирующий показатель - всегда качество. Также и эта линейка продукции, посвящённая ванной комнате, говорит на языке совершенства и надёжности.





È servizio

It is service | Сервис

Il servizio FIMA è sinonimo di competenza, assistenza, alti standard qualitativi, eccellenza globale, supporto tecnico e collaborazione. Per questo il Centro Ricerca FIMA è all'avanguardia in sperimentazione, tecnologia e innovazione. Ogni mercato ha esigenze specifiche e i designer che collaborano con esso conoscono approfonditamente il mercato/il settore, dove a contare non sono solo i prodotti, ma soprattutto il livello di servizio che un'azienda è in grado di offrire.

FIMA service stands for competence, assistance, high quality standards, global excellence, technical support and collaboration. For this reason the FIMA Centre for Research is at the forefront in testing, technology and innovation. Each market has its specific needs and the designers who work with, have an in-depth knowledge of the market / business, where the main point is not just the product itself, but especially the level of service that a company is able to offer.

Возможность сервиса с точки зрения FIMA - синоним компетентности, помощи в обслуживании, несменных высоких стандартов, эталонов качества в целом, технической поддержки и сотрудничества. Неслучайно, Центр Исследований Fima находится в непрерывном движении между экспериментированием, технологиями и инновациями. Каждый рынок имеет особые потребности и дизайнеры, которые сотрудничают с Центром Исследований FIMA, хорошо знакомы с обзором профильного рынка, где, несомненно, оценивают продукцию, но прежде всего, уровень сервиса, который готова предложить компания.

È rispetto per l'ambiente

It is respect for the environment | С уважением к окружающей среде

Oggi, il termine “ricerca” integra il concetto di consapevolezza e rispetto per l'ambiente, etica e sostenibilità. FIMA Carlo Frattini utilizza nel proprio ciclo produttivo procedimenti innovativi che eliminano i componenti inquinanti e si avvale di materie prime nel rispetto delle normative più restrittive, come quelle richieste dai Ministeri della Salute di USA e Canada. Inoltre l'Azienda utilizza materiali riciclati e riciclabili con l'obiettivo di avere il minore impatto ambientale possibile, anche in fase di produzione. Riguardo al prodotto, sono state messe a punto soluzioni che possono regolare i consumi di acqua e di energia, attraverso flussi controllati di portata e temperatura.

Today the term “research” incorporates the concept of awareness and respect for the environment, ethics and sustainability. FIMA Carlo Frattini uses innovative procedures in its production cycle that eliminate polluting components and makes use of raw materials in compliance with the most restrictive norms, such as those required by the Ministries of Health of the US and Canada. In addition, the Company uses recycled and recyclable materials with the goal of having as little environmental impact as possible, even during production. Regarding the product, solutions have been developed which can reduce waste of water and energy, through controlled flows for quantity and temperature.

Сегодня, понятие «исследования» интегрируется с концептом осознания и уважения к окружающей среде, этики и поддержки. FIMA Carlo Frattini использует в производственном цикле инновационные процессы, которые исключают наличие вредных загрязняющих компонентов и использует сырьё в соответствии с самыми жёсткими нормативами, такими как стандарты Министерства Здравоохранения США и Канады. Кроме этого компания работает с вторично используемыми и биоразлагаемыми материалами с целью минимизировать воздействие на окружающую среду, даже на стадии производства. В отношении продукции, были предложены решения, которые позволяют регулировать расход воды и энергии, путём контроля напора воды и температуры.

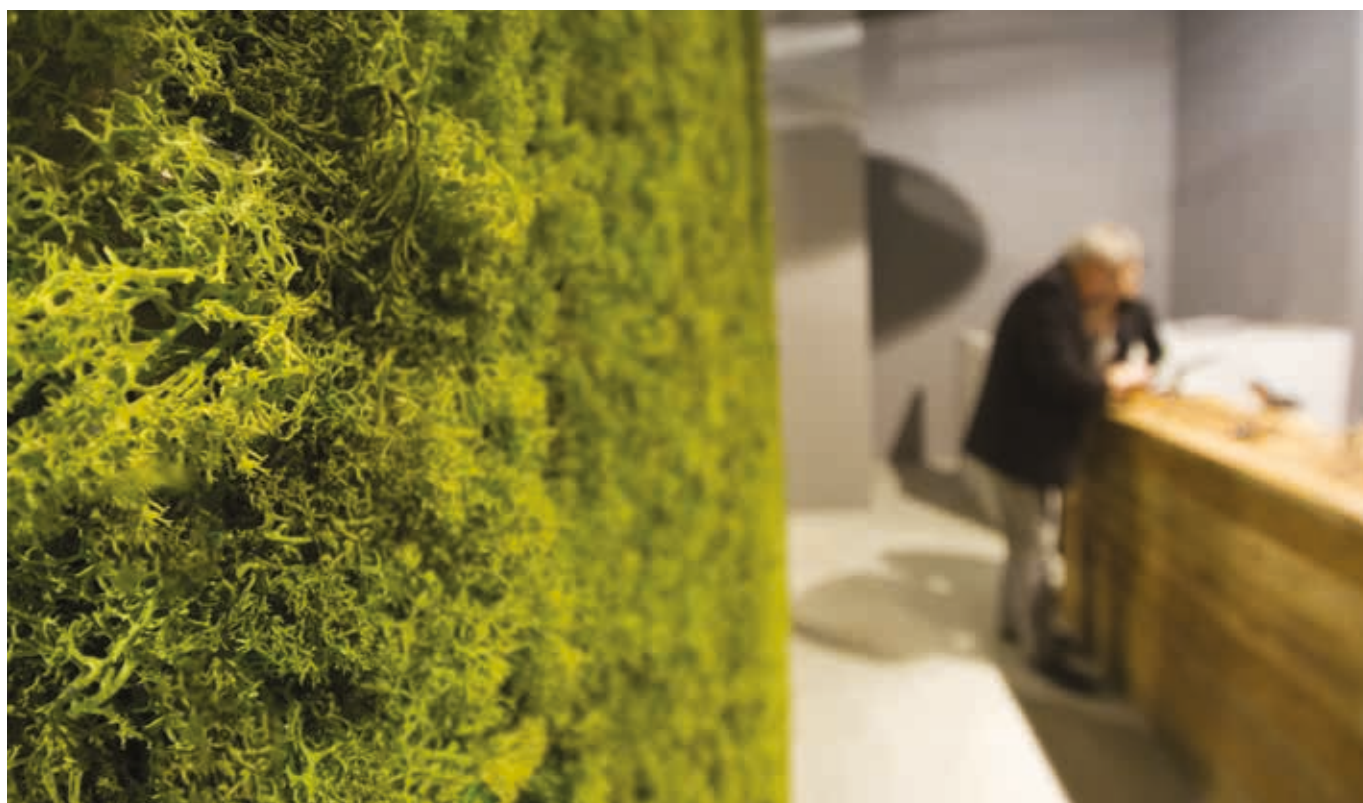

Il racconto progettuale

Design philosophy | Дизайн Философия Дизайн Философия

Minimalismo e décor per Texture Collection, il nuovo sistema completo di rubinetteria per l'ambiente bagno. Una proposta ideale per il settore contract che nasce dall'interpretazione del design come mezzo principe per manifestare stili e caratteri diversi e adattarsi al meglio ad ogni input progettuale. Questo concept trova massima espressione nelle inedite manopole intercambiabili, veri stilemi di Texture, con le quali è possibile ricreare look diversi, sempre ricercati e dal gusto contemporaneo, per bagni di grande carattere, capaci di rinnovarsi proprio come un cambio d'abito. Più in particolare, la versione lavabo di Texture Collection è caratterizzata da un sistema a tre fori composto da due manopole a base cilindrica, che uniscono tratti lineari a forme più fluide, ed una canna dai profili stondati in perfetta continuità stilistica con la morbidezza di tutta la linea. Cuore del progetto è la ricchezza delle finiture delle manopole, disponibili in tre varianti con segni distinti che ritraggono altrettante texture superficiali tridimensionali: (X) Cross il cui naming svela un'elegante superficie sfaccettata, ispirata alla preziosa pietra diamante, per ambienti sofisticati; (V) Vertical, contraddistinto dal rigore geometrico di un poligono a 19 facce; (H) Horizontal, che propone un effetto a righe orizzontali tridimensionali dal mood hi-tech.

La massima personalizzazione è assicurata anche dalla possibilità di poter scegliere tra 6 diversi top: cromato, bianco, nero, marmo bianco di carrara, marmo nero portoro ed oro, per originali combinazioni che raccontano di un nuovo senso estetico e creativo custom made. Texture Collection è una serie 100% Made in Italy, come tutta la produzione FIMA Carlo Frattini, che parte dalla scelta di materiali di primissima qualità e si completa nella minuziosa attenzione ai dettagli estetici e funzionali. Tutti i prodotti, infatti, vengono sottoposti ad un minuzioso controllo in ogni fase di lavorazione e sono progettati in modo da rispettare tutte le più rigide normative internazionali.

Minimalism and décor for Texture Collection, the new complete system of fittings for the bathroom. An ideal proposal for the contract sector that arises from the interpretation of design as a means of expression of different natures and styles to best suit every design input. This concept is most effectively expressed through the interchangeable handles, real stylistic elements of Texture, with which you can create different looks, always sophisticated and contemporary taste, for bathrooms of great character, capable of renewing themselves just like a change of clothes. More particularly, the version of washbasin Texture Collection is characterized by a system with three holes composed of two knobs with cylindrical base, which combine the linear stretches to more fluid forms, and a rounded profiles spout in perfect stylistic continuity with the softness of the whole line. The heart of the project is the richness of the knobs finishings, available in three variants with distinct signs depicting tridimensional surface textures: (X) Cross whose naming reveals an elegant faceted surface, inspired by the precious stone diamond, for sophisticated environments; (V) Vertical, characterized by geometric rigor of a polygon with 19 faces; (H) Horizontal, offering a tridimensional effect with horizontal stripes of hi-tech mood.

A further personalization is ensured by the possibility to choose from 6 different handle tops: chrome, white, black, white Carrara marble, black Portoro marble and gold, for original combinations of a new aesthetic and a creative custom made. Texture Collection is a line 100% Made in Italy, as all production FIMA Carlo Frattini, starting from the choice of the highest quality materials ending up with the meticulous attention to the aesthetic and functional details. All the products, in fact, are subjected to a detailed control at every stage of production and are designed in order to comply with all the strictest international standards.

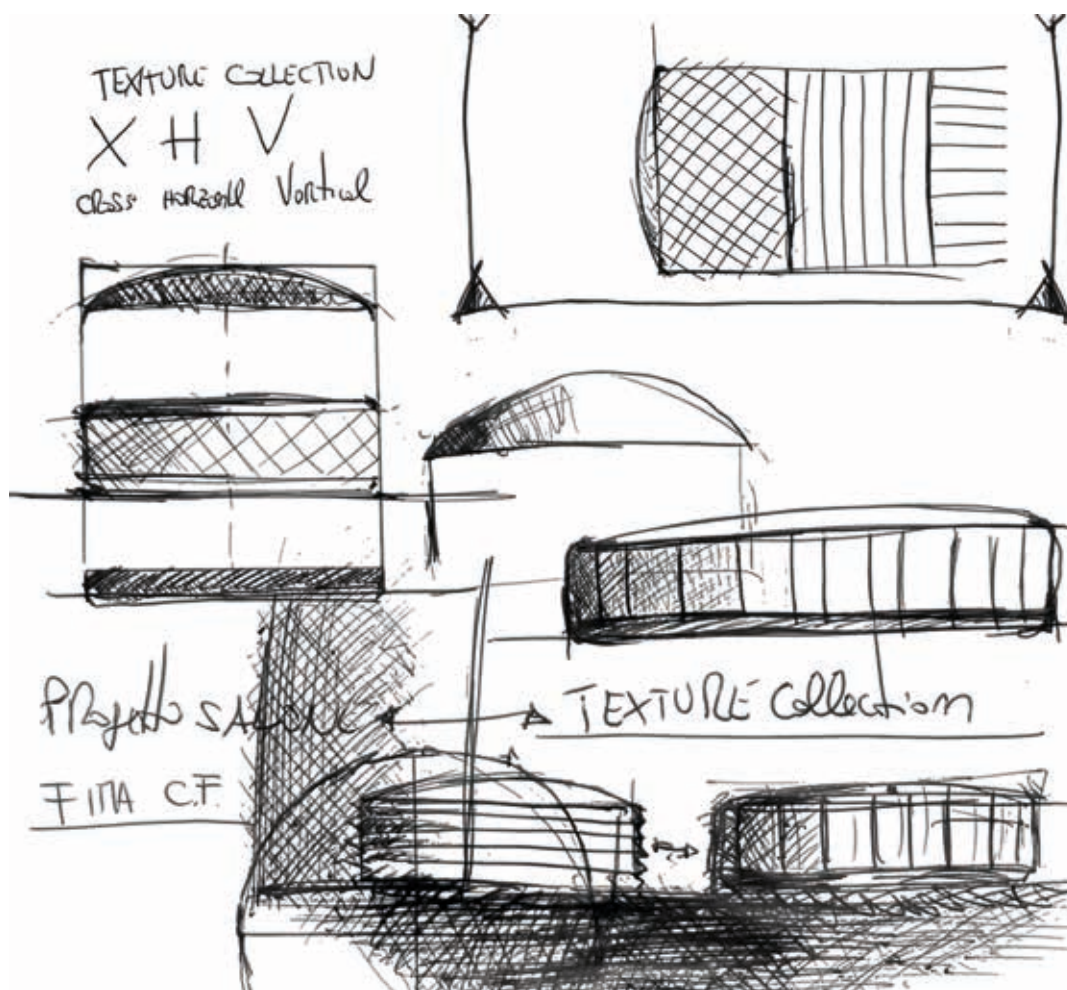

Это предложение идеально подходит для современного дизайна, который возникает в связи с толкованием дизайна как средства выражения различных тенденций и стилей, чтобы наилучшим образом удовлетворить любую дизайнерскую идею. Эта концепция находит свое наибольшее выражение в необычных сменных ручках серии Texture Collection, с помощью которых можно создавать различные стили ванной комнаты и менять его в соответствии с вашими желаниями и изменившимися вкусами, также легко как вы меняете одежду. В частности, смеситель коллекции Texture предназначен для системы с тремя отверстиями, снабженный двумя ручками с цилиндрическим основанием, которые имея плавные формы поддерживают мягкость свойственную стилистике всей серии. Изюминкой проекта несомненно является богатство отделки ручек, доступных в трех вариантах. Для отображения различных трехмерных текстур поверхности использовали следующие символы: (X) Исходя из названия, эта модель предполагает элегантную граненную поверхность, на создание которой вдохновили драгоценные камни – алмазы. (V) Вертикаль, отличается геометрической строгостью многоугольника с 19 сторонами; (H) Горизонталь, который предлагает трехмерный эффект с горизонтальными полосами в стиле хай-тек.

Максимальная индивидуализация гарантируется также благодаря возможности выбрать между 6 различными верхними накладками: хромированный, белый, чёрный, мрамор каррара белый, мрамор порторо чёрный и золото, для оригинальных комбинаций, которые придают новый эстетический смысл и индивидуальную креативность. Texture Collection на 100% Made in Italy, как и вся продукция FIMA Carlo Frattini, отправной точкой для которой является выбор материалов самого высокого качества и тщательное внимание к деталям, как эстетическим, так и функциональным. Действительно, вся продукция проходит тщательный контроль на каждой стадии и спроектирована в соответствии с требованиями самых жёстких международных нормативов.



L'idea dietro il catalogo

The idea behind this catalogue | Идея данного каталога

Il catalogo vuole fornire una palette di materiali, finiture e complementi di arredo che idealmente si possano abbinare ad alcune delle moltissime combinazioni possibili con il sistema di rubinetterie Texture Collection. Una proposta estremamente ricca e variegata che si propone di suggerire alcuni accostamenti, senza però pensare di poter esaurire con questo il racconto degli infiniti modi di utilizzo della Collezione. Gli abbinamenti, grazie alle 72 combinazioni possibili tra finiture e materiali in questa gamma, sono infatti infiniti e in grado di rispecchiare il gusto di ciascuno.

The goal of the catalogue is to provide a range of materials, finishes and furnishings that can be ideally combined with some of the many possible combinations of the Texture Collection. An extremely rich and varied proposal giving the possibility to create an infinite number of combinations using the collection. Thanks to the 72 possible combinations of finishes and materials in this range, the combinations are in fact infinite and able to match the taste of each.

Каталог предоставляет информацию о палитре материалов, покрытий и дополнительных деталей, которые идеально подходят для создания множества различных комбинаций, щедро предоставляемых в Questo Texture Collection. Это эстетически богатое и разнообразное предложение, в котором Вы можете наслаждаться многообразием сочетаний и не думать, что эта комбинация является исчерпывающей, благодаря идее о взаимозаменяемости элементов. Благодаря 72 возможным комбинациям сочетаний покрытий и материалов выбор поистине представляется бесконечным и может удовлетворить самый взыскательный вкус.

Leggere l'atmosfera del bagno proposto

Reading the atmosphere of the suggested bathroom
Прочитайте атмосферу предлагаемой ванной комнаты

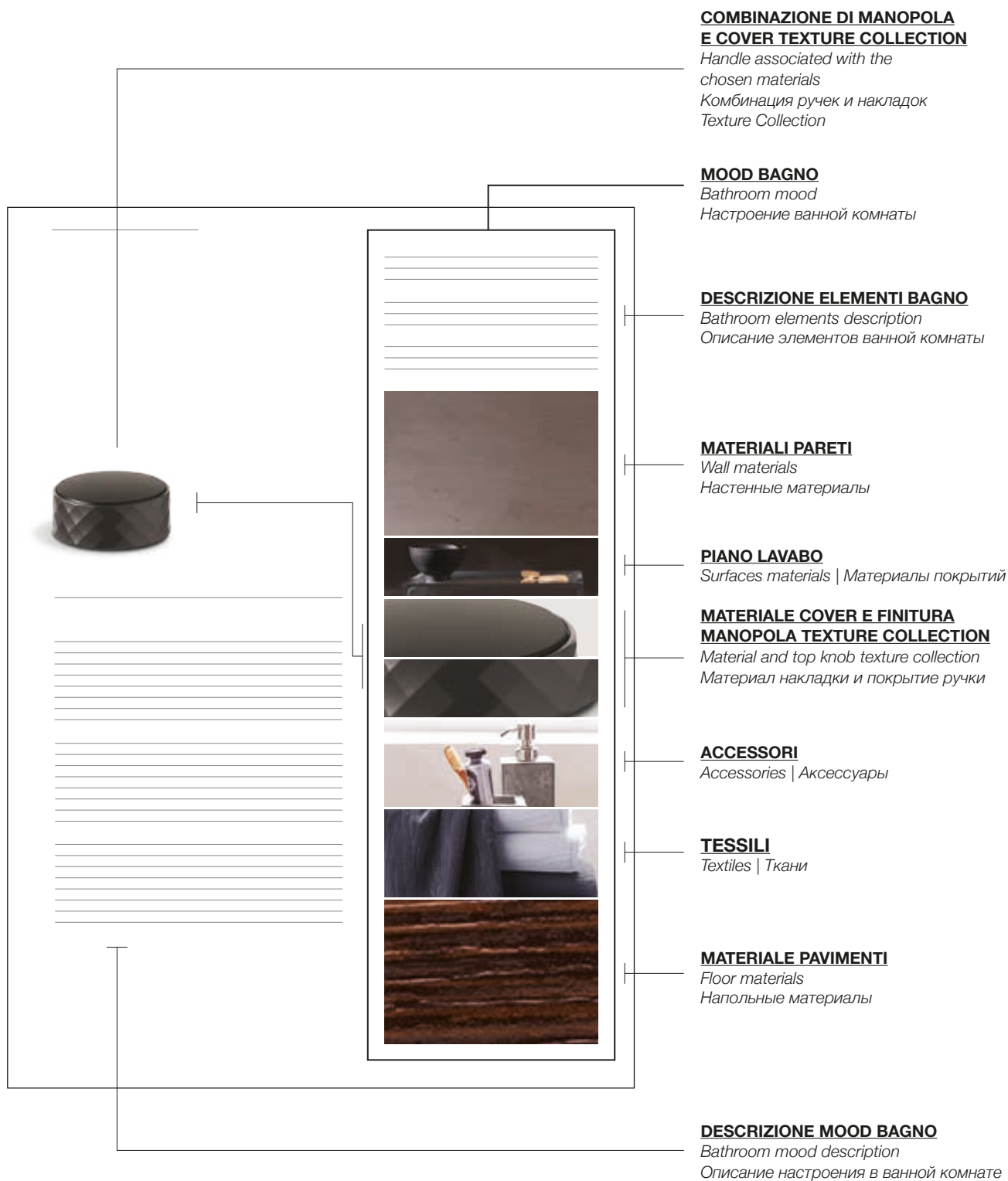

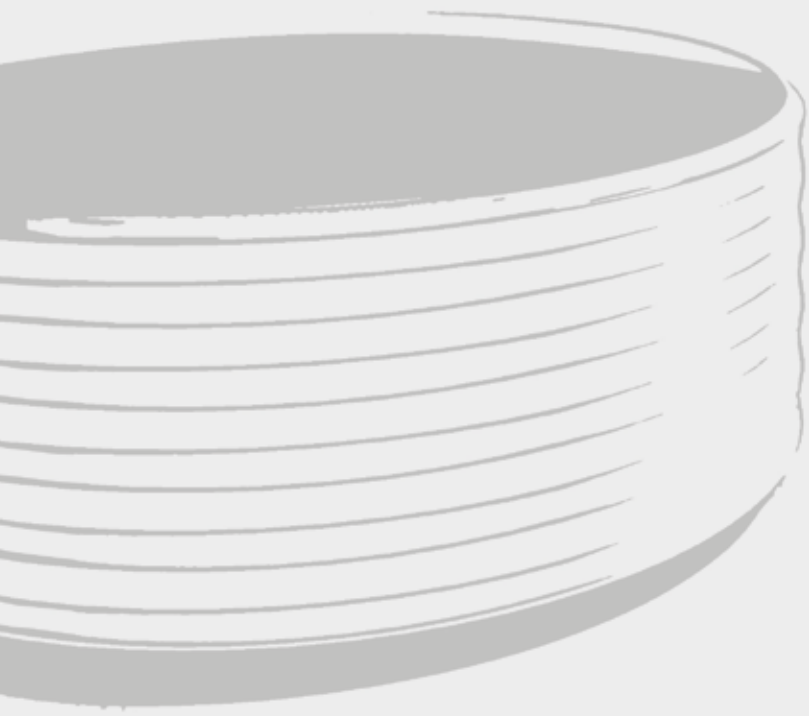

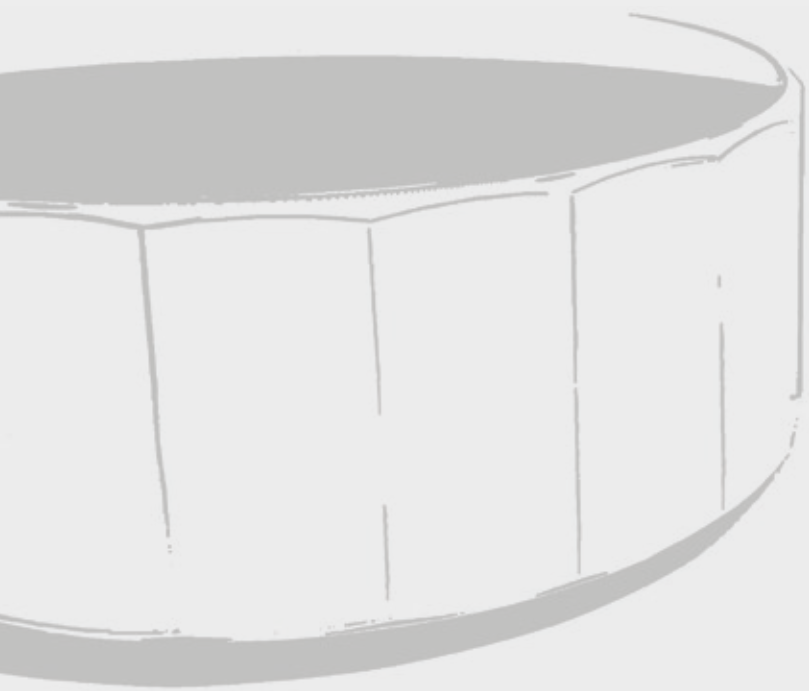



new york executive
taste of provence
marble purity
elegant contrast
scandinavian attitude
retro delights
industrial essentials
luxury extravagance

texture collection.

New York executive

**COMBINAZIONE TEXTURE COLLECTION
FINITURA NERA, TEXTURE CROSS, COVER NERO.**

L'ambiente è tipicamente maschile e rimanda a personalità forti e decise. I materiali scelti non lasciano spazio a incertezze; hanno linee energetiche e risolutive. Gli accessori sono essenziali e curati per legarsi perfettamente al resto. Il risultato è uno spazio carico di energia, accogliente e deciso, determinato a comunicare agli altri il proprio carattere.

*COMBINAZIONE TEXTURE COLLECTION
BLACK FINISH, CROSS TEXTURE, BLACK COVER.*

The environment is typically male and brings to mind a strong, decisive personality. The materials chosen do not leave space to uncertainties; they have energetic and resolute lines. Accessories are essential and cared for fit the rest perfectly. The result is a friendly space full of energy, determined to speak to others about its own character.

*КОМБИНАЦИЯ TEXTURE COLLECTION
ПОКРЫТИЕ ЧЁРНЫЙ, ГРАНЁННАЯ ТЕКСТУРА, НАКЛАДКА В ЧЁРНОМ.*

Типично мужская обстановка, обращённая к решительной и сильной личности. Выбор материалов не оставляет места для сомнений: это энергичные и решительные формы. Большое значение имеют аксессуары и связывают всё остальное воедино. Результат - пространство полное энергии, комфортное и решительное, определённо демонстрирует другим свой характер.

Mood:

Pareti in cemento, piani d'appoggio in sospensione, accessori in pietra grigia, tessuti in cotone nero e pavimento in wengé.

Mood:

Cement walls, suspended surfaces, grey stone accessories, black cotton textiles and wengé floor.

настроение:

Стены оштукатурены, подвесная столешница, аксессуары из серого камня, ткани из чёрного хлопка и полы венге.

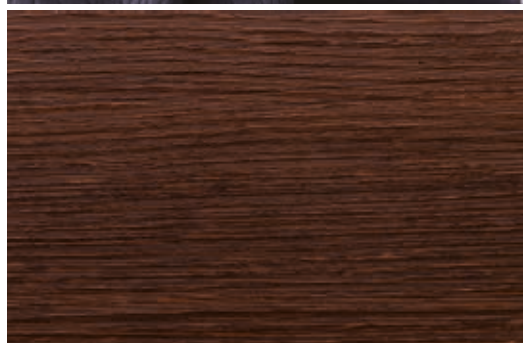
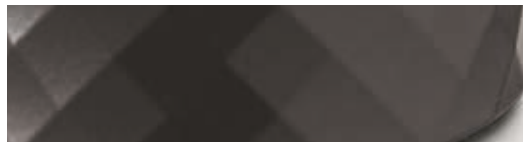
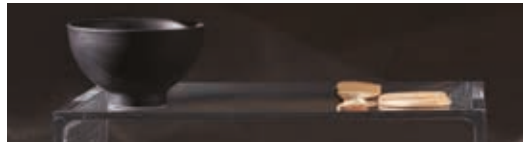



F5601/5XNS

Miscelatore lavabo a incasso

Wall mounted three-holes basin tap | Смеситель настенного монтажа на 3 отверстия

F6100/60XNS

Portasalviette cm. 60

Towel holder cm 60 | Полотенцедержатель 60 см



F6100/40XNS

Portasalvietta cm. 40

Towel holder cm 40 | Полотенцедержатель 40 см



F5604XNS

Gruppo esterno vasca con set doccia

Exposed bath tap with shower set

Смеситель для ванны внешнего монтажа с душевым комплектом

Taste of Provence

COMBINAZIONE TEXTURE COLLECTION

FINITURA BIANCA, TEXTURE VERTICAL, COVER BIANCO.

Le linee moderne e contemporanee di Texture Collection convivono perfettamente anche in un contesto caldo e accogliente dal sapore provenzale, tipico di una villa in campagna. Profumi, tessuti e luci riempiono l'ambiente di suggestioni sensoriali che trasformano la stanza da bagno in un ambiente da godere in tutta calma.

COMBINATION TEXTURE COLLECTION

WHITE FINISH, VERTICAL TEXTURE, WHITE COVER.

The modern and contemporary lines of Texture Collection coexist perfectly also in a warm and cozy Provencal flavor, typical of a country cottage. Perfumes, fabrics and lights fill the environment with sensory impressions. The soft colors and the simple shapes create a unique atmosphere turning the bathroom into an environment with enjoy in peace and quiet.

КОМБИНАЦИЯ TEXTURE COLLECTION

ПОКРЫТИЕ БЕЛЫЙ, ТЕКСТУРА ВЕРТИКАЛЬ, НАКЛАДКА В БЕЛОМ.

Современные линии Texture Collection идеально сочетаются также с тёплой и уютной обстановкой с провинциальным вкусом, типичной для загородной виллы. Ароматы, материалы, свет, наполняют обстановку чувственными ощущениями. Деликатные тона и простые формы создают единую атмосферу, которую сложно забыть. Ванна комната трансформируется в уголок наслаждения и расслабления, где Вы найдёте качество натуральных элементов и гармония деталей.

Mood:

Pareti in tappezzeria con geometrie lineari, piano in legno naturale, saponi profumati, accessori vintage e pavimento in legno grezzo.

Mood:

Wallpaper walls with geometric lines, natural wood surfaces, scented soaps, vintage accessories and raw wooden floor.

настроение:

На стенах обои с геометрией линий, столешница из натурального дерева, ароматические средства, аксессуары и пол из сырого дерева.

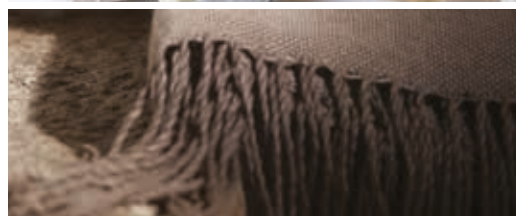
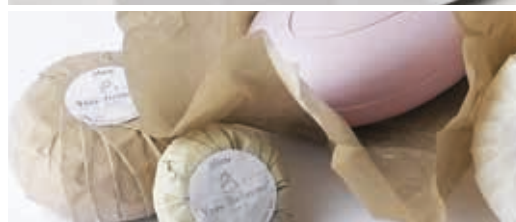
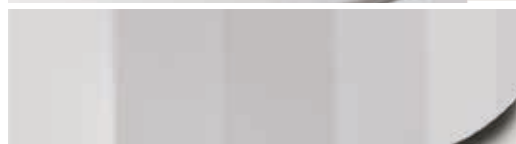
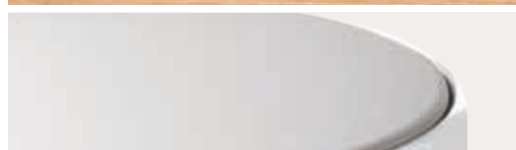
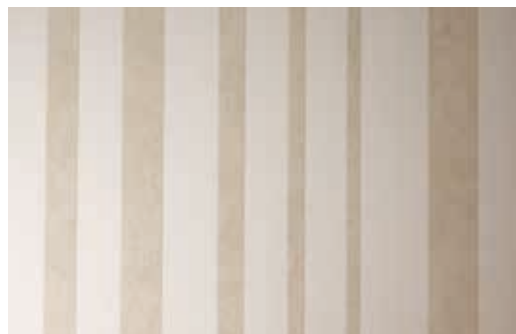



F5601VBS

Batteria lavabo

Three-holes basin tap

Смеситель на раковину на 3 отверстия



F5605/2VBS

Miscelatore doccia con colonna, soffione e doccia

Exposed shower mixer with shower column, showerhead and shower set

Смеситель для душа внешнего монтажа с душевой стойкой, верхним душем и душевым комплектом



F6104/1VBS

Gancio singolo

Single hook | Крючок одинарный

F6100/60VBS

Portasalviette cm. 60

Towel holder cm 60 | Полотенцедержатель 60 см



Marble purity

COMBINAZIONE TEXTURE COLLECTION

FINITURA CROMO, TEXTURE VERTICALE, COVER MARMO BIANCO.

Uno spazio completamente dedicato al relax e al benessere. I marmi bianchi, elementi centrali dell'ambiente, conferiscono alla stanza luminosità e preziosità. Si tratta di un lusso sofisticato e minimale, dove i toni freddi e chiari garantiscono quiete mentale e riposo anche alla vista. Gli accessori lavorati in ceramica bianca, così come fa la biancheria tessile, amplificano la sensazione di essere immersi in un ambiente essenziale e di qualità.

COMBINATION TEXTURE COLLECTION

CHROME FINISH, VERTICAL TEXTURE, WHITE MARBLE COVER.

An area entirely dedicated to relaxation and well being. The main feature, white marble, gives the room brightness and preciousness. A sophisticated, minimal luxury, where cold bright tones guarantee mental well being. The white ceramics accessories and linen, increase the feeling of being in a perfect place.

КОМБИНАЦИЯ TEXTURE COLLECTION

ПОКРЫТИЕ ХРОМ, ТЕКСТУРА ВЕРТИКАЛЬ, НАКЛАДКА БЕЛЫЙ МРАМОР.

Пространство, полностью посвящённое релаксу и наслаждению. Накладки из белого мрамора – центральный элемент обстановки, приносят в ванную комнату свет и в то же время роскошь. Речь идёт о изысканной роскоши минимализма, где холодные и светлые тона предоставляют душевное спокойствие и отдых для глаз. Аксессуары, созданные из белой керамики, кроме зрительного приносят также приятное тактильное ощущение, таким образом, детали усиливают впечатление от обстановки качества и роскоши.

Mood:

Pareti e piano in marmo di Carrara, accessori in ceramica bianca, tessuti bianchi e pavimenti in marmo di Carrara.

Mood:

Carrara marble walls and surfaces, white ceramic accessories, white textiles and Carrara marble floor.

настроение:

Стены и столешница из мрамора Каррара, аксессуары из белой керамики, белые ткани, пол из мрамора Каррара

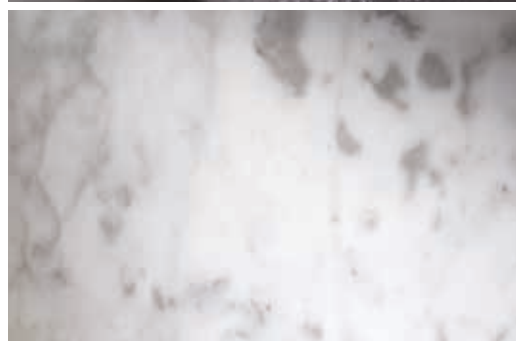
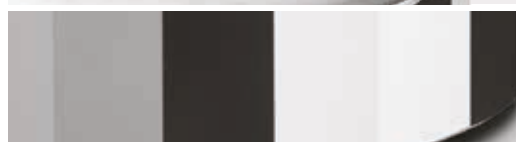
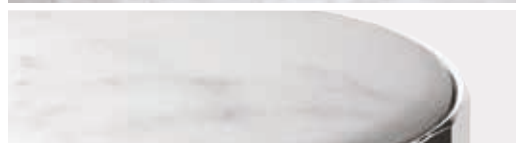



F5621VCR

Monoforo lavabo

Single-hole basin tap | Смеситель на раковину на 1 отверстие



F6104/1VCR

Gancio singolo

Single hook | Крючок одинарный



F5614VCR

Miscelatore bordo vasca

Deck mounted bath mixer | Смеситель к борту ванны



Elegant contrast

COMBINAZIONE TEXTURE COLLECTION
FINITURA NERA, TEXTURE VERTICAL, COVER BIANCO.

Un ambiente dalla forte impronta decorativa, i cui netti contrasti sono sottolineati da linee decise e decori che richiamano la tradizione. Uno stile classico e al contempo moderno, dove materiali preziosi e tessuti di qualità si abbinano ad accessori ed essenze pregiate.

COMBINAZIONE TEXTURE COLLECTION
BLACK FINISH, VERTICAL TEXTURE, WHITE COVER.

An environment with a strong decorative character, whose sharp contrasts are underlined by strong lines and patterns that recall tradition. A classic, yet modern style, where precious materials and quality fabrics combine with accessories and precious essences.

КОМБИНАЦИЯ TEXTURE COLLECTION
ПОКРЫТИЕ БЕЛЫЙ, ТЕКСТУРА ВЕРТИКАЛЬ, НАКЛАДКА ХРОМ.

Обстановка с уникальным отпечатком декора, в которой контрасты подчёркивают чёткие линии и декоры которые призывают к традициям. Классический и в то же время современный стиль, где изысканные материалы и качественные отделки сочетаются в благородное единство.

Mood:

Pareti in ceramica a listoni bianchi e neri, piano in rovere nero, accessori in ceramica, tessuti in cotone, pavimento con mattonelle miste in ceramica bianche e nere.

Mood:

Ceramic walls with black and white tiles, black Oakwood surfaces, ceramic accessories, cotton textiles and black and white ceramic floor.

настроение:

Стены облицованы керамикой в сочетании белого и чёрного, столешница из тёмного дуба, аксессуары из керамики, ткани из хлопка, с элементами белого и чёрного.

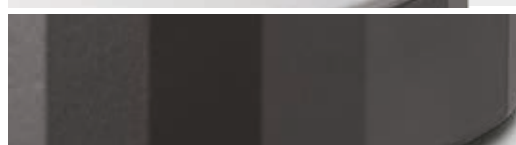
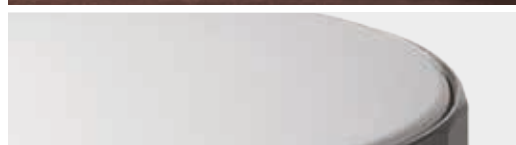
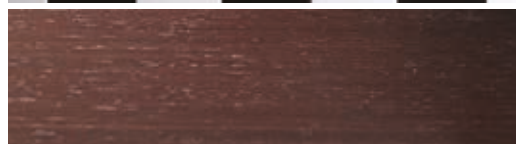



F5611VNS

Batteria lavabo con canna girevole

Three-holes basin tap with swivel spout

Смеситель на раковину на 3 отверстия с вращающимся изливом

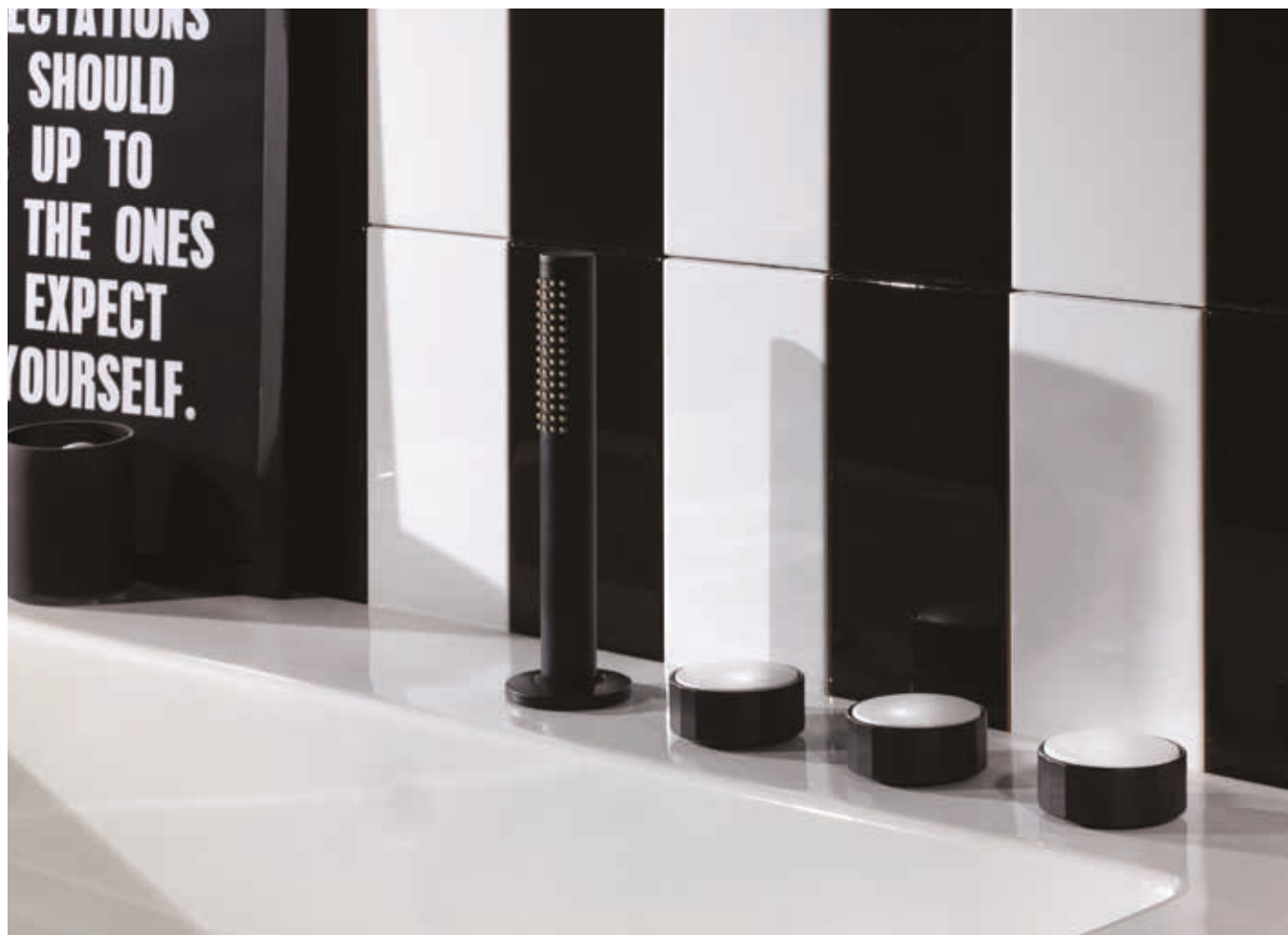

F5614/1VNS

Miscelatore bordo vasca

Deck mounted bath mixer | Смеситель к борту ванны



F5603X2VNS

Miscelatore termostatico da incasso

Built-in thermostatic mixer | Встроенный термостатический смеситель



F5601/5HCR

Miscelatore lavabo da incasso

Wall mounted three-holes basin tap | Встраиваемый смеситель для раковины



F5609X6HCR

Miscelatore a incasso con deviatore a 3 uscite

Built-in mixer with 3 outlets diverter

Встроенный смеситель с переключателем на 3 источника



F5621HCR

Monoforo lavabo

Single-hole basin tap | Смеситель на раковину на 1 отверстие

F6100/40HCR

Portasalviette cm. 40

Towel holder cm 40 | Полотенцедержатель 40 см

Retro delights

COMBINAZIONE TEXTURE COLLECTION

FINITURA ORO, TEXTURE HORIZONTAL, COVER ORO.

Elementi moderni si uniscono a componenti dal sapore retrò, creando uno spazio nostalgico ma attuale, una commistione di tempi e gusti distinti. Le linee inconfondibili del pattern Decò si uniscono a quelle degli accessori contemporanei rendendo l'ambiente uno spazio inatteso, in bilico tra vecchio e nuovo. L'oro, la cromia dominante, accostandosi a colori più tenui, non sovraccarica lo spazio ma ne impreziosisce tutte le singole componenti.

COMBINATION TEXTURE COLLECTION

GOLD FINISH, HORIZONTAL TEXTURE, GOLD COVER.

Modern elements are combined with retro components, creating a nostalgic but also modern space, a mixture of different times and taste. The distinctive lines of the Deco pattern join those of the contemporary accessories, making the environment an unexpected space, in balance between old and new. Gold is the dominant color, that combined with softer colors, does not overload the space but embellishes each component.

КОМБИНАЦИЯ TEXTURE COLLECTION

ПОКРЫТИЕ ЗОЛОТО, ТЕКСТУРА ГОРИЗОНТАЛЬ, НАКЛАДКА В ЗОЛОТЕ.

Современные элементы неожиданно объединяются в детали с налётом ретро, создавая пространство ностальгии в настоящем времени. Это смешение эпох и различных вкусов, которые создают новый, персональный эквилибриум. Характерные линии в стиле Decò объединяются с современными аксессуарами, принося в обстановку элемент неожиданности, равновесие между старым и новым. Золото и хром доминируют, но имеют значение лёгких тонов, не перегружающих обстановку, но обогащающих каждый её отдельный компонент. Результатом является непривычная и в то же время последовательная в каждой своей детали атмосфера.

Mood:

Pareti con carta da parati con pattern oro, piano in okite color avorio, accessori dorati, tessuti color sabbia e pavimentazione in travertino dorato.

Mood:

Golden patterned wallpaper walls, ivory okite surfaces, gold plated accessories, sand colour textiles and golden travertine floor.

НАСТРОЕНИЕ:

На стенах обои с вставками из золота, столешница из оките (итальянский кварц), оттенок слоновая кость, позолоченные аксессуары, ткани в цвете песка и полы из мрамора травертино позолоченного.

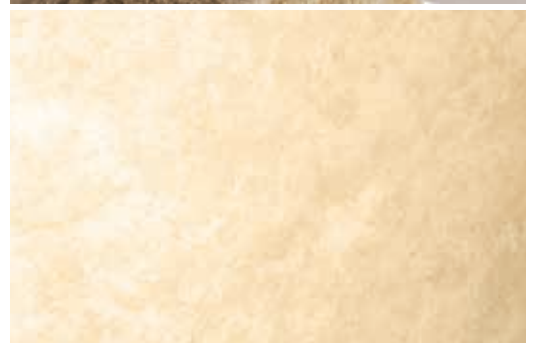



F5601HOR

Batteria lavabo

Three-holes basin tap

Смеситель на раковину на 3 отверстия



F5614HOR

Miscelatore bordo vasca

Deck mounted bath mixer | Смеситель к борту ванны



F5603X4HOR

Miscelatore termostatico da incasso

Built-in thermostatic mixer | Встроенный термостатический смеситель



F5601/5XCR

Miscelatore lavabo da incasso

Wall mounted three-holes basin tap | Смеситель для раковины настенного монтажа



F5602XCR

Monoforo bidet

Single-hole bidet tap | Смеситель для биде на 1 отверстие

F6105/1XCR

Portarotolo

Toilet roll holder | Держатель для туалетной бумаги



F5609X2XCR

Miscelatore incasso con deviatore a 2 uscite

Built-in mixer with 2 outlets diverter

Встроенный смеситель с переключателем на 2 источника



Luxury extravagance

COMBINAZIONE TEXTURE COLLECTION
FINITURA ORO, TEXTURE CROSS, COVER MARMO NERO.

Ori e marmi connotano un luogo fatto di ricchezze e suggestioni difficili da trovare. Le pareti in marmo portoro sono un chiaro segno di un gusto personale deciso e al tempo stesso esuberante, che ha fatto dei materiali impiegati una dichiarazione di status e carattere. Gli elementi scelti per arredare l'ambiente vanno dall'oro al marmo nero e riscaldano l'atmosfera già di per sé suggestiva, arricchendola di materiali preziosi e di qualità.

COMBINATION TEXTURE COLLECTION
GOLD FINISH, CROSS TEXTURE, BLACK MARBLE COVER.

Gold and marble evoke a sense of wealth and charm hard to find elsewhere. The Portoro marble walls are a clear sign of a personal, strong and at the same time exuberant taste, that made a statement of the materials used in status and character. The items chosen to decorate the environment, ranging from gold to black marble, warm up the already impressive atmosphere, enriching it with precious and quality materials.

КОМБИНАЦИЯ TEXTURE COLLECTION
ПОКРЫТИЕ ЗОЛОТО, ОГРАНЕННАЯ ТЕКСТУРА, НАКЛАДКА В ЧЁРНОМ МРАМОРЕ.

Золото и мрамор всегда являются отличительной чертой обстановки, выполненной с богатством и очарованием, которое сложно найти, где либо ещё. Стены в мраморе порторо – это явный знак персонального вкуса, решительного, но в то же время живого, который приводит изысканные материалы к демонстрации статуса и характера. Богатство и жизненность цветов придают атмосфере твёрдую персональность. Выбранные для создания дизайна ванной комнаты элементы из золота и чёрного мрамора подогревают атмосферу, обогащая её благородными и качественными материалами.

Mood:

Pareti in marmo portoro, piano in marmo nero, accessori neri e oro, tessuti in lino e seta e pavimento in marmo dorato.

Mood:

Portoro marble walls, black marble surfaces, golden and black accessories, linen and silk textiles and golden marble floor.

настроение:

Стены в мраморе порторо, столешница в чёрном мраморе, позолоченные аксессуары, ткани из чёрного льна и шёлка, полы из мрамора травертино позолоченного.

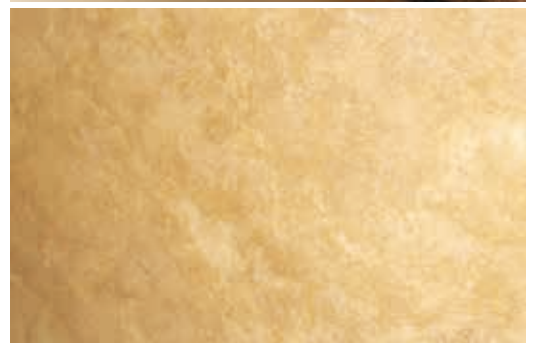
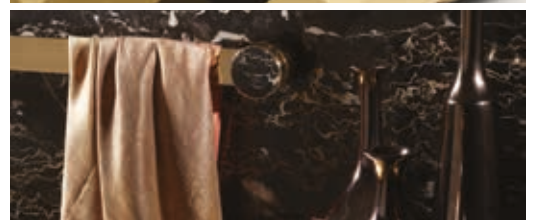



F5611XOR

Batteria lavabo con canna girevole

Three-holes basin tap with swivel spout

Смеситель на раковину на 3 отверстия с вращающимся изливом



F5605XOR

Miscelatore doccia con set doccia

Exposed bath tap with shower set

Смеситель для ванны внешнего монтажа с душевым комплектом



F6100/40XOR

Portasalviette cm. 40

Towel holder cm 40 | Полотенцедержатель 40 см

Texture Collection: come funziona

Texture Collection: how it works | Texture Collection: как функционирует

Texture Collection è un sistema semplice composto da due parti, manopola e cover, facilmente assemblabili tra loro, in grado di dare vita a un prodotto flessibile capace di incontrare i gusti di ognuno e seguire mode e tendenze sempre attuali. Attraverso le numerose combinazioni disponibili si potrà, infatti, ottenere sempre un prodotto finale che soddisfi le proprie esigenze e che sia facilmente personalizzabile.

Texture collection is a simple system composed of two parts: handle and cover that can be easily put together to create a flexible product to suit all tastes while following trends and styles.

With the numerous combinations available you can always come up with a final product you want.

Texture Collection - это простая система, состоящая из двух частей – ручки и накладки, легко устанавливаемыми между собой, способными вдохнуть жизнь в любой продукт, и удовлетворить любой вкус, следовать всегда модным и актуальным тенденциям. Благодаря многочисленным возможным комбинациям в этой коллекции каждый может получить действительно индивидуальное решение, соответствующее своим предпочтениям, которое будет радовать взгляд при нахождении в ванной комнате.

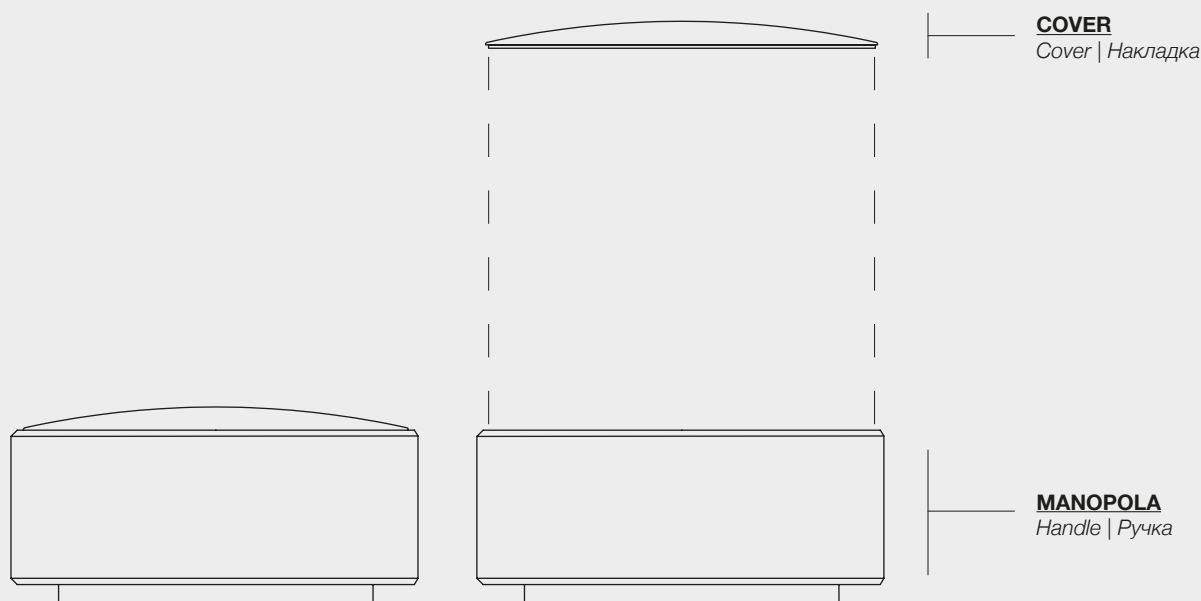

Cover / Materiali

Cover / Materials | Накладка / Материалы



Cromo
Chrome | Хром



Bianco opaco
White Matt | Белый матовый



Nero Opaco
Black Matt | Чёрный матовый



Marmo Bianco Carrara
White Carrara Marble
Белый Мрамор Carrara



Marmo Nero Portoro
Black Portoro Marble
Чёрный Мрамор Portoro



Oro
Gold | Золото

Manopola / Texture

Handle / Texture | Ручка / Текстура

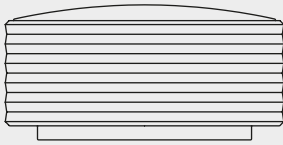

H
Horizontal Texture

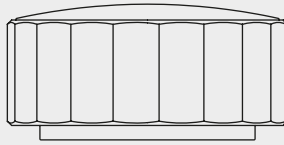

V
Vertical Texture

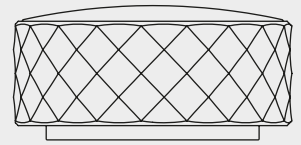

X
Cross Texture

Manopola / Finiture

Handle / Finishes | Ручка / Покрытия

CR
Cromo
Chrome | Хром

BS
Bianco Opaco
White Matt | Белый матовый

NS
Nero Opaco
Black Matt | Чёрный матовый

OR
Oro
Gold | Золото

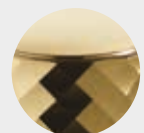
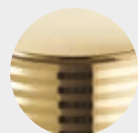
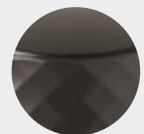
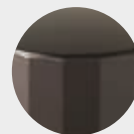
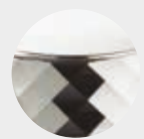

Finitura Cromo

Chrome finish | Покрытие Хром

H



V



X



Finitura Bianca

White finish | Покрытие Белый

H



V



X



Finitura Nera

Black finish | Покрытие Чёрный

H

V

X

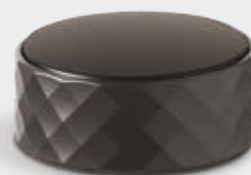

Finitura Oro

Gold finish | Покрытие Золото

H



V



X



Credits

companies

ALPI SPA
ALTAECO
ARSALITARTES
ARTCERAM
CERAMICHE CALCATERRA
FLAMINIA
GLASS DESIGN
Gianni Vigone (GVA GROUP)
SCARABEO
SELVA VETRI
TESTORI
VECCHI LIBRIECOSE

graphic project

OFFICEMILANO

photo

WALTER ZERLA

visual designer

DAVIDE VERCELLI

fima | CARLO FRATTINI®
PUBBLICITÀ

© Fima Carlo Frattini S.p.A.
tutti i diritti riservati / All rights reserved

printed in Italy 06-2015

TEXTURE COLLECTION F8055



8 013749 382827

Fima Carlo Frattini S.p.A.
28010 - Briga Novarese (NO)
Via Borgomanero, 105
tel. +39 0322 9549 (r.a.)
fax. +39 0322 956149
e-mail: info@fimacf.com
www.fimacf.com

fima | CARLO FRATTINI®
r u b i n e t t e r i e

WELLNESS 
EXPERIENCE

#WELLNESS



#WELLNESS

#INDICE

INDEX

#COMPANY	06
#NU	11
#CLOUD	21
#SFERA	31
#HARMONIA	41
#MODULAR	51
#SHOWERHEAD	61
#SQUARE&ROUND	71
#FIMABOXES	79

DIMENSIONE TOTALE
TOTAL SIZE

CODICE E GETTI
CODE AND SPRAY

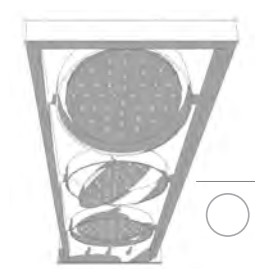
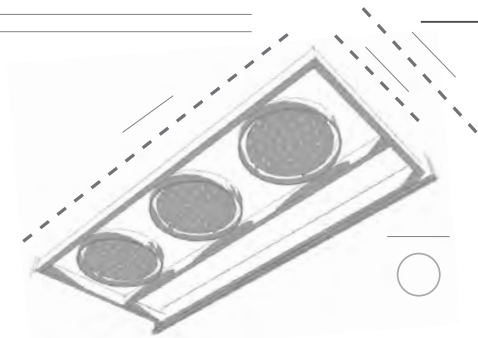

SPECIFICHE TECNICHE
TECHNICAL SPECIFICATIONS

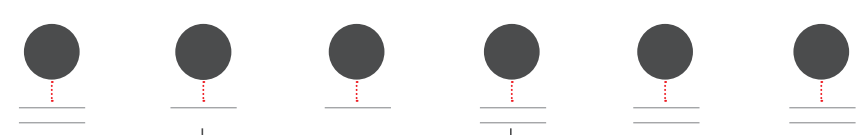

MATERIALI
MATERIALS

DIMENSIONI GETTI
JETS DIMENSIONS

INSTALLAZIONI
INSTALLATIONS

PORTATA CONSIGLIATA A 3BAR
SUGGESTED FLOW RATE 3BAR

FUNZIONI/GETTI
FUNCTIONS/JETS

FINITURE
FINISHING

SCOPRI IL TUO WELLNESS

DISCOVER YOUR WELLNESS

ESEMPIO DI COMPOSIZIONE DOCCIA
EXAMPLE SHOWER COMPOSITION

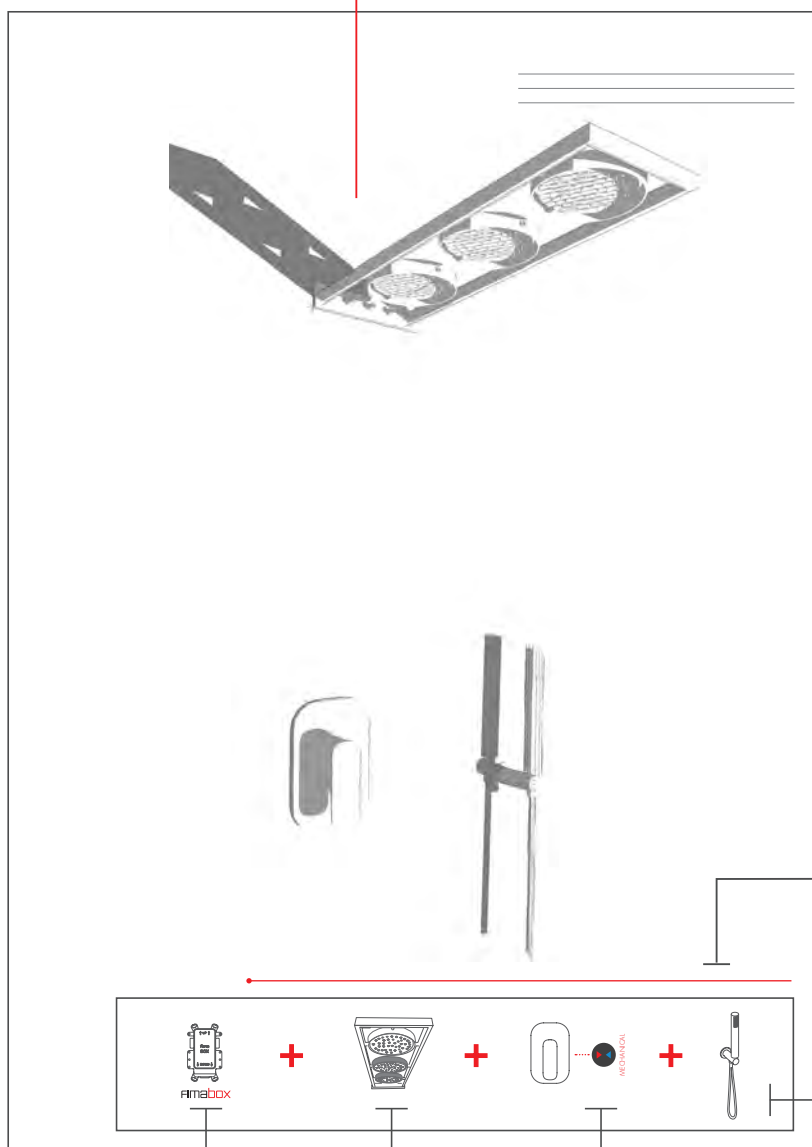

ELEMENTI DELLA COMPOSIZIONE
ELEMENTS OF COMPOSITION

ALTRI ELEMENTI PER
PERSONALIZZARE IL TUO
SPAZIO DOCCIA
OTHER ITEMS TO CUSTOMISE
YOUR SHOWER

INSTALLA IL SOFFIONE
CHE PREFERISCI
INSTALL YOUR FAVOURITE
SHOWERHEAD

SCOPRI TUTTI I CORPI INCASSO
FIMABOXES A PAG. 79
FIND OUT ALL FIMABOXES BUILT-IN
BOXES LOOKING AT PAG. 79

SCEGLI LA PARTE ESTERNA
ADATTA AL TUO STILE
CHOOSE THE EXTERNAL PART
MOST SUITED TO YOUR STYLE

#COMPANY

Tecnologia, estetica ed elevate prestazioni: FIMA Carlo Frattini propone da oltre 50 anni rubinetteria di altissima qualità destinata a durare nel tempo e capace di dare valore aggiunto ad ogni progetto. L'Azienda ha assunto negli anni un taglio innovativo ed in continua evoluzione, grazie alla creatività, al design e alle nuove tecnologie, che differenziano le sue collezioni. FIMA, infatti, si rinnova costantemente, come dimostrano l'alto livello progettuale e qualitativo della produzione, i continui investimenti in ricerca, la forte espansione nazionale e internazionale, la professionalità del team aziendale. Questo atteggiamento ha portato l'Azienda ad interpretare e anticipare le esigenze contemporanee e future del mercato, proponendo prodotti all'avanguardia per design e tecnologia, curati singolarmente in ogni dettaglio.

Technology, aesthetics and performance: FIMA Carlo Frattini has been offering for more than 50 years high quality faucets designed to last over time and able to give added value to each project. Over these years the Company has taken an innovative and evolving feature, thanks to its creativity, design and new technologies, which differentiate its collections from others. FIMA, in fact, is being continually upgraded by way of its high level of designs, quality of production, continuous investment in research, the strong national and international expansion and the professionalism of the corporate team. This attitude has led the company to understand and anticipate the contemporary and future market needs by offering technically and esthetically advanced products, which are treated individually in every detail.

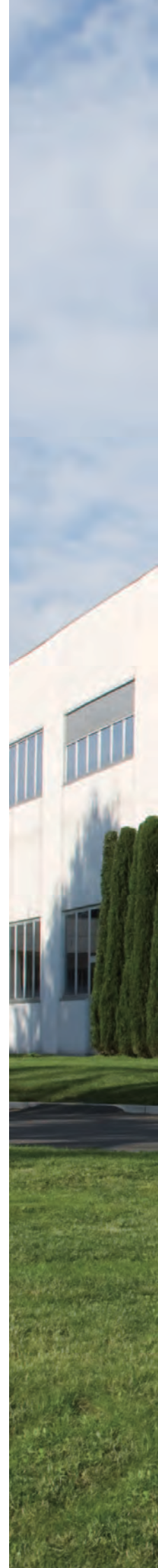

fima | CARLO FRATTINI[®]
INDUSTRIE



#GREEN

FIMA CARLO FRATTINI da anni evolve i propri processi produttivi finalizzandoli ad una costante riduzione di risorse, materiali ed energia ed operando un controllo costante sulle materie prime, sui consumi e sull'impatto ambientale di tutte le fasi di produzione e commercializzazione dei propri prodotti.

Un'azienda eco sostenibile, alimentata da energia auto-prodotta e in grado di realizzare prodotti sicuri per la salute e per l'ambiente con un basso impatto ambientale.

FIMA CARLO FRATTINI for many years has been constantly developing its production processes in order to reduce the use of resources, materials and energy. Furthermore all FIMA Carlo Frattini projects are developed considering all the steps of a product's life, from its manufacturing to the shipment till its dismantlement.

An environmentally friendly company, powered by self-produced electricity and able to produce products safe for human health and the environment with a very low environmental impact.

#QUALITY

I migliori materiali e tecnologie all'avanguardia per garantire un utilizzo quotidiano impassibile al trascorrere del tempo. Fima Carlo Frattini sposa un approccio globale alla qualità che deriva da un'attenzione all'innovazione tecnologica, adottando processi industriali all'avanguardia, scegliendo le migliori materie prime. Tutti i prodotti vengono sottoposti a minuziosi e severi controlli in ogni fase di lavorazione e sono progettati in modo da rispettare tutte le più rigide normative internazionali. Ulteriore testimonianza di questa filosofia improntata alla qualità totale è la garanzia che si estende per ben 7 anni su tutta la produzione.

Best materials and cutting-edge technologies as a guarantee for an everyday use unchanging over time. FIMA Carlo Frattini follows a global approach to quality coming from a particular attention to technology innovation, by adopting cutting-edge industrial processes, choosing the best raw materials. Detailed strict controls are carried out on all the products in every production phase and all the items are designed in order to respect the most stringent international regulations. Its seven-year extended warranty on all the product is a further evidence of this philosophy based on total quality.

#DESIGN

Prodotti unici nel loro genere, studiati per massimizzare il comfort di utilizzo e con un inconfondibile tocco Made in Italy. Convinta del potere della creatività, del design e delle nuove tecnologie, l'Azienda ha assunto negli anni un taglio innovativo e in continua evoluzione. Questo atteggiamento l'ha portata a interpretare e anticipare le esigenze presenti e future del mercato, proponendo prodotti all'avanguardia per design e tecnologia. Studiati per massimizzare il comfort di utilizzo e caratterizzati da uno stile unico sono progettati da nomi noti del design.

One-of-a-kind products, designed to maximize the comfort in use with an unmistakable hint of Made in Italy. The Company, firmly confident of the power of creativity, design, and new technologies, has developed over the years innovative and ever-changing traits. This approach has led it to interpret and anticipate the current and future market needs, by proposing state-of-the-art products in terms of design and technology. Designed to maximize the comfort in use and characterised by a unique style, all the items are designed by well-known designers.

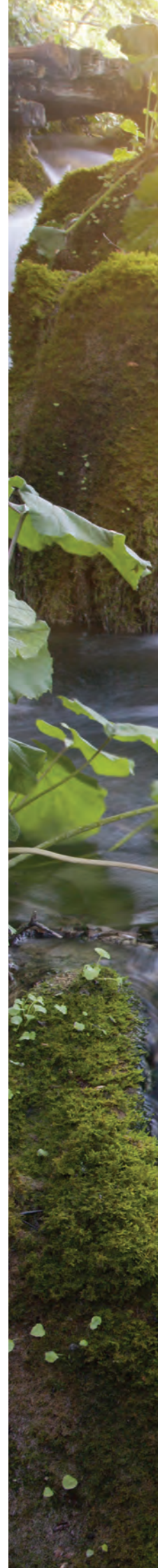



#NU

AWARDWINNER2017
DESIGN PLUS

DAVIDE VERCELLI design

NU

#DESIGN











L'ORIENTAMENTO FLUIDO
DEI SOFFIONI ACCAREZZA
IL TUO CORPO

THE FLUID ORIENTATION OF THE
SHOWERHEADS CARESSES YOUR BODY

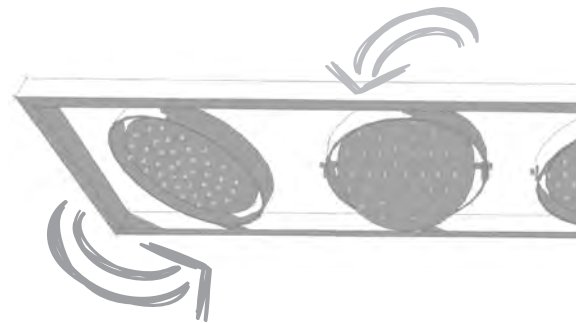
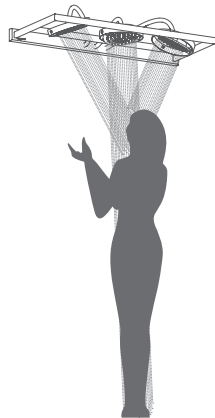

3 DIVERSE INSTALLAZIONI

DIFFERENT INSTALLATIONS

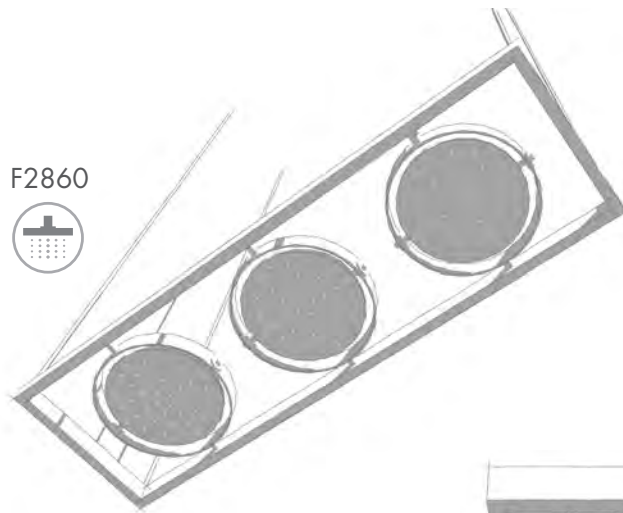
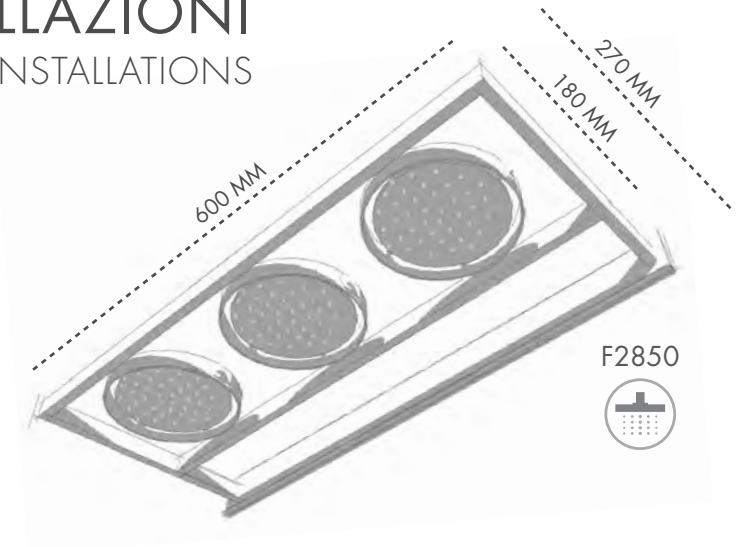

SPECIFICHE TECNICHE • TECHNICAL SPECIFICATIONS



ACCIAIO INOX
STAINLESS STEEL



20 L/MIN.



Ø 120 MM



GETTO A PIOGGIA
RAIN FLOW



PARETE • SOFFITTO • SOSPESO
WALL • CEILING • SUSPENDED



CROMO
CHROME



COMPOSIZIONE 1

COMPOSITIONS

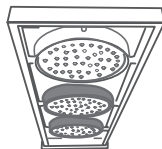
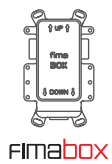
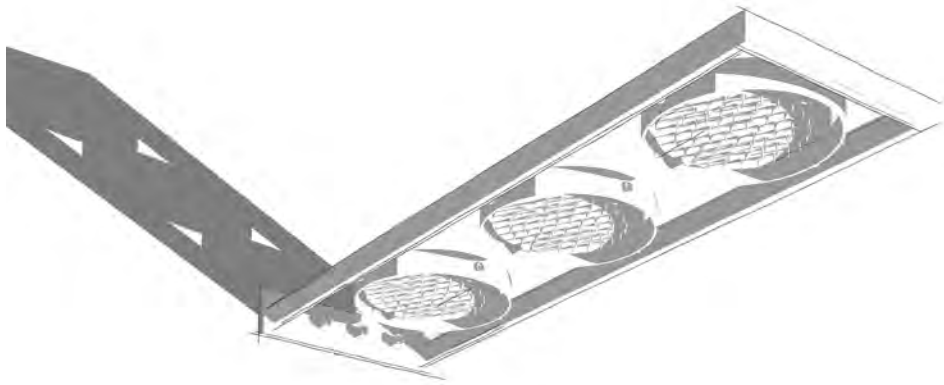

#CLOUD



AWARDWINNER2015
DESIGN PLUS

CLOUD

#GREEN









ACQUA E LUCE FONTI DI ENERGIA E BENESSERE

WATER AND LIGHT: SOURCE OF
ENERGY AND WELLNESS

F2650



F2650C•B•N

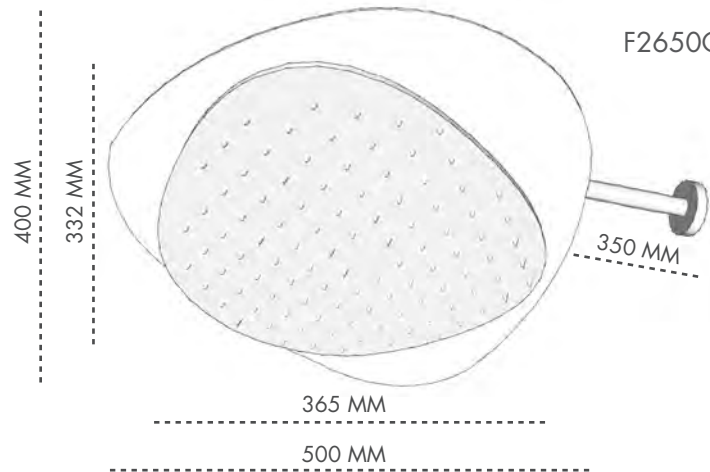

F2652
(300 mm braccio a soffitto - ceiling bracket)

F2653
(150 mm braccio a soffitto - ceiling bracket)



F2652C•B•N
(300 mm braccio a soffitto - ceiling bracket)

F2653C•B•N
(150 mm braccio a soffitto - ceiling bracket)



F2651



F2651C•B•N

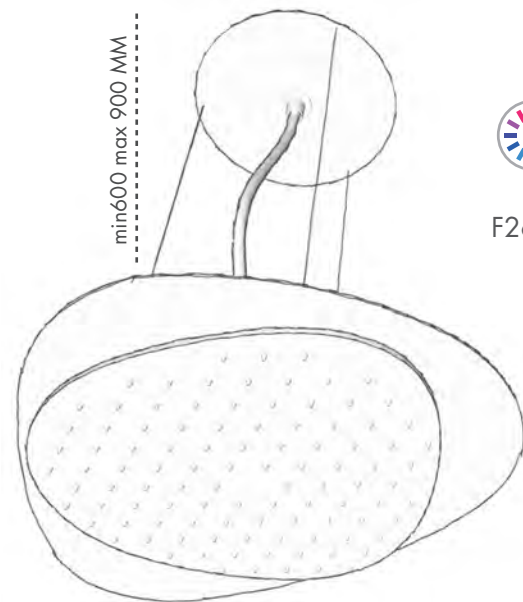

SPECIFICHE TECNICHE • TECHNICAL SPECIFICATIONS



ACCIAIO INOX
STAINLESS STEEL



15 L/MIN.



365x330 MM



GETTO A PIOGGIA
RAIN FLOW



PARETE•SOFFITTO•SOSPESO
WALL•CEILING•SUSPENDED



CROMO•BIANCO•NERO
CHROME•WHITE•BLACK
(PIASTRA SUP - UPPER PLAT)





CR • CROMO CHROME



BS • BIANCO WHITE



NS • NERO BLACK

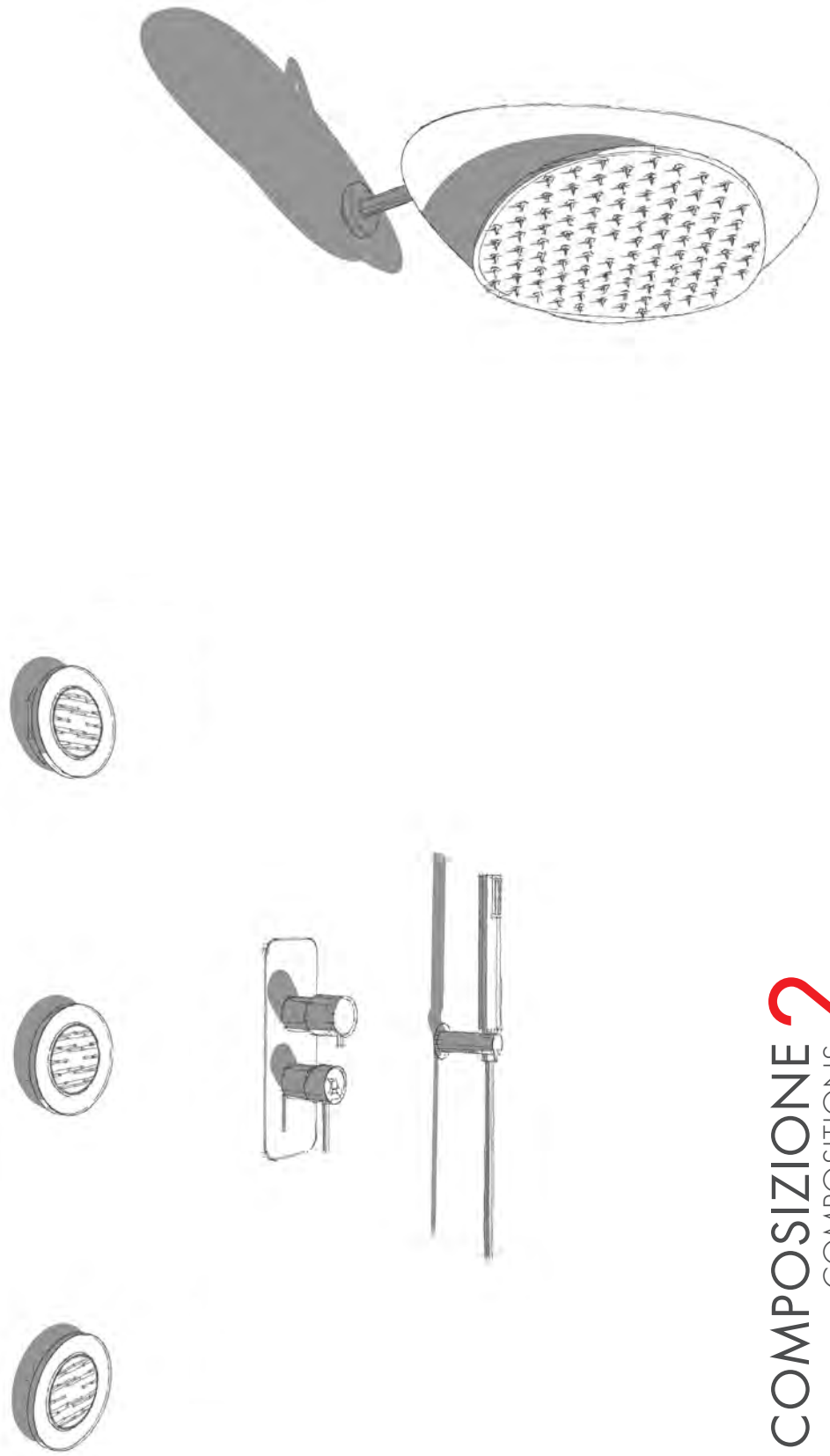

COMPOSIZIONE 2

COMPOSITIONS

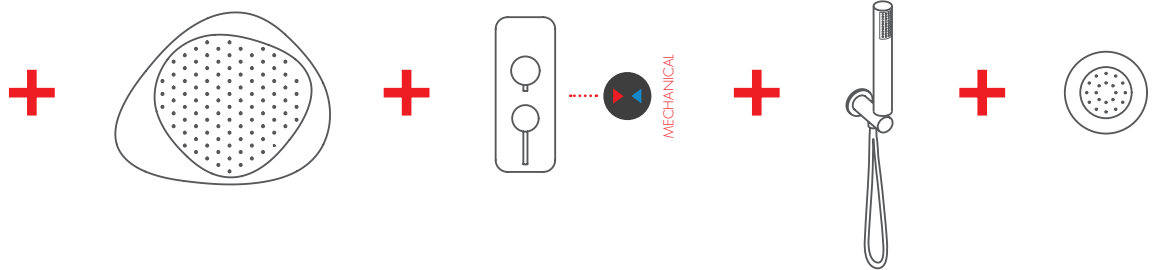
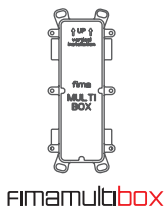

MECHANICAL

#SFERA

AWARDWINNER2010
DESIGN **PLUS**

MENEGHELLO PAOLELLI ASSOCIATI design

SFERA

#EMOTIONS











3 FINITURE FINISHINGS



CR • CROMO CHROME



BS • BIANCO WHITE



NS • NERO BLACK

2 POSSIBILITÀ DI INSTALLAZIONE CHOICES FOR THE INSTALLATION

F2340/1
soffitto - ceiling

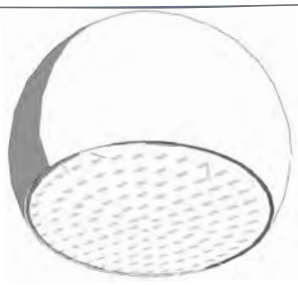

Ø 200 MM



F2340
parete - wall

SPECIFICHE TECNICHE • TECHNICAL SPECIFICATIONS



OTTONE
BRASS



15 L.MIN.



Ø 200 MM



GETTO A PIOGGIA
RAIN FLOW



PARETE • SOFFITTO
WALL • CEILING



CROMO • BIANCO • NERO
CHROME • WHITE • BLACK



COMPOSIZIONE 3

COMPOSITIONS

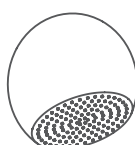
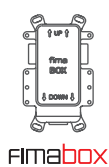
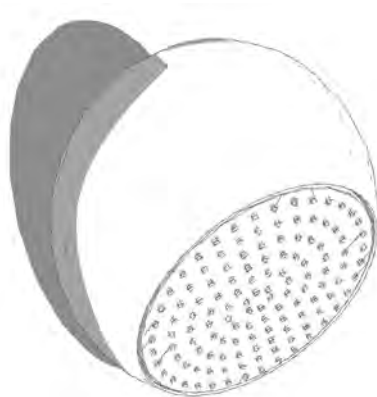
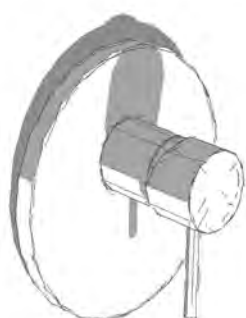

MECHANICAL

#HARMONIA





ARMONIA

#TECHNOLOGY







SPECIFICHE TECNICHE • TECHNICAL SPECIFICATIONS



ACCIAIO INOX
STAINLESS STEEL



15 L./MIN.
30 L./MIN.
FOR 950x950



500x500 MM
700x400 MM
950x950 MM



PIOGGIA • CASCATA • NEBULIZZATO
RAIN • WATERFALL • MIST SPRAY



SOFFITTO
CEILING



CROMO
CHROME

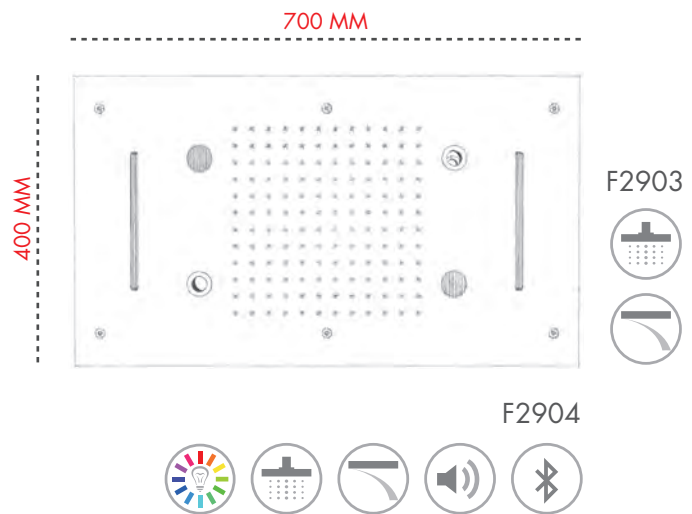
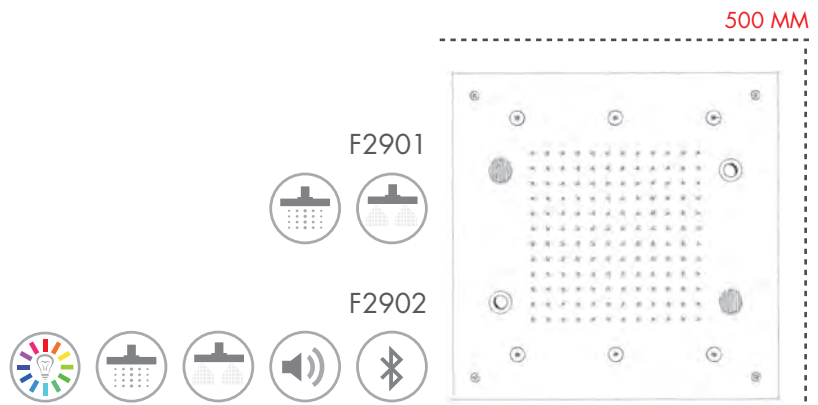
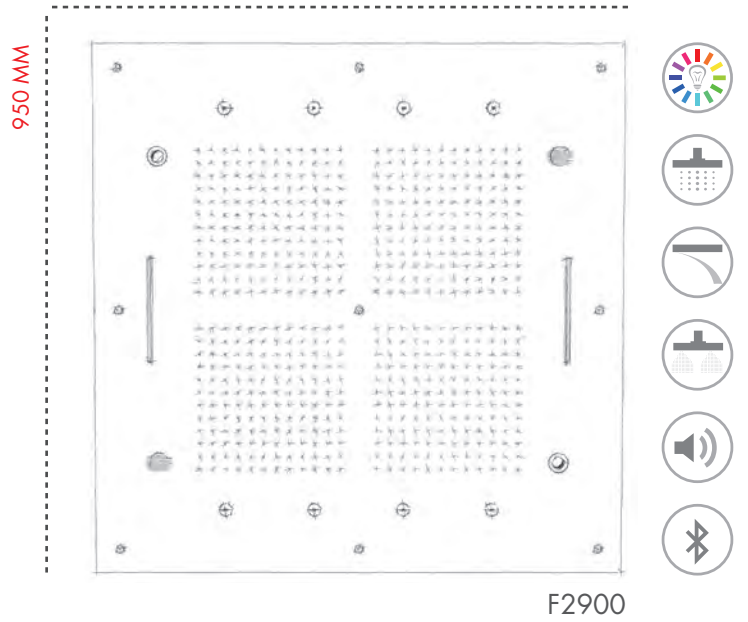

GIOCHI D'ACQUA,
 LUCE E MUSICA
 IN GRADO DI
 GENERARE EMOZIONI

PLAY OF WATER, LIGHT AND MUSIC
 SOURCE OF EMOTIONS



COMPOSIZIONE 4

COMPOSITIONS

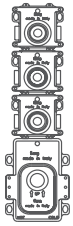
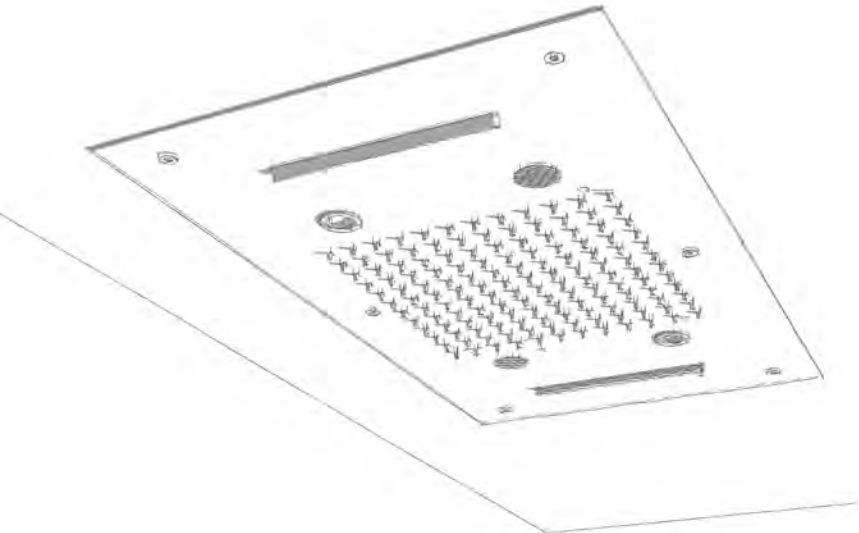

FIMathermbox

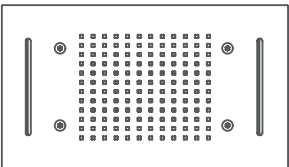

38

THERMOSTATIC

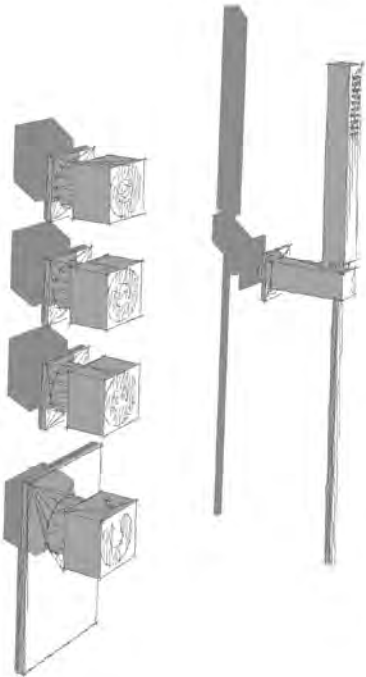

#MODULAR



ULAR

T









5 MODULI DIFFERENTI DIFFERENTS MODULES

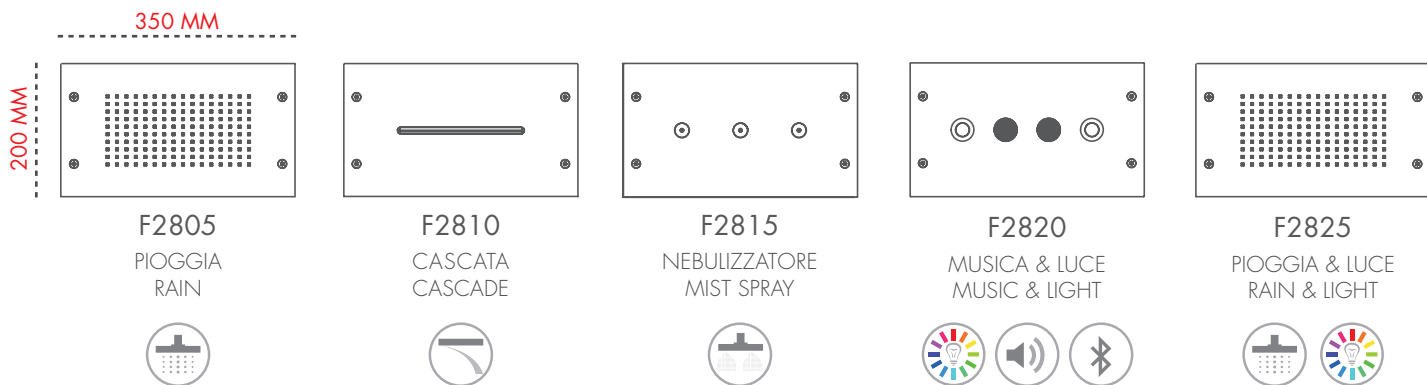

COMPONI I TUOI SOFFIONI DOCCIA COMPOSE YOUR SHOWERHEADS

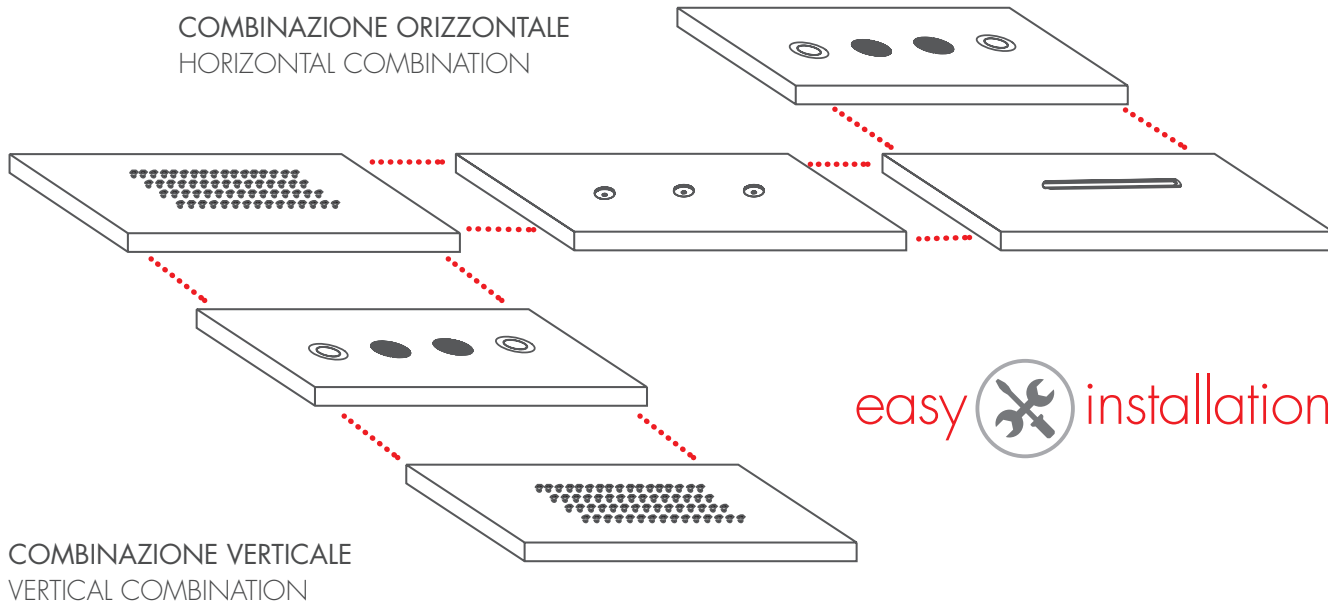

e • and...

PERSONALIZZA
LA TUA INSTALLAZIONE
CHOOSE YOUR PERSONAL INSTALLATION



SPECIFICHE TECNICHE • TECHNICAL SPECIFICATIONS



ACCIAIO INOX
STAINLESS STEEL



15 L·MIN.
RAIN
6 L·MIN.
WATERFALL•MIST SPRAY



350x200 MM



PIOGGIA•CASCATA•NEBULIZZATO
RAIN•WATERFALL•MIST SPRAY



SOFFITTO
CEILING



CROMO
CHROME

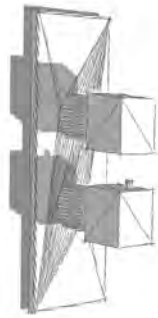
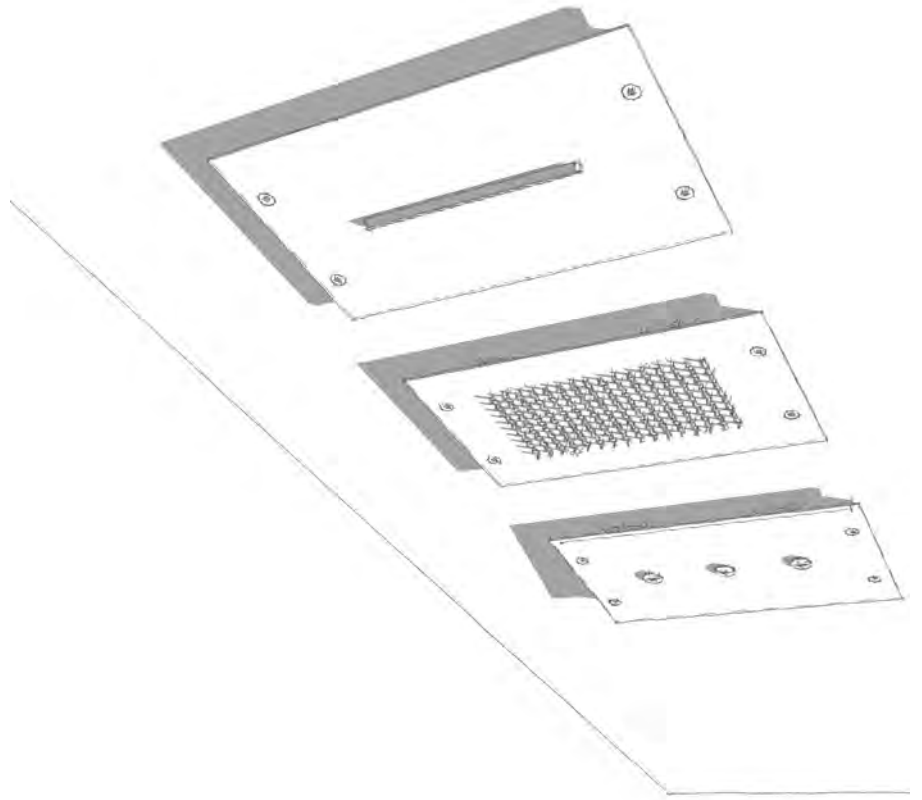

COMPOSIZIONE 5

COMPOSITIONS

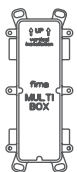

fimamultibox

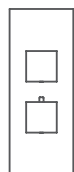
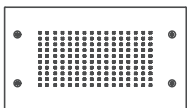

38

THERMOSTATIC

#SHOWERHEAD

SHOWERH

#PASSION



LEAD





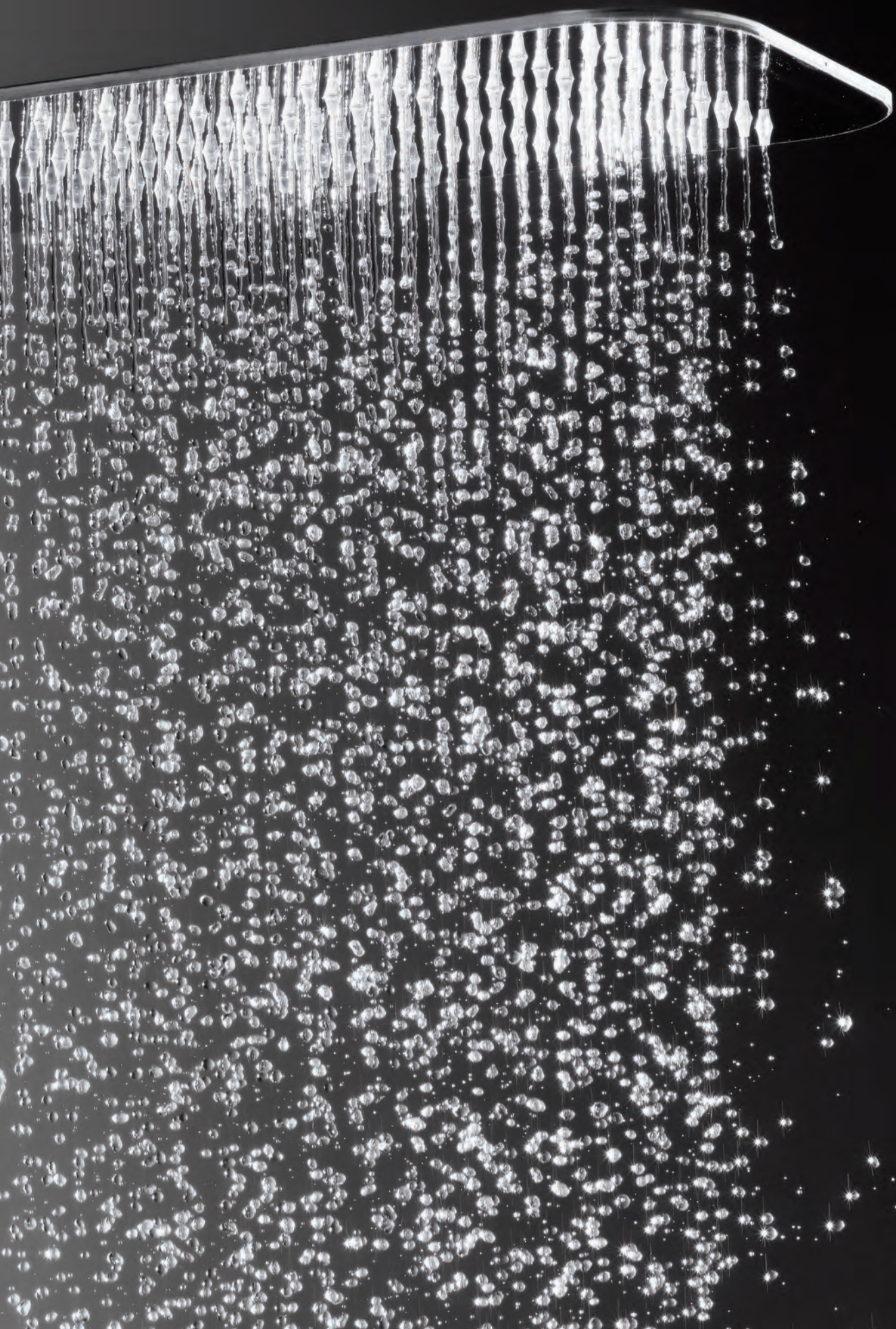

66



SPECIFICHE TECNICHE • TECHNICAL SPECIFICATIONS



ACCIAIO INOX
STAINLESS STEEL



15 L/MIN.



553x170 MM



PIOGGIA • CASCATA
RAIN • WATERFALL



PARETE
WALL



CROMO
CHROME

FUNZIONI DIFFERENTI NEL MINIMO SPESSORE

MULTIPLE FUNCTIONS IN A MINIMAL THICKNESS

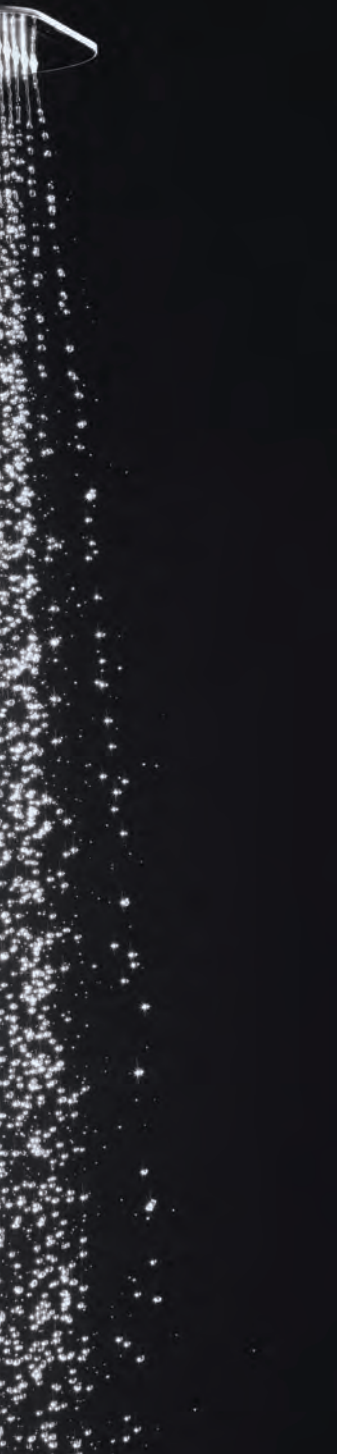

F2347



F2628



F2346

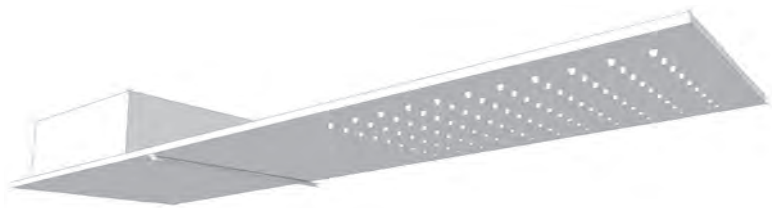

F2627



553 MM

170 MM



F2623



165 MM

250 MM



F2782

145 MM



300 MM



COMPOSIZIONE 6

COMPOSITIONS

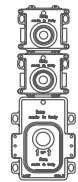
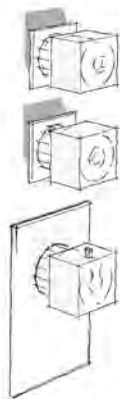
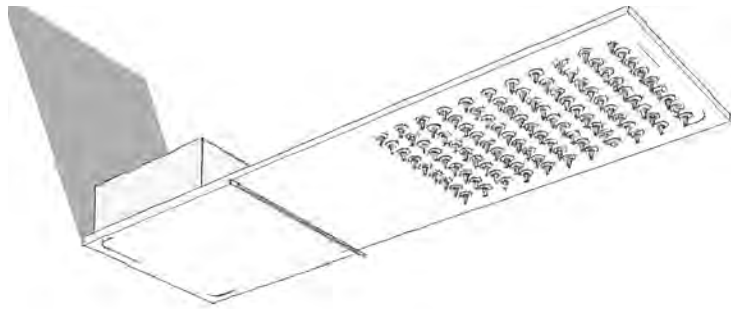

FIMATHERMBOX

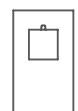
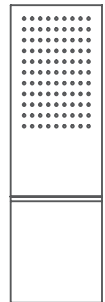

38

THERMOSTATIC

#SQUARE&ROUND

SQUARE
ROUND

#COLORS





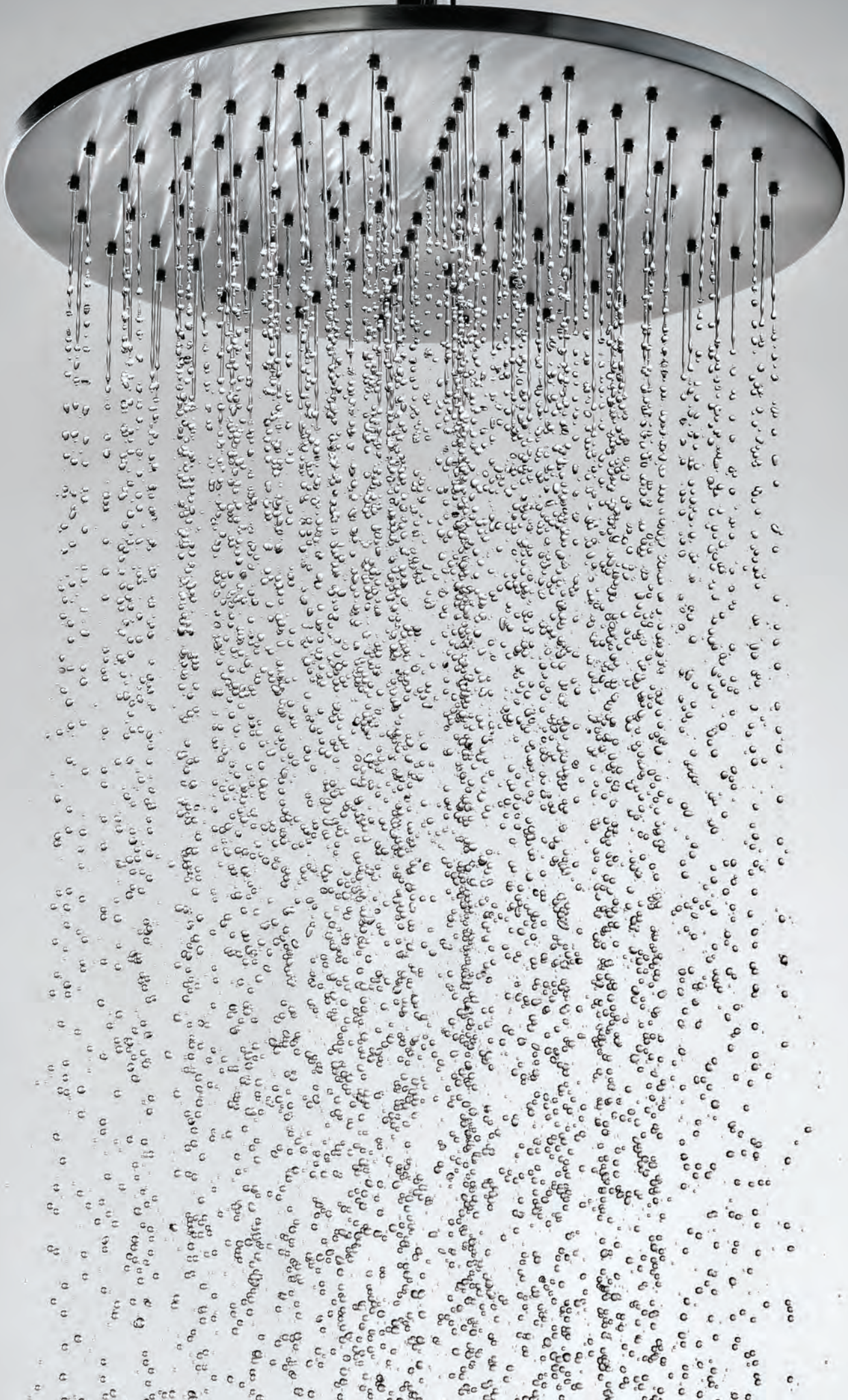

FORME E DIMENSIONI DIFFERENTI PER LA MASSIMA PERSONALIZZAZIONE

DIFFERENT SHAPES AND DIMENSIONS FOR MAXIMUM CUSTOMIZATION

ROUND

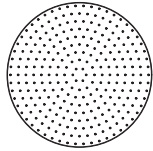

Ø 200

F2117/2
OTTONE·BRASS

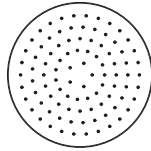

Ø 200

F2267/2
ABS

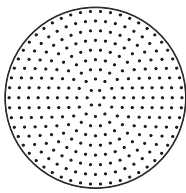

Ø 250

F2621/2
OTTONE·BRASS

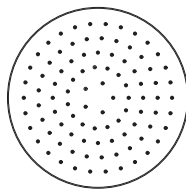

Ø 250

F2794/2
ABS

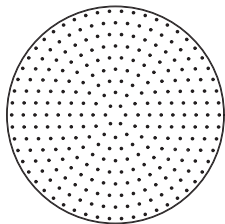

Ø 300

F2224/2
OTTONE·BRASS

CLASSIC

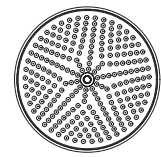

Ø 200

F2071/2
OTTONE·BRASS

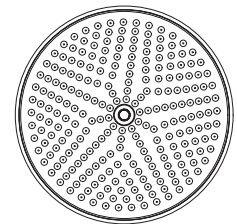

Ø 300

F2371/2
OTTONE·BRASS

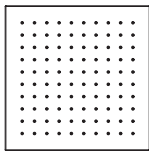

200x200

F2620/2
OTTONE·BRASS

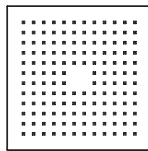

200x200

F2445/2
ABS

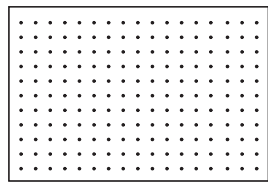

240x360

F2795/2
ABS

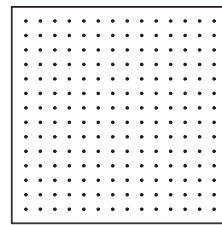

300x300

F2216/2
OTTONE·BRASS

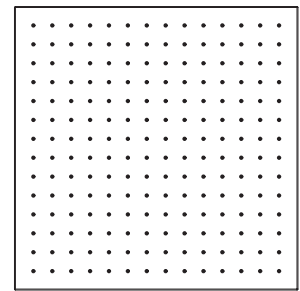

400x400

F2639/2
OTTONE·BRASS

SQUARE



CROMO
CHROME



NICKEL SPAZZOLATO
BRUSHED NICKEL



BIANCO
WHITE



NERO
BLACK



BRONZO
OLD BRONZE



ORO
GOLD



RAME ANTICO
OLD COPPER



RAME LUCIDO
SHINY COPPER

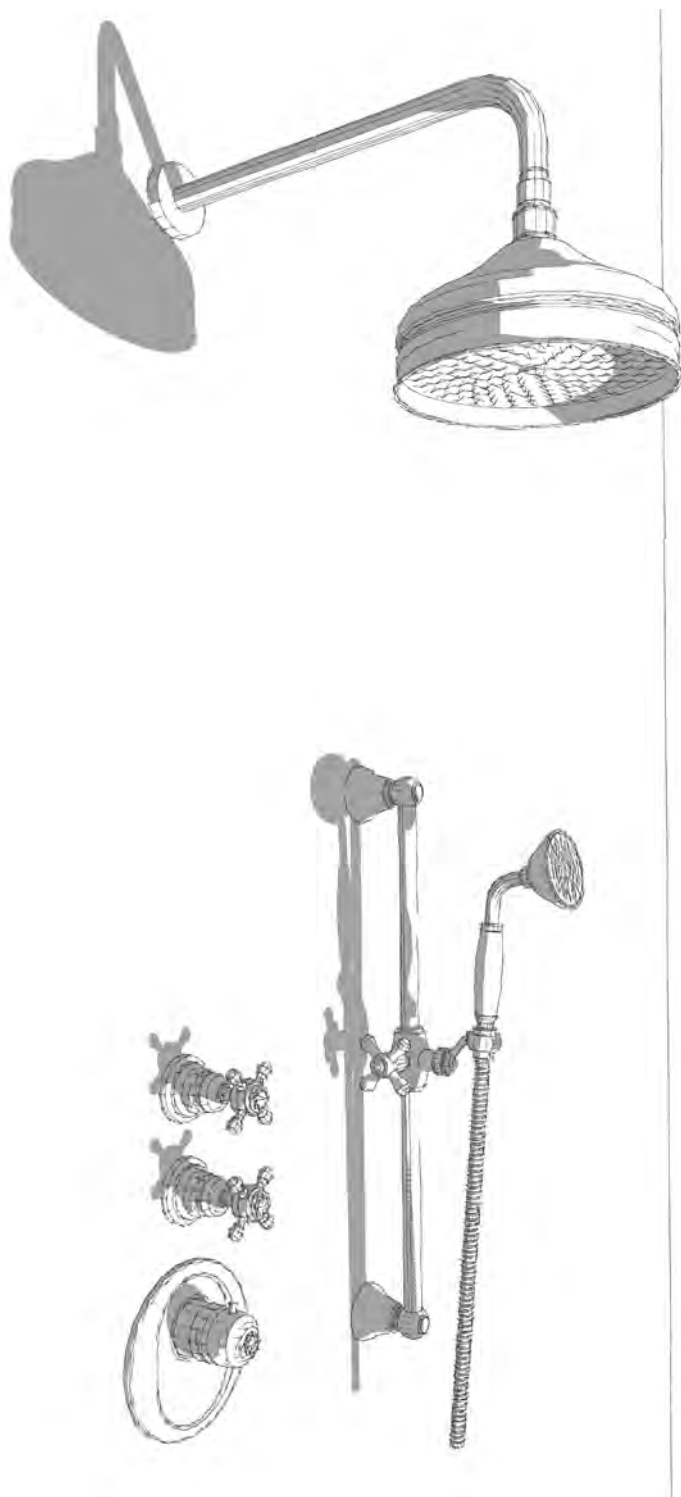

FIMATHERMBOX

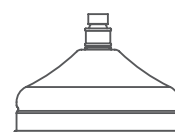

38

THERMOSTATIC

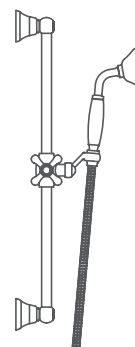

SPECIFICHE TECNICHE • TECHNICAL SPECIFICATIONS



OTTONE
BRASS



15 L/MIN.



200 MM
250MM
300MM
240x360MM



GETTO A PIOGGIA
RAIN FLOW



PARETE•SOFFITTO
WALL•CEILING



CROMO•CHROME
BIANCO•WHITE
NERO•BLACK
NICKEL SPAZZOLATO•BRUSHED NICKEL
BRONZO•BRONZE
ORO•GOLD
RAME ANTICO•OLD COPPER
RAME LUCIDO•SHINY COPPER



#FIMABOXES

IL CUORE DEL TUO AMBIENTE DOCCIA

THE HEARTH OF YOUR SHOWER SYSTEM



FIMATHERMBOX

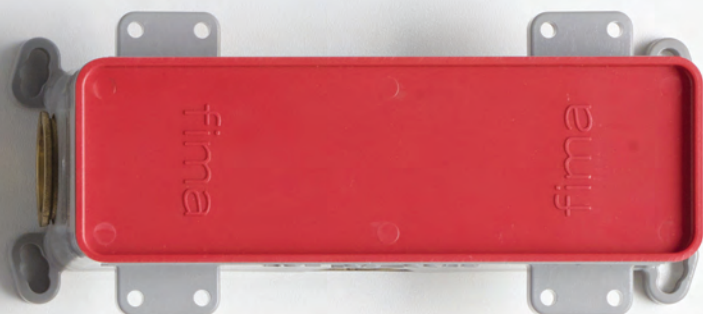

Fimatwin**box**



Fimamulti**box**



Fima**box**

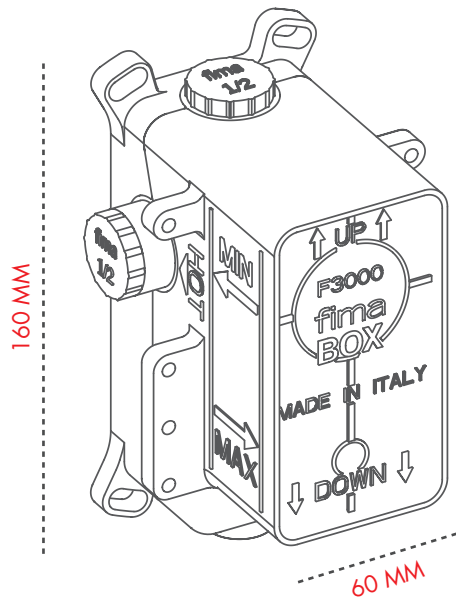

MECCANICO
MECHANICAL



TERMOSTATICO
THERMOSTATIC

COMPATIBILE CON PARTI ESTERNE SIA MECCANICHE CHE TERMOSTATICHE
COMPATIBLE TO EITHER EXTERNAL MECHANICAL OR THERMOSTATIC SHOWER MIXERS



1.2 USCITE
OUTLETS



UNIVERSALE PER TUTTE LE SERIE
UNIVERSAL FOR ALL COLLECTIONS

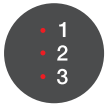

FACILE DA INSTALLARE
EASY INSTALLATION



CLASSE "A" PER RUMOROSITÀ
CLASS "A" FOR NOISE
UNI EN ISO 3822. < di 20dB max flow



NON TRASMETTE VIBRAZIONI
DOES NOT TRANSMIT VIBRATIONS



IMPERMEABILE
WATERPROOF



DEVIATORE PUSH & PULL
PUSH & PULL DIVERTER



OTTONE DZR
DZR BRASS

PROFONDITÀ INCASSO
LESS PROTRUSIVE INSTALLATION

60MM

TOLLERANZA DI INSTALLAZIONE
INSTALLATION DEPTH TOLERANCE

30MM

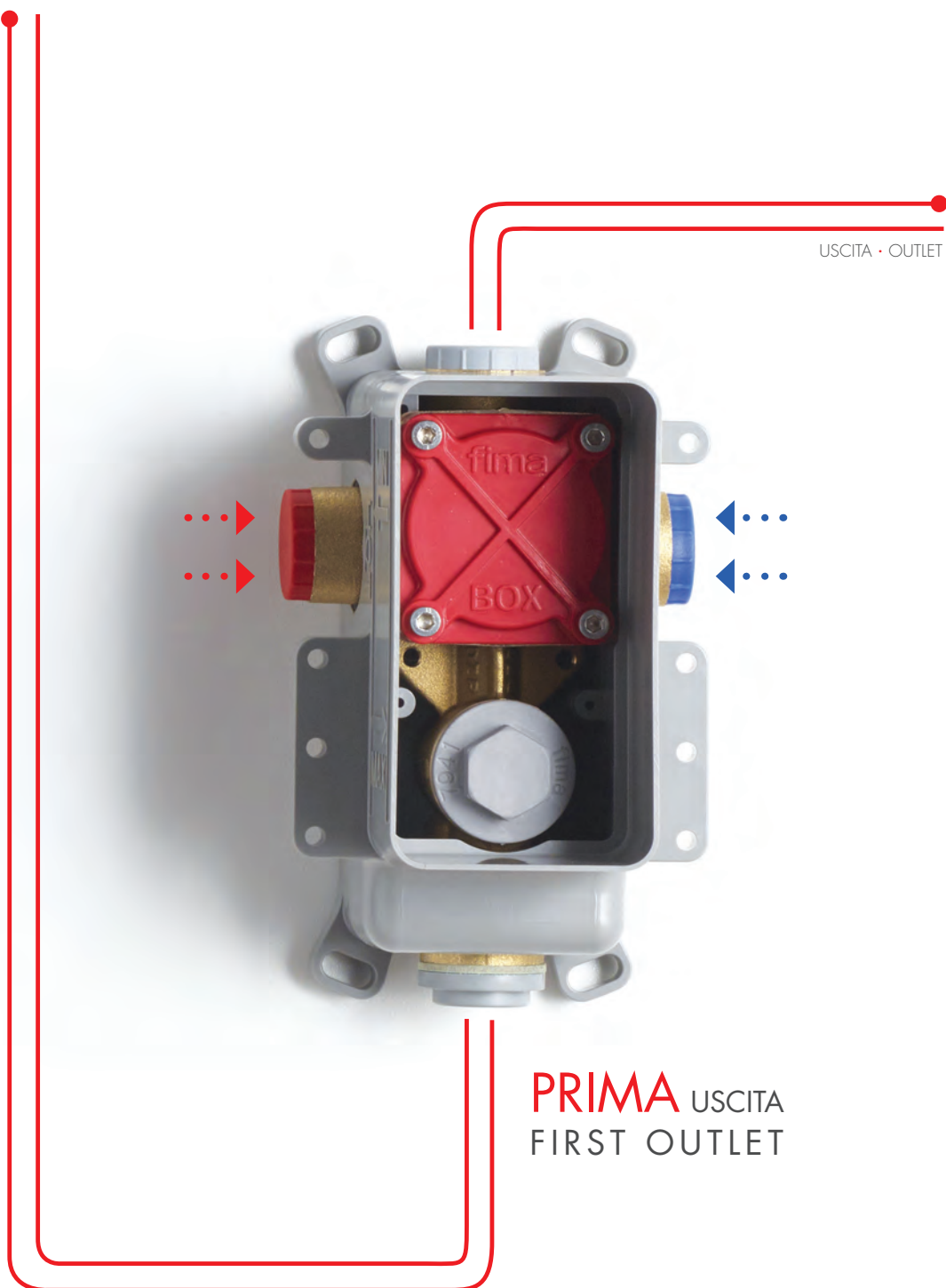

USCITA · OUTLET

PRIMA USCITA
FIRST OUTLET

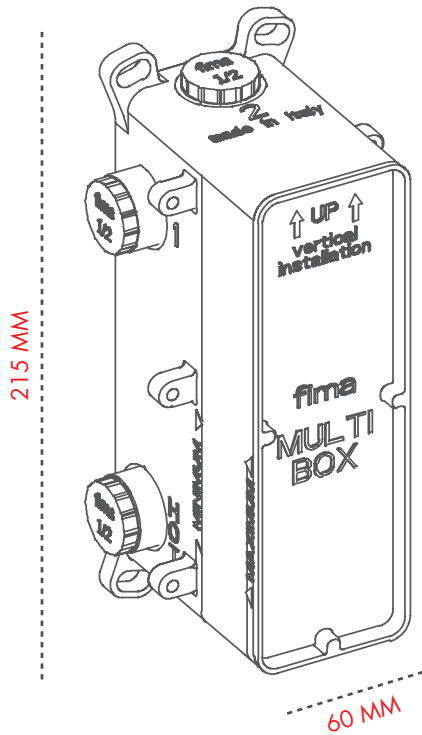

MECCANICO
MECHANICAL



TERMOSTATICO
THERMOSTATIC

COMPATIBILE CON PARTI ESTERNE SIA MECCANICHE CHE TERMOSTATICHE
COMPATIBLE TO EITHER EXTERNAL MECHANICAL OR THERMOSTATIC SHOWER MIXERS

SPECIFICHE TECNICHE • TECHNICAL SPECIFICATIONS



2-3 USCITE
OUTLETS



UNIVERSALE PER TUTTE LE SERIE
UNIVERSAL FOR ALL COLLECTIONS



FACILE DA INSTALLARE
EASY INSTALLATION



NON TRASMETTE VIBRAZIONI
DOES NOT TRANSMIT VIBRATIONS



IMPERMEABILE
WATERPROOF



OTTONE DZR
DZR BRASS

PROFONDITÀ INCASSO
LESS PROTRUSIVE INSTALLATION

60MM

TOLLERANZA DI INSTALLAZIONE
INSTALLATION DEPTH TOLERANCE

30MM

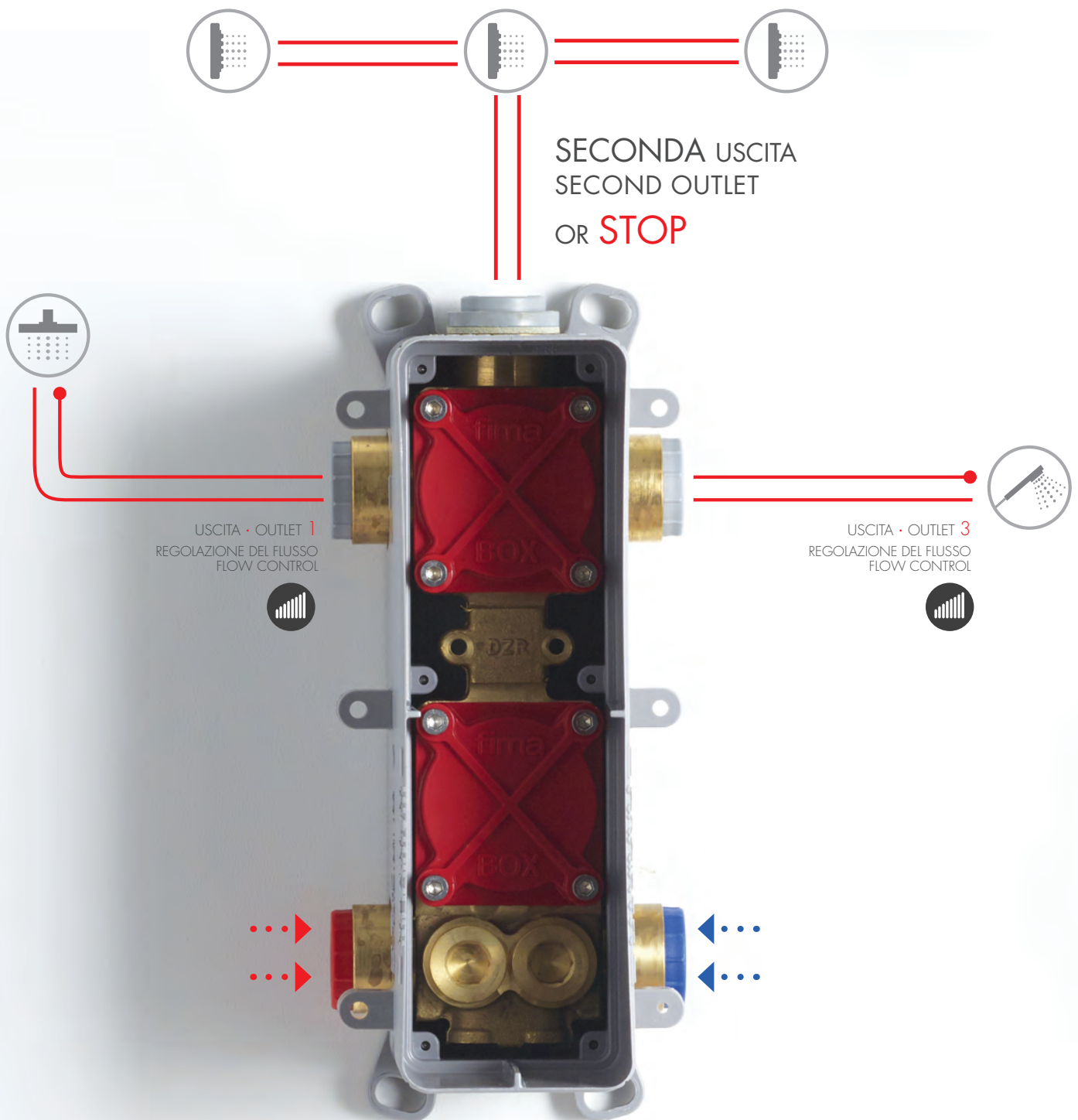

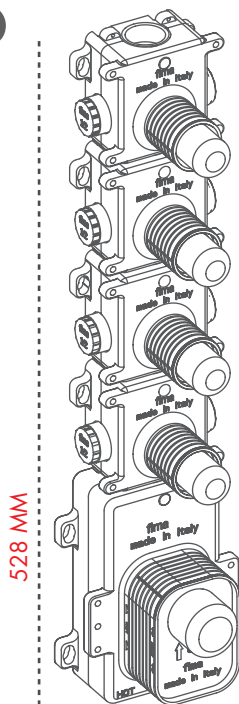

F2464

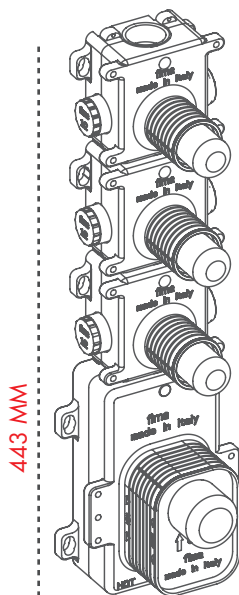

F2463

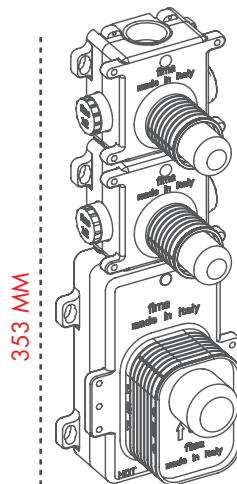

F2462

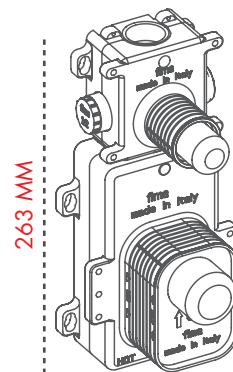

F2461



4 USCITE
OUTLETS

3 USCITE
OUTLETS

2 USCITE
OUTLETS

1 USCITA
OUTLET



UNIVERSALE PER TUTTE LE SERIE
UNIVERSAL FOR ALL COLLECTIONS



FACILE DA INSTALLARE
EASY INSTALLATION



NON TRASMETTE VIBRAZIONI
DOES NOT TRANSMIT VIBRATIONS



IMPERMEABILE
WATERPROOF



OTTONE DZR
DZR BRASS



INSTALLAZIONE ORIZZONTALE O VERTICALE
HORIZONTAL OR VERTICAL INSTALLATION



TUTTE LE USCITE CONTEMPORANEAMENTE
ALL OUTLETS SIMULTANEOUSLY



TERMOSTATICO
THERMOSTATIC



FINO A 50L.MIN.
UP TO 50L.MIN.

PROFONDITÀ INCASSO
LESS PROTRUSIVE INSTALLATION

60MM

TOLLERANZA DI INSTALLAZIONE
INSTALLATION DEPTH TOLERANCE

30MM



USCITA · OUTLET

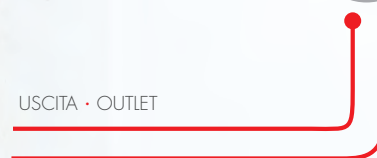

USCITA · OUTLET



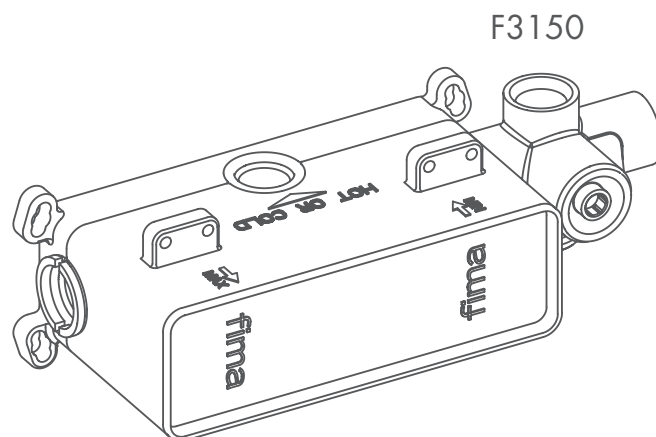
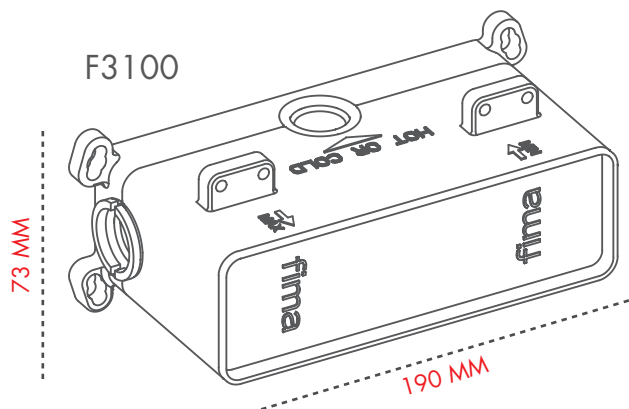

2·3 USCITE
OUTLETS



UNIVERSALE PER TUTTE LE SERIE
UNIVERSAL FOR ALL COLLECTIONS



FACILE DA INSTALLARE
EASY INSTALLATION



NON TRASMETTE VIBRAZIONI
DOES NOT TRANSMIT VIBRATIONS



IMPERMEABILE
WATERPROOF



OTTONE DZR
DZR BRASS



GESTIONE INDIPENDENTE DELLA TEMPERATURA
INDIPENDENT CONTROL OF TEMPERATURE



TUTTE LE USCITE CONTEMPORANEAMENTE
ALL OUTLETS SIMULTANEOUSLY



MECCANICO
MECHANICAL

PROFONDITÀ INCASSO
LESS PROTRUSIVE INSTALLATION

72MM

TOLLERANZA DI INSTALLAZIONE
INSTALLATION DEPTH TOLERANCE

30MM

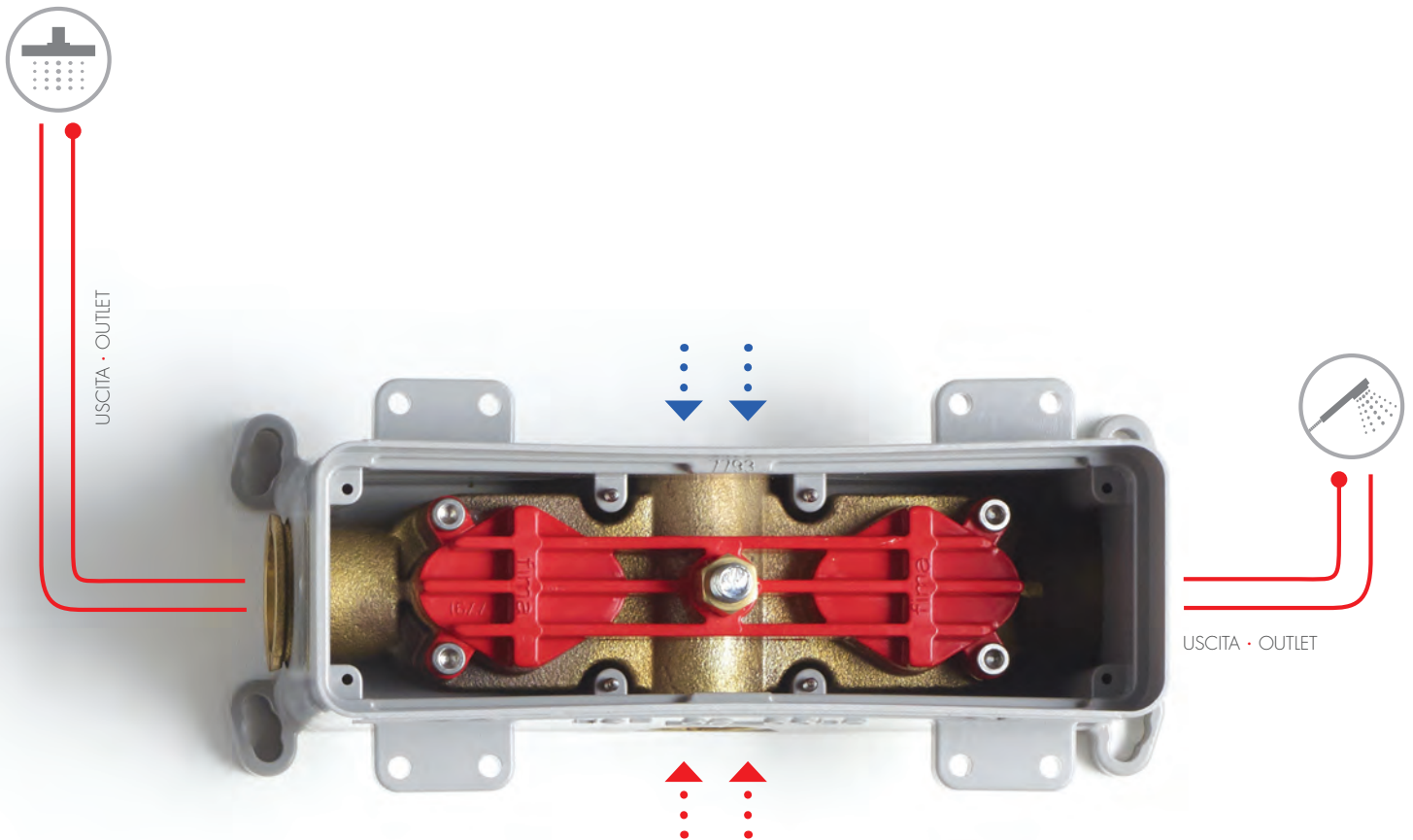

DOPPIO MISCELATORE CON GESTIONE
INDIPENDENTE DI FLUSSO E PORTATA
DOUBLE MIXER WITH INDEPENDENT CONTROL OF FLOW AND TEMPERATURE

#NU

COMPOSIZIONE DOCCIA • SHOWER COMPOSITION PAG. 12 • 13

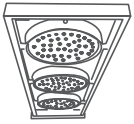

F2855CR

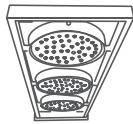

F2462



F3513X2CR

#CLOUD

COMPOSIZIONE DOCCIA • SHOWER COMPOSITION PAG. 20 • 21

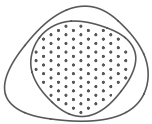

F2651BCR

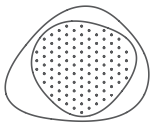

F2651NCR



F2461



F3253X1BS



F3253X1NS

#SFERA

COMPOSIZIONE DOCCIA • SHOWER COMPOSITION PAG. 28 • 29



F2340CRB



F2220



F3243/1BS



#HARMONIA

COMPOSIZIONE DOCCIA • SHOWER COMPOSITION PAG. 36 • 37

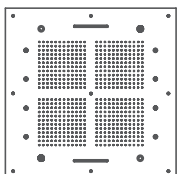

F2900CR



F2464



F5603X4HCR

#MODULAR

COMPOSIZIONE DOCCIA • SHOWER COMPOSITION PAG. 44 • 45



F2805CR

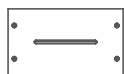

F2810CR



F2820CR



F2464



F5603X4VCR



F2287/4CR

#SHOWERHEAD

COMPOSIZIONE DOCCIA • SHOWER COMPOSITION PAG. 52 • 53

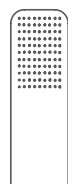

F2628CR

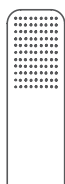

F3100



F3929X2CR

companies
G-EXPERIENCE (DIEGO MARIA GUGLIERMETTO)

graphic project
FIMA CARLO FRATTINI
photo
WALTER ZERLA

Fima Carlo Frattini S.p.A.
28010 - Briga Novarese (NO)
Via Borgomanero, 105
tel. +39 0322 9549 (r.a.)
fax. +39 0322 956149
e-mail: info@fimacl.com
www.fimacl.com

fima | CARLO FRATTINI®
r a b i n e t t e r i e